

'HOW TO MANAGE' SERIES FOR HEALTHCARE TECHNOLOGY

Guide 5

How to Organize the Maintenance of Your Healthcare Technology

*Management Procedures for
Health Facilities and District Authorities*



Dedicated to baby Nathan and Trevor, for their patience and help.

Published by TALC, PO Box 49, St. Albans, Hertfordshire, AL1 5TX, UK
Tel: +44 (0)1727 853869, fax: +44 (0)1727 846852, email: info@talcuk.org,
website: www.talcuk.org

Copyright © 2005 Ziken International

Ziken International (Consultants) Ltd,
Causeway House, 46 Malling Street, Lewes, East Sussex, BN7 2RH, UK
Tel: +44 (0)1273 477474, fax: +44 (0)1273 478466, email: info@ziken.co.uk,
website: www.ziken.co.uk

'How to Manage' Series for Healthcare Technology

Guide 1: How to Organize a System of Healthcare Technology Management

Guide 2: How to Plan and Budget for your Healthcare Technology

Guide 3: How to Procure and Commission your Healthcare Technology

Guide 4: How to Operate your Healthcare Technology Effectively and Safely

Guide 5: How to Organize the Maintenance of your Healthcare Technology

Guide 6: How to Manage the Finances of your Healthcare Technology
Management Teams

Keywords: *healthcare technology, management procedures, health service administration, district health services, developing countries, maintenance, workshop management, equipment*

Any parts of this publication, including the illustrations, may be copied, reproduced, or adapted to meet local needs, without permission, provided that the parts reproduced are distributed free or at cost – not for profit. For any reproduction with commercial ends, permission must first be obtained from the publisher. The publisher would appreciate being sent a copy of materials in which text or illustrations have been used.

This document is an output from a project funded by the UK government's Department for International Development (DFID) for the benefit of developing countries. The views expressed are not necessarily those of DFID.

ISBN: 0-9549467-4-X

All rights reserved

A catalogue record is available from the British Library

Design and layout by Jules Stock (email: julesstock@macunlimited.net)

Illustrations and charts by David Woodroffe (email: davedraw@dircon.co.uk)

Edited by Sarah Townsend Editorial (email: sarah@sarahtownsendeditorial.co.uk,
website: www.sarahtownsendeditorial.co.uk)

‘How to Manage’ Series for Healthcare Technology

Guide 5

How to Organize the Maintenance of Your Healthcare Technology

by:

Caroline Temple-Bird

Healthcare Technology Management Consultant,
Ziken International Consultants Ltd, Lewes, UK

Manjit Kaur

Development Officer, ECHO International Health Services, Coulsdon, UK

Andreas Lenel

Health Economist Consultant, FAKT, Stuttgart, Germany

Willi Kawohl

Financial Management Consultant, FAKT, Stuttgart, Germany

Series Editor

Caroline Temple-Bird

Healthcare Technology Management Consultant,
Ziken International Consultants Ltd, Lewes, UK

CONTENTS

Section	Page
Foreword	i
Preface	i
Acknowledgements	iii
Abbreviations	v
List of Boxes and Figures	vii
1. Introduction	1
1.1 Introduction to the Series of Guides	1
1.2 Introduction to this Specific Guide	9
2. Framework Requirements	17
2.1 Framework Requirements for Quality Health Services	18
2.2 Background Conditions Specific to this Guide	27
3. How To Plan Maintenance Work	35
3.1 Priority Setting and Work Allocation	35
3.2 Repairs/Corrective Maintenance	42
3.3 Planned Preventive Maintenance	48
3.4 Safety and Calibration Testing	54
3.5 Site and Contract Management	59
3.6 Managing Outreach Work	65
4. How To Keep a Record of Maintenance Work	71
4.1 Overview	71
4.2 Fault Reporting and Monitoring Completion	77
4.3 Monitoring Team Progress and Recording Work Undertaken	83
4.4 Service History Files	88
5. How To Manage Tools and Work Facilities	95
5.1 Tools Requirements	95
5.2 Security and a Storage System for Tools	97
5.3 Managing the Work Space	102

6. How To Ensure Availability of Spare Parts and Maintenance Materials	107
6.1 General Discussion on Spare Parts and Maintenance Materials	107
6.2 Storage System and Procedures	113
6.3 Calculating Usage Rates and Reorder Levels	120
7. How To Manage Staff	135
7.1 Creating Multi-Disciplinary Teams	135
7.2 Reporting and Feedback	138
7.3 Evaluation of Staff and Ongoing Appraisals	143
7.4 Skills Development	146
8. How To Undertake Action Planning and Monitoring of Progress	155
8.1 Setting Goals (Annually)for Equipment Maintenance	157
8.2 Monitoring Progress with Equipment Maintenance	164
Annexes	171
1. Glossary	171
2. Reference Materials and Contacts	176
3. Skill Levels for Different Maintenance Tasks	206
4. The Role of Equipment Users in Maintenance	208
5. General Maintenance Register	211
6. Tools Lists	212
7. Workshop Layouts	220
8. Entering Items Into the Stock Control System	223
9. Example of a Supplies Order Form	225
10. Source Material/Bibliography	226

Foreword

This Series of Guides is the output from a project funded by the UK government's Department for International Development (DFID) for the benefit of developing countries. The output is the result of an international collaboration that brought together:

- ◆ researchers from Ziken International and ECHO International Health Services in the UK, and FAKT in Germany
- ◆ an advisory group from WHO, PAHO, GTZ, the Swiss Tropical Institute, and the Medical Research Council of South Africa
- ◆ reviewers from many countries in the developing world

in order to identify best practice in the field of healthcare technology management.

The views expressed are not necessarily those of DFID or the other organizations involved.

Garth Singleton

Manager, Ziken International Consultants Ltd, Lewes, UK

Preface

The provision of equitable, quality and efficient healthcare requires an extraordinary array of properly balanced and managed resource inputs. Physical resources such as fixed assets and consumables, often described as healthcare technology, are among the principal types of those inputs. Technology is the platform on which the delivery of healthcare rests, and the basis for provision of all health interventions. Technology generation, acquisition and utilization require massive investment, and related decisions must be made carefully to ensure the best match between the supply of technology and health system needs, the appropriate balance between capital and recurrent costs, and the capacity to manage technology throughout its life.

Healthcare technology has become an increasingly visible policy issue, and healthcare technology management (HTM) strategies have repeatedly come under the spotlight in recent years. While the need for improved HTM practice has long been recognized and addressed at numerous international forums, health facilities in many countries are still burdened with many problems, including non-functioning medical equipment as a result of factors such as inadequate planning, inappropriate procurement, poorly organized and managed healthcare technical services, and a shortage of skilled personnel. The situation is similar for other health system physical assets such as buildings, plant and machinery, furniture and fixtures, communication and information systems, catering and laundry equipment, waste disposal, and vehicles.

Preface (continued)

The (mis-)management of physical assets impacts on the quality, efficiency and sustainability of health services at all levels, be it in a tertiary hospital setting with sophisticated life-support equipment, or at the primary healthcare level where simple equipment is needed for effective diagnosis and safe treatment of patients. What is vital – at all levels and at all times – is a critical mass of affordable, appropriate, and properly functioning equipment used and applied correctly by competent personnel, with minimal risk to their patients and to themselves. Clear policy, technical guidance, and practical tools are needed for effective and efficient management of healthcare technology for it to impact on priority health problems and the health system's capacity to adequately respond to health needs and expectations.

This Series of Guides aims to promote better management of healthcare technology and to provide practical advice on all aspects of its acquisition and utilization, as well as on the organization and financing of healthcare technical services that can deliver effective HTM.

The Guides – individually and collectively – have been written in a way that makes them generally applicable, at all levels of health service delivery, for all types of healthcare provider organizations and encompassing the roles of health workers and all relevant support personnel.

It is hoped that these Guides will be widely used in collaboration with all appropriate stakeholders and as part of broader HTM capacity-building initiatives being developed, promoted and implemented by WHO and its partners, and will therefore contribute to the growing body of evidence-based HTM best practice.

The sponsors, authors and reviewers of this Series of Guides are to be congratulated for what is a comprehensive and timely addition to the global HTM toolkit.

Andrei Issakov, Coordinator, Health Technology and Facilities Planning and Management, World Health Organization, Geneva, Switzerland

Mladen Poluta, Director, UCT/WHO HTM Programme, University of Cape Town, South Africa

Acknowledgements

This Guide was written:

◆ **with specialist support from:**

Trond Fagerli, Senior Advisor, Haraldsplass Deaconal Hospital, Bergen, Norway
(former Chief Biomedical Engineer, Ministry of Health, Botswana)

◆ **with assistance from an Advisory Group of:**

Hans Halbwachs, Healthcare Technology Management, Deutsche Gesellschaft für Technische Zusammenarbeit (GTZ-GmbH), Eschborn, Germany

Peter Heimann, Director, WHO Collaborating Centre for Essential Health Technologies, Medical Research Council of South Africa, Tygerberg, South Africa

Antonio Hernandez, Regional Advisor, Health Services Engineering and Maintenance, PAHO/WHO, Washington DC, USA

Andrei Issakov, Coordinator, Health Technology and Facilities Planning and Management, Department of Health System Policies and Operations, WHO, Geneva, Switzerland

Yunkap Kwankam, Scientist, Department of Health Service Provision, WHO, Geneva, Switzerland

Martin Raab, Biomedical Engineer, Swiss Centre for International Health of the Swiss Tropical Institute, Basle, Switzerland

Gerald Verollet, Technical Officer, Medical Devices, Blood Safety and Clinical Technology (BCT) Department, WHO, Geneva, Switzerland

Reinhold Werlein, Biomedical Engineer, Swiss Centre for International Health of the Swiss Tropical Institute, Basle, Switzerland

◆ **and reviewed by:**

Dr P Asman, Head of the Bio-Engineering Unit, Ministry of Health, Accra, Ghana

Tsibu J Bbuku, Medical Equipment Specialist, Central Board of Health, Lusaka, Zambia

Juliette Cook, Biomedical Engineer, Advisor to Ministries of Health of Mozambique, and Vanuatu

Peter Cook, Biomedical Engineer, ECHO International Health Services, Coulsdon, UK

Freedom Dellosa, Chief of Hospital Equipment Maintenance Service Division, Region 9 – Mindanao Peninsula, Department of Health, Zambonga City, Philippines

Pieter de Ruijter, HTM Consultant, HEART Consultancy, Renkum, The Netherlands

Roland Fritz, HCTS Coordinator, Christian Social Services Commission,
Dar es Salaam, Tanzania

Andrew Gammie, Project Director, International Nepal Fellowship, Pokhara, Nepal

Aly Khan Husein, Engineering and Transport Manager, Aga Khan Foundation Private
Hospital, Nairobi, Kenya

Elias Luhana, Head of Biomedical Engineering, University Teaching Hospital,
Lusaka, Zambia

Andrew McDowell, Biomedical Engineer, ECHO International Health Services,
Coulsdon, UK

Yohana Mkwizu, Regional Health Care Technical Service Coordinator,
GTZ District Health Support Project, Tanga Region, Tanzania

Ghanshyam Pandey, Biomedical Consultant, Medical Technology Pvt. Ltd,
Kathmandu, Nepal

Sulaiman Shahabuddin, Director, Patient Services, Aga Khan Foundation
Private Hospital, Nairobi, Kenya

Sol Sowath, Provincial MCH Coordinator and former Technical Bureau Chief,
Provincial Health Department, Kampot, Cambodia

Birgit Thiede, Physical Assets Management (PAM) Advisor, Ministry of Health,
Phnom Penh, Cambodia

John Zienaa, Ashanti Regional Equipment Manager, Ministry of Health, Kumasi, Ghana

◆ **using source material:**

as described in *Annex 10: Source Material/Bibliography*

◆ **with financial assistance from:**

the Knowledge and Research Programme on Disability and Healthcare Technology,
DFID, government of the United Kingdom

◆ **with administrative support from:**

all the staff at Ziken International Consultants Ltd, UK, especially Garth Singleton,
Rob Parsons, and Lou Korda, as well as Thomas Rebohle from FAKT, Germany

Abbreviations

AHA	American Hospital Association
AMC	average monthly consumption
Amps	Amperes
BP	blood pressure
CD-Rom	compact disc – read only memory
CSSD	central sterile supplies department
CT	computed tomography (scanner)
DB	distribution board
DVD	digital versatile disc
ECG	electrocardiograph
FIFO	first in, first out
g	grams
GTZ	Deutsche Gesellschaft für Technische Zusammenarbeit (German government technical aid agency)
HTM	healthcare technology management
HTMS	healthcare technology management service
HTMWG	healthcare technology management working group
Hz	Hertz
ICU	intensive care unit
IEC	International Electrotechnical Commission
IEE	Institution of Electrical Engineers
ISO	International Organization for Standardization
LT	lead time
Max.	maximum level
MES	medical electrical safety (tester)
Min.	minimum level
MOH	Ministry of Health
NGO	non-governmental organization
OPD	out-patients department
OQ	order quantity
PAT	portable appliance tester
PPM	planned preventive maintenance
RF	reduction factor
RS	reserve stock
SMART	specific, measurable, achievable, relevant, time-bound (targets)

SLFO	shortest life, first out
TBO	time between orders
UPS	uninterruptible power supply
US\$	United States dollars
V	Volts
VDU	visual display unit
VEN (VED)	vital, essential, not so essential/desirable (prioritizing categories)
WHO	World Health Organization

List of Boxes and Figures

		Page
Box 1	Categories of items described as ‘healthcare technology’	2
Box 2	Benefits of healthcare technology management (HTM)	4
Box 3	The collective responsibility for maintenance	14
Box 4	Summary of issues in <i>Section 2</i> on framework requirements	33
Box 5	The VEN (or VED) system for prioritizing maintenance	37
Box 6	Example strategy for spreading responsibility for maintenance among the health team	41
Box 7	Strategies for sourcing useful literature and advice, and expanding your library	46
Box 8	Example of maintainer PPM instructions for infant incubators	51
Box 9	Example of maintainer PPM instructions for electrode boilers	52
Box 10	Example of maintainer PPM instructions for plumbing installations when starting out	52
Box 11	Strategies for developing PPM schedules	53
Box 12	Example of safety and calibration testing instruments by type of work and skill level	58
Box 13	Potential external sources of maintenance support	60
Box 14	Types of arrangements for external parties to provide maintenance services	63
Box 15	Summary of procedures in <i>Section 3</i> on work planning	67
Box 16	Data to store for each piece of equipment	73
Box 17	Summary of registers, ledgers, and files used for maintenance, and who keeps them	75
Box 18	Summary of procedures in <i>Section 4</i> on a maintenance record system	92
Box 19	Advantages and disadvantages of tool ownership	97
Box 20	Possible security strategies to consider for tools	98
Box 21	Various initiatives for storing tools	100
Box 22	Summary of procedures in <i>Section 5</i> on managing tools and work facilities	105
Box 23	Strategies for storing equipment-related items	115
Box 24	Strategies for creating suitable store rooms	117
Box 25	Steps for calculating annual requirements of spare parts and maintenance materials	122

Box 26	How to calculate how many parts should be stocked where	127
Box 27	How to calculate reordering times and quantities	130
Box 28	Summary of procedures in <i>Section 6</i> on spare parts and maintenance materials	133
Box 29	Basic training requirements	136
Box 30	Typical contents for HTM status reports	142
Box 31	Strategies for staff appraisal meetings	144
Box 32	Strategies for developing equipment skills	148
Box 33	Resources required when running training courses yourselves	150
Box 34	Summary of procedures in <i>Section 7</i> on staff management	153
Box 35	Example of how to measure a goal	160
Box 36	Strategies for running an annual action planning seminar in the health service	163
Box 37	Examples of statistics which can be gathered regularly	167
Box 38	Summary of procedures in <i>Section 8</i> on action planning and reviewing progress	170
Box 39	WHO's definition of technology management hierarchy (<i>Annex 1</i>)	175
Box 40	Skills levels required according to maintenance needs (<i>Annex 3</i>)	206
Box 41	Common care and cleaning strategies for users (<i>Annex 4</i>)	208
Box 42	Typical examples of the user's role in the PPM of equipment (<i>Annex 4</i>)	209
Box 43	Example of user PPM instructions for infant incubators (<i>Annex 4</i>)	210
Box 44	Example of user PPM instructions for electrode boilers (<i>Annex 4</i>)	210
Figure 1	The place of healthcare technology management in the health system	1
Figure 2	The relationship between the Guides in this Series	6
Figure 3	Potential and life of equipment with and without maintenance	10
Figure 4	The structure of <i>Guide 5</i>	12
Figure 5	The healthcare technology management cycle	20
Figure 6	Sample organizational chart for the HTM service	25
Figure 7	Good practice checklist for maintenance staff when fault-finding	44
Figure 8	Strategies for expanding PPM coverage by maintainers over time	49
Figure 9	Example timetable of PPM for maintainers in wall calendar format	54
Figure 10	Strategies for safety and calibration testing	59

Figure 11	Issues to consider when computerizing records	76
Figure 12	Example of a work request/job form	78
Figure 13A	Slotted board format	84
Figure 13B	How to use the visual display board shown in <i>Figure 13A</i>	85
Figure 14	Good practice checklist for maintenance staff when undertaking jobs	87
Figure 15	Summary of the use of the work request/job form	91
Figure 16	Suggested format for the tools issue register	101
Figure 17	Typical layout for a workshop of a 100-bed hospital	103
Figure 18	Example of the problems of a poorly laid out workshop	104
Figure 19	Sample stock card (bin card)	119
Figure 20	Sample layouts for the stock control ledger	132
Figure 21	Strategies for HTM Teams to provide feedback to users	140
Figure 22	Example of prompts showing that training is required	147
Figure 23	Strategies for developing training materials	151
Figure 24	The planning and review cycle	155
Figure 25	Types of forms which can be used for gathering and presenting statistics for a set time period	168
Figure 26	Division of maintenance work by skill level in the health service (<i>Annex 3</i>)	207
Figure 27	Sample general maintenance register layout (<i>Annex 5</i>)	211
Figure 28	Typical layout for a workshop of a 50-bed hospital (<i>Annex 7</i>)	220
Figure 29	Typical layout for a district workshop (<i>Annex 7</i>)	221
Figure 30	Layout of a zonal workshop covering an association of health service providers (<i>Annex 7</i>)	222
Figure 31	Example of a register of new stocks form (<i>Annex 8</i>)	224
Figure 32	Sample store requisition and issue voucher (<i>Annex 9</i>)	225

1. INTRODUCTION

Why is This Important?

This introduction explains the importance of healthcare technology management (HTM) and its place in the health system.

It also describes:

- ◆ the purpose of the Series of Guides and this Guide in particular
- ◆ the people the Guides are aimed at
- ◆ the names and labels commonly used in HTM, in this Series.

The Series of Guides is introduced in *Section 1.1*, and this particular Guide on organizing maintenance is introduced in *Section 1.2*.

1.1 INTRODUCTION TO THE SERIES OF GUIDES

Healthcare Technology Management's Place in the Health System

All health service providers want to get the most out of their investments. To enable them to do so, they need to actively manage health service assets, ensuring that they are used efficiently and optimally. All management takes place in the context of your health system's policies and finances. If these are favourable, the management of health service assets can be effective and efficient, and this will lead to improvements in the quality and quantity of healthcare delivered, without an increase in costs.

The health service's most valuable assets which must be managed are its human resources, physical assets, and other resources such as supplies. Physical assets such as facilities and healthcare technology are the greatest capital expenditure in any health sector. Thus it makes financial sense to manage these valuable resources, and to ensure that healthcare technology:

- ◆ is selected appropriately
- ◆ is used correctly and to maximum capacity
- ◆ lasts as long as possible.

Such effective and appropriate management of healthcare technology will contribute to improved efficiency within the health sector. This will result in improved and increased health outcomes, and a more sustainable health service. This is the goal of healthcare technology management – the subject of this Series of Guides.

Figure 1: The Place of Healthcare Technology Management in the Health System



What Do We Mean by Healthcare Technology?

The World Health Organization (WHO) uses the broader term ‘health technology’, which it defines as including:

‘devices, drugs, medical and surgical procedures – and the knowledge associated with these – used in the prevention, diagnosis and treatment of disease as well as in rehabilitation, and the organizational and supportive systems within which care is provided.’

(Source: Kwankam, Y, et al, 2001, ‘Health care technology policy framework’, WHO Regional Publications, Eastern Mediterranean Series 24: Health care technology management, No. 1)

However, the phrase ‘healthcare technology’ used in this Series of Guides only refers to the physical pieces of hardware in the WHO definition, that need to be maintained. Drugs and pharmaceuticals are usually covered by separate policy initiatives, frameworks, and colleagues in another department.

Therefore, we use the term healthcare technology to refer to the various equipment and technologies found within health facilities, as shown in *Box 1*.

BOX 1: Categories of Equipment and Technologies Described as ‘Healthcare Technology’

medical equipment	walking aids	health facility furniture
communications equipment	training equipment	office equipment
office furniture	fixtures built into the building	plant for cooling, heating, etc
service supply installations	equipment-specific supplies	fire-fighting equipment
workshop equipment	fabric of the building	vehicles
laundry and kitchen equipment	waste treatment plant	energy sources

For examples of these different categories, see the Glossary in *Annex 1*.

Often, different types of equipment and technologies are the responsibility of different organizations. For example, in the government sector, different ministries may be involved, such as Health, Works, and Supplies; and in the non-government sector, different agencies may be involved, such as Health, and Logistics.

The range of healthcare technology which falls under the responsibility of the health service provider varies from country to country and organization to organization. Therefore each country's definition of healthcare technology will vary depending on the range of equipment and technology types that they actually manage.

For simplicity, we often use the term 'equipment' in place of the longer phrase 'healthcare technology' throughout this Series of Guides.

What is Healthcare Technology Management?

First of all, healthcare technology management (HTM) involves the organization and coordination of all of the following activities, which ensure the successful management of physical pieces of hardware:

- ◆ Gathering reliable information about your equipment.
- ◆ Planning your technology needs and allocating sufficient funds for them.
- ◆ Purchasing suitable models and installing them effectively.
- ◆ Providing sufficient resources for their use.
- ◆ Operating them effectively and safely.
- ◆ Maintaining and repairing the equipment.
- ◆ Decommissioning, disposing of, and replacing unsafe and obsolete items.
- ◆ Ensuring staff have the right skills to get the best use out of your equipment.

This will require you to have broad skills in the management of a number of areas, including:

- ◆ technical problems
- ◆ finances
- ◆ purchasing procedures
- ◆ stores supply and control
- ◆ workshops
- ◆ staff development.

However, you also need skills to manage the place of healthcare technology in the health system. Therefore, HTM means managing how healthcare technology should interact and balance with your:

- ◆ medical and surgical procedures
- ◆ support services
- ◆ consumable supplies, and
- ◆ facilities

so that the complex whole enables you to provide the health services required.

Thus HTM is a field that requires the involvement of staff from many disciplines – technical, clinical, financial, administrative, etc. It is not just the job of managers, it is the responsibility of all members of staff who deal with healthcare technology.

This Series of Guides provides advice on a wide range of management procedures, which you can use as tools to help you in your daily work. For further clarification of the range of activities involved in HTM and common terms used, refer to the WHO's definition of the technology management hierarchy in *Annex 1*.

Box 2 highlights some of the benefits of HTM.

BOX 2: Benefits of Healthcare Technology Management (HTM)

- ◆ Health facilities can deliver a full service, unimpeded by non-functioning healthcare technology.
- ◆ Equipment is properly utilized, maintained, and safeguarded.
- ◆ Staff make maximum use of equipment, by following written procedures and good practice.
- ◆ Health service providers are given comprehensive, timely, and reliable information on:
 - the functional status of the equipment
 - the performance of the maintenance services
 - the operational skills and practice of equipment-user departments
 - the skills and practice of staff responsible for various equipment-related activities in a range of departments including finance, purchasing, stores, and human resources.
- ◆ Staff control the huge financial investment in equipment, and this can lead to a more effective and efficient healthcare service.

Purpose of the Series of Guides

The titles in this Series are designed to contribute to improved healthcare technology management in the health sectors of developing countries, although they may also be relevant to emerging economies, and other types of country. The Series is designed for any health sector, whether it is run by:

- ◆ government (such as the Ministry of Health or Defence)
- ◆ a non-governmental organization (NGO) (such as a charitable or not-for-profit agency)
- ◆ a faith organization (such as a mission)
- ◆ a corporation (for example, an employer such as a mine, who may subsidize the healthcare)
- ◆ a private company (such as a health insurance company or for-profit agency).

This Series aims to improve healthcare technology at a daily operational level, as well as to provide practical resource materials for equipment users, maintainers, health service managers, and external support agencies.

To manage your technology effectively, you will need suitable and effective procedures in place for all activities which impact on the technology. Your health service provider organization should already have developed a Policy Document setting out the principles for managing your stock of healthcare technology (*Annex 2* provides a number of resources available to help with this). The next step is to develop written organizational procedures, in line with the strategies laid out in the policy, which staff will follow on a daily basis.

The titles in this Series provide a straightforward and practical approach to healthcare technology management procedures:

Guide 1 covers the framework in which Healthcare Technology Management (HTM) can take place. It also provides information on how to organize a network of HTM Teams throughout your health service provider organization.

Guides 2 to 5 are resource materials which will help health staff with the daily management of healthcare technology. They cover the chain of activities involved in managing healthcare technology – from planning and budgeting to procurement, daily operation and safety, and maintenance management.

Guide 6 looks at how to ensure your HTM Teams carry out their work in an economical way, by giving advice on financial management.

How the Guides are coordinated is set out in *Figure 2*.

Figure 2: The Relationship Between the Guides in This Series

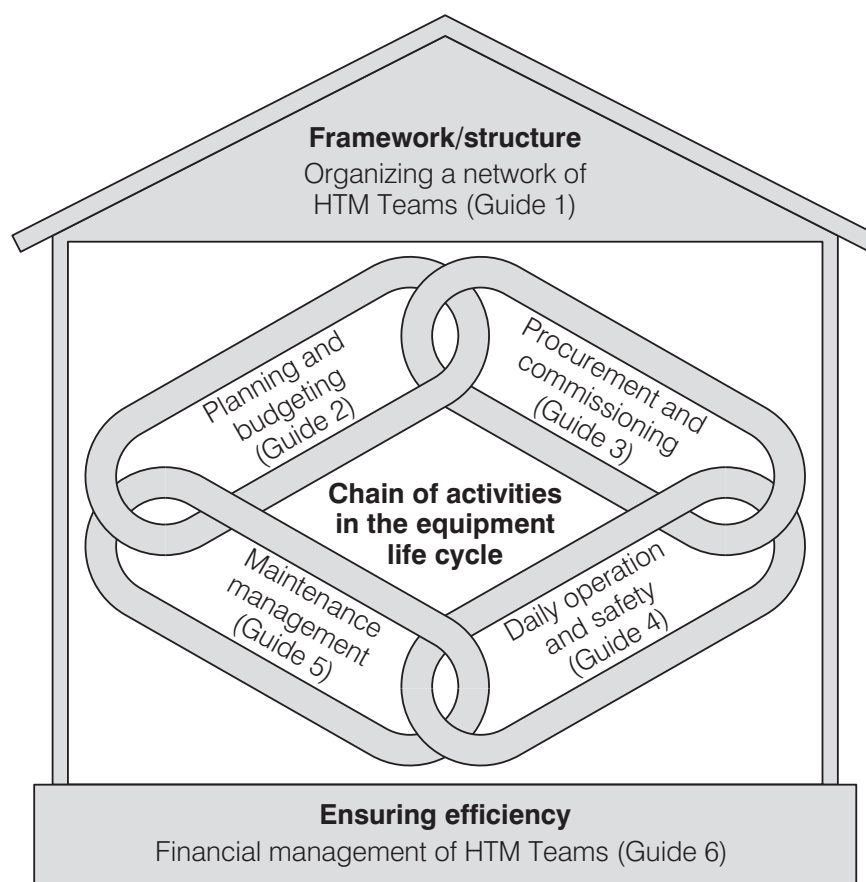

Who Are These Guides Aimed at?

These Guides are aimed at people who work for, or assist, health service provider organizations in developing countries. Though targeted primarily at those working in health facilities or within the decentralized health authorities, many of the principles will also apply to staff in other organizations (for example, those managing health equipment in the Ministry of Works, private maintenance workshops, and head offices).

Depending on the country and organization, some daily tasks will be undertaken by end users while others may be carried out by higher level personnel, such as central level managers. For this reason, the Guides cover a range of tasks for different types of staff, including:

- ◆ equipment users (all types)
- ◆ maintenance staff
- ◆ managers
- ◆ administrative and support staff
- ◆ policy-makers
- ◆ external support agency personnel.

They also describe activities at different operational levels, including:

- ◆ the health facility level
- ◆ the zonal administration level (such as district, regional, diocesan)
- ◆ the central/national level
- ◆ by external support agencies.

Many activities require a multi-disciplinary approach, therefore it is important to form mixed teams which include representatives from the planning, financial, clinical, technical, and logistical areas. Allocation of responsibilities will depend upon a number of factors, including:

- ◆ your health service provider
- ◆ the size of the organization
- ◆ the number of decentralized levels of authority
- ◆ the size of your health facility
- ◆ your level of autonomy.

The names and titles given to the people and teams involved will vary depending on the type of health service provider you work with.

For the sake of simplicity, we have used a variety of labels to describe different types of staff and teams involved in HTM.

This Series describes how to introduce healthcare technology management into your organization. The term **Healthcare Technology Management Service (HTMS)** is used to describe the delivery structure required to manage equipment within the health system. This encompasses all levels of the health service, from the central level, through the regions/districts, to facility level.

There should be a referral network of **workshops** where maintenance staff with technical skills are based. However, equipment management should also take place where there are no workshops, by involving general health facility staff. We call these groups of people the **HTM Team**, and we suggest that you have a team at every level whether a workshop exists or not. Throughout this Series, we have called the person who leads that team the **HTM Manager**.

At every level, there should also be a committee which regularly considers all equipment-related matters, and ensures decisions are made that are appropriate to the health system as a whole. We have used the term **HTM Working Group (HTMWG)** for this committee, which will advise the Health Management Teams on all equipment issues.

Due to its role, the HTMWG must be multi-disciplinary. Depending on the operational level of the HTMWG, its members could include the following:

- ◆ Head of medical/clinical services.
- ◆ Head of support services.
- ◆ Purchasing and supplies officer.
- ◆ Finance officer.
- ◆ Representatives from both medical equipment and plant maintenance.
- ◆ Representatives of equipment users from a variety of areas (medical/clinical, nursing, paramedical, support services, etc).
- ◆ Co-opted members (if specific equipment areas are discussed or specific interest or need is shown).

The HTM Working Group prepares the annual plans for equipment purchases, rehabilitation, and funding, and prioritizes expenditure across the facility/district as a whole. It may have various sub-groups to help consider specific aspects of equipment management, such as pricing, commissioning, safety, etc.

How to Use These Guides

Each Guide has been designed to stand alone, and has been aimed at different types of readers depending on its content (*Section 1.2*). However, since some elements are shared between them, you may need to refer to the other Guides from time to time. Also, if you own the full Series (a set of six Guides) you will find that some sections of the text are repeated.

We appreciate that different countries use different terms. For example, a purchasing officer in one country may be a supplies manager in another; some countries use working groups, while others call them standing committees; and essential service packages may be called basic healthcare packages elsewhere. For the purpose of these Guides it has been necessary to pick one set of terms and define them. You can then modify them for your own situation.

The terms used throughout the text are outlined, with examples, in the Glossary in *Annex 1*.

We appreciate that you may find it hard to pursue the ideas introduced in these Guides. Depending on your socio-economic circumstances, you may face many frustrations on the road to achieving effective healthcare technology management. We recognize that not all of the suggested procedures can be undertaken in all environments. Therefore we recommend that you take a step-by-step approach, rather than trying to achieve everything at once (*Section 2*).

These Guides have been developed to offer advice and recommendations only, therefore you may wish to adapt them to meet the needs of your particular situation. For example, you can choose to focus on those management procedures which best suit your position, the size of your organization, and your level of autonomy.

For more information about reference materials and contacts for healthcare technology management, see *Annex 2*.

1.2 INTRODUCTION TO THIS SPECIFIC GUIDE

The Importance of Maintenance

Healthcare technology is such an important part of healthcare today that it cannot easily be ignored. It has a very wide application: for example equipment is used to:

- ◆ help *diagnose* whether a patient has malaria
- ◆ *treat* a patient by removing their gall stones
- ◆ *monitor* the condition of a patient's heart
- ◆ provide *therapy* in order to get a patient moving about again
- ◆ *control* the environment by supplying heat and light
- ◆ *provide* necessities such as running water
- ◆ *transport* patients and staff
- ◆ *feed* patients and staff
- ◆ provide *clean* surroundings.

All equipment has a life expectancy, just as each patient does. The life expectancy will be dependent on the type of equipment and the type of technology it contains. For example, five years might be the typical life for an ECG monitor, ten years for a suction pump, 15 years for an operating table, and 20 years for an electricity generator.

Planned preventive maintenance

regularly checking that equipment works as expected and described during its different modes of operation, and that parts are all right, and adjusting settings or replacing parts when necessary in order to prevent a breakdown.

All equipment is made up of various parts – moving and non-moving, active and passive. At any time during the life of the equipment, these parts can fail due to wear and tear (this even applies to software). Thus, it is very important to give regular attention to the equipment through planned preventive maintenance (PPM) and corrective maintenance (repair).

Corrective maintenance, or repair responding to the breakdown of equipment and undertaking any work required to put right the problem in order to return the equipment to a working condition.

Depending on how well equipment is looked after, the expected life can be achieved or cut short, as shown in *Figure 3*. Thus maintenance is crucial to the ‘life’ of the equipment. If maintenance is not carried out regularly and on time, equipment will deteriorate to a state where it is beyond

economical repair; in other words it costs more to repair it than to replace it. If maintenance does not occur at all, the equipment will grind to a halt.

Figure 3: Potential and Life of Equipment With and Without Maintenance

A. With efficient technical support

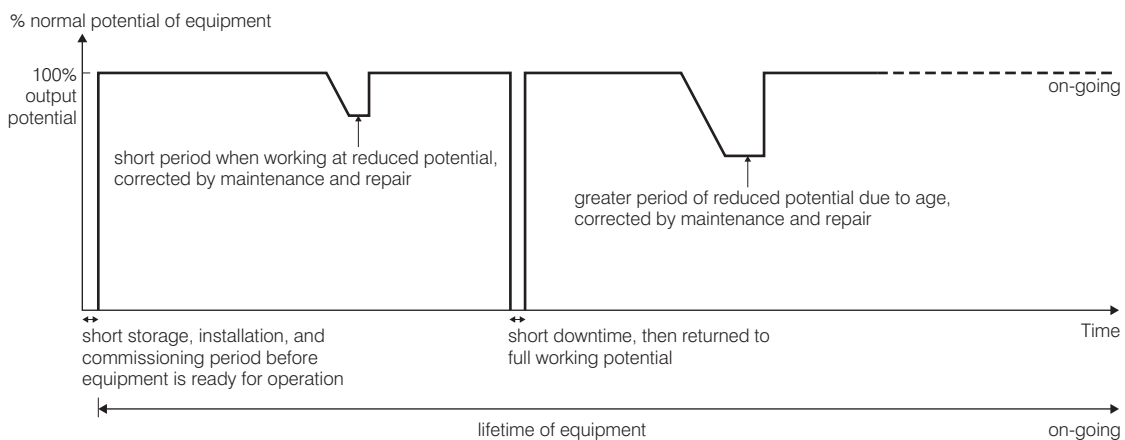

B. Without efficient technical support

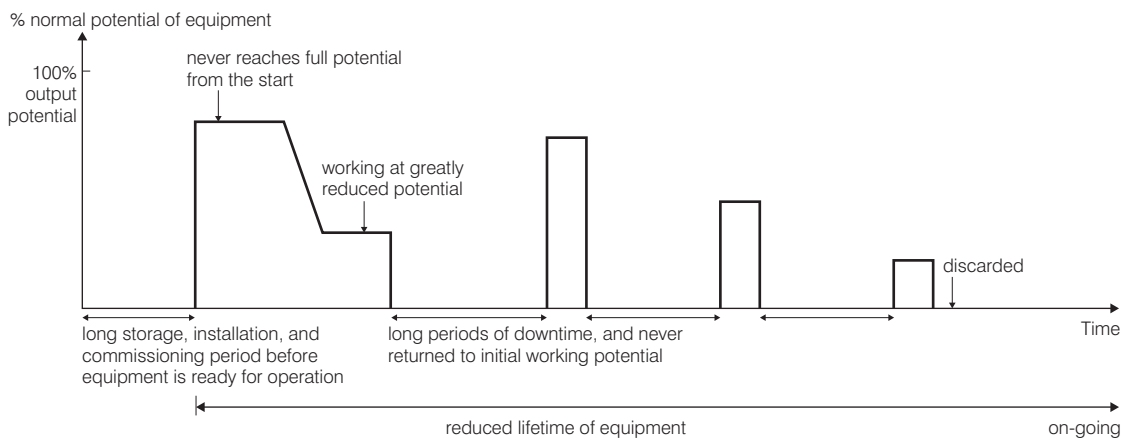

Adapted from: Mallouppas A, 1986, ‘Background document for the WHO programme on maintenance and repair of hospital and medical equipment’, WHO, Geneva, Switzerland, WHO/SHS/86.5

For simplicity, in this Guide the term ‘maintenance’ is used to cover both the preventive maintenance tasks and the corrective repair tasks required.

Who is this Guide Aimed at?

This Guide is particularly suitable for staff who are responsible for equipment maintenance issues in the health sector, whether they belong to the health service provider, or another maintenance organization which is public (such as the Ministry of Works) or private (such as a garage). Such people will include:

- ◆ staff employed in the maintenance service of your organization, such as:
 - the maintenance (technical) staff, managers, clerks, stores, and other support personnel that form the HTM Team based in a maintenance workshop
 - any small facility-level HTM Team which works without a workshop
- ◆ other types of staff who have various responsibilities relating to maintenance work, such as equipment users, managers and administrators, as well as finance, purchasing, human resources, supplies and stores personnel.

The recommendations and procedures outlined are primarily aimed at facility and district level personnel. However, the Guide also explains what the responsibilities are at all levels of the system, to help you see the bigger picture.

What Topics are Covered?

The Guide outlines a number of practical steps for:

- ◆ maintenance
- ◆ planning
- ◆ record-keeping
- ◆ managing the workplace
- ◆ stock management
- ◆ staff management.

These will help you to look after your equipment, and to continue to deliver health services.

We recognize that technical staff do much more than just maintenance and repair work; they should also be responsible for equipment management. For example they plan equipment services and manage stock, provide technical advice for procurement, operate plant, train users, and develop technical cost estimates and budget forecasts. Recommendations and procedures for all these other tasks are provided in *Guides 1 to 4 and 6* of this Series. However this Guide, *Guide 5*, concentrates solely on the maintenance responsibilities and activities.

The system introduced in this Guide provides a solid approach to managing maintenance. However, we recognize that there are other ways of organizing the maintenance services which may be more appropriate for your administrative system. The important thing is to implement a well-functioning system.

As you read through the recommendations in this Guide, you may find it useful to refer to advice in other Guides in the Series, as indicated in the text. Additional useful reference materials and contacts are given in *Annex 2*.

How is This Guide Structured?

The structure of *Guide 5* highlights that managing maintenance involves the management of many things, as shown in *Figure 4*.

Figure 4: The Structure of Guide 5

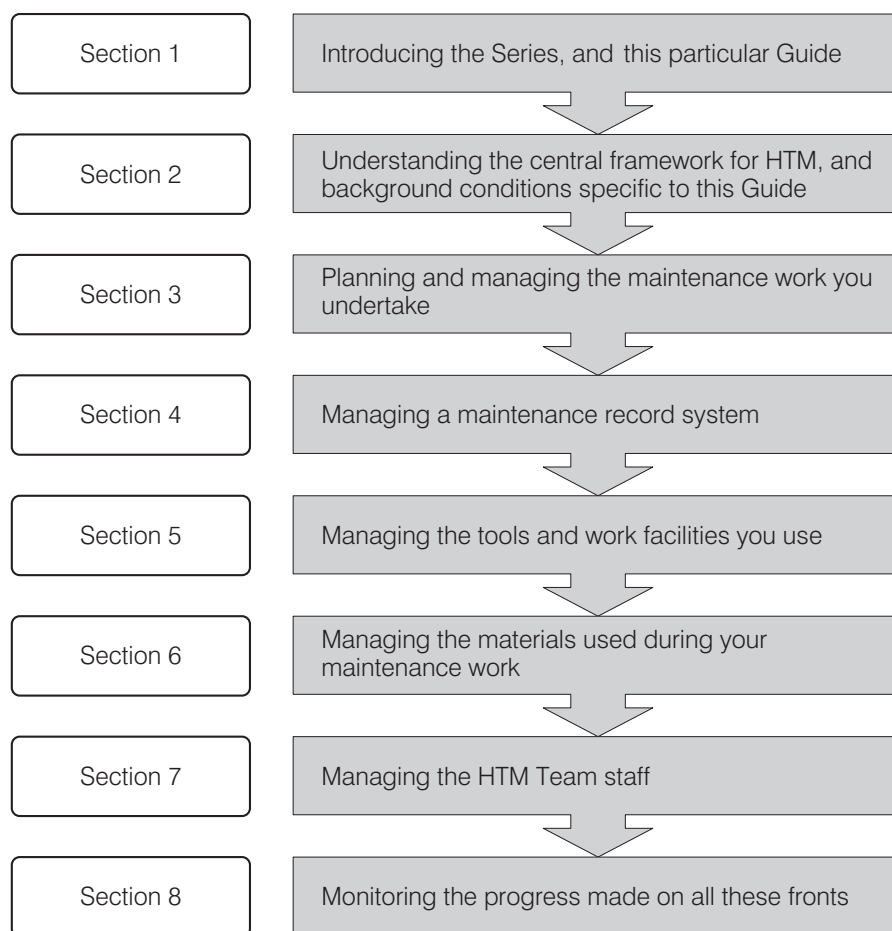

Who Does What in Organizing Maintenance?

We suggest that the HTM Working Group has a large role to play in advising the Health Management Team on all equipment matters. Depending on the size of your facility or what level of the health service you are operating at, your HTM Working Group may like to set up a number of smaller sub-groups.

In this Guide, we suggest a **training sub-group** which considers equipment-related training issues, and could include the following types of staff:

- ◆ Human Resources Manager.
- ◆ Head of Medical Services.
- ◆ Head of Support Services.
- ◆ HTM Manager.
- ◆ In-service Training Coordinator.
- ◆ Infection Control Officer, senior users, and other technicians (as appropriate to the equipment being considered).

A **stock sub-group** which evaluates the recurrent stock requirements for spare parts and maintenance materials could have the following types of members:

- ◆ Purchasing and Supplies Officer.
- ◆ HTM Manager.
- ◆ Stores Controller.
- ◆ Representatives from equipment user departments (as appropriate to the equipment being considered).

A **project sub-group** would set goals and oversee the progress of the equipment component of any large development project, in consultation with the external funding agency. Such projects may cover the maintenance service, a facility, or a district health authority. They are usually cross-sectoral and therefore will include a variety of types of staff from:

- ◆ management
- ◆ equipment user departments
- ◆ the HTM Service
- ◆ support services.



- Tip**
- There may seem to be a large number of sub-groups but the aim is to spread the work around different members of staff so that the HTM Working Group (*Section 1.1*) does not have to do everything.
 - You may have set up many of these sub-groups already to undertake work described in the other Guides in this Series. If this is the case, attending to maintenance issues will just be an extension of their existing role.
 - If you have a small health facility with few staff, the groups that form to oversee maintenance issues can be much smaller. Try to use relevant staff with experience and those who show an interest in the task.

Since equipment that is well looked after lasts a long time, it is important for maintenance to be seen as a collective responsibility in the health service. Thus many people have a role to play, as shown in *Box 3*.

BOX 3: The Collective Responsibility for Maintenance

Working Together	<p>HTM Managers (at all levels of the HTMS)</p>	<ul style="list-style-type: none"> ◆ are the key to a successful maintenance system ◆ coordinate all of the people who have a collective responsibility for maintenance ◆ plan all maintenance and repair work (<i>Section 3</i>) ◆ plan the adequate supply and stock levels of spare parts and maintenance materials (<i>Section 6</i>) ◆ monitor and control the work of the HTM Teams (<i>Sections 4 and 7</i>) ◆ monitor and control the work of external maintenance contractors (<i>Section 3.5</i>) ◆ monitor progress against targets for maintenance performance (<i>Section 8</i>)
	<p>HTM Teams</p>	<ul style="list-style-type: none"> ◆ undertake PPM and repair according to formal procedures (<i>Section 3</i>) ◆ keep a comprehensive equipment and maintenance record system (<i>Section 4</i>) ◆ plan maintenance work, cost it, and order the parts required (see <i>Guide 2</i> on planning and budgeting, and <i>Guide 6</i> on financial management) ◆ follow formal procedures for the use and care of tools (<i>Section 5</i>) ◆ train users (see <i>Guide 4</i>) ◆ monitor safe use of equipment (see <i>Guide 4</i>) ◆ perform their jobs to the best of their ability, according to their job descriptions (<i>Section 7</i>)
	<p>Equipment Users</p>	<ul style="list-style-type: none"> ◆ take good care of equipment (see <i>Guide 4</i>) ◆ operate equipment properly and safely (see <i>Guide 4</i>) ◆ undertake user PPM, and care and cleaning of equipment (see <i>Annex 4</i> and <i>Guide 4</i>) ◆ report faults promptly to their Section Heads (<i>Section 4.2</i>) ◆ educate new users (see <i>Guide 4</i>)
	<p>User Department Section Heads</p>	<ul style="list-style-type: none"> ◆ report faults promptly to the maintenance service with a Work Request/Job Form (<i>Section 4.2</i>) ◆ file these forms in order to keep an ongoing record of the requests (<i>Section 4.2</i>) ◆ monitor progress with outstanding maintenance work (<i>Section 4.2</i>)
	<p>Health Management Teams (at facility, district, regional, and central level) and their HTMWG</p>	<ul style="list-style-type: none"> ◆ are responsible for Equipment Development Planning (see <i>Guide 2</i>) ◆ liaise with and oversee the Healthcare Technology Management Service (see <i>Guide 1</i>) ◆ ensure sufficient financial and human resources are available to guarantee the effective maintenance of the equipment stock (see <i>Guide 2</i>) ◆ provide suitable space and resources for workshop facilities (<i>Section 5.3</i>) ◆ develop a policy on ownership, safety and replacement of tools (<i>Section 5</i>) ◆ ensure technical participation at management level (see <i>Guide 1</i>) ◆ train staff to understand the importance of maintenance and their role in it

Continued opposite

BOX 3: The Collective Responsibility for Maintenance (continued)

Working Together	Finance Officers	<ul style="list-style-type: none"> ◆ take into account the calculations of spare part and maintenance material usage rates, when calculating maintenance recurrent budgets (see <i>Section 6.3, Guide 2</i> and <i>Guide 6</i>) ◆ allocate sufficient funds for all maintenance costs, including tools (see <i>Section 5</i> and <i>Guide 2</i>) ◆ pay maintenance contracts promptly (<i>Section 3.5</i>)
	Purchasing and Supplies Officers	<ul style="list-style-type: none"> ◆ promptly procure the required spare parts, maintenance materials, and tools, so that equipment maintenance and repair work can take place (see <i>Sections 5 and 6</i>, and <i>Guide 3</i> on procurement and commissioning) ◆ register suitable external maintenance contractors and manage the contracting process (<i>Section 3.4</i>)
	Stores Controllers	<ul style="list-style-type: none"> ◆ make spare parts and maintenance materials stockable items in the stores system (<i>Section 6.2</i>) ◆ use a stock control system to reorder goods before stocks run out (<i>Section 6.3</i>)
	Human Resources Departments	<ul style="list-style-type: none"> ◆ hire suitably skilled operators and maintenance staff and offer attractive packages in order to retain them in post (see <i>Sections 2.2 and 7.1</i>, and <i>Guide 1</i> on organizing an HTM system) ◆ facilitate in-service training to improve the skills required for equipment (<i>Section 7.4</i>) ◆ ensure that staff performance, with regards to good and bad practice when maintaining equipment and caring for tools, is reflected in staff appraisals (<i>Section 7.3</i>)
	In-Service Training Coordinators	<ul style="list-style-type: none"> ◆ enable staff to express needs for equipment-related skills development ◆ arrange the necessary relevant training in equipment-related subjects for all staff ◆ develop training resources, and train staff according to timetables (<i>Section 7.4</i>)

2. FRAMEWORK REQUIREMENTS

Why is This Important?

In order to deliver quality health services, it is essential to undertake effective healthcare technology management.

There are various framework requirements to help you do this. These include legislation, regulations, standards, and policies.

These framework requirements create the boundary conditions within which you undertake healthcare technology management. They include central or national guiding principles, policy issues, and high-level assumptions that can impede or assist you in your work.

It is very difficult to function effectively if these framework requirements do not exist, and you should lobby your organization to develop them.

Depending on how autonomous your health facilities are, you may be able to develop these framework requirements at facility, region/district, or central level.

In most industrialized countries, laws, regulations, policies and guidelines form an indispensable part of health service management. For many developing countries, however, these regulatory procedures have yet to be developed.

Guide 1 provides a fuller analysis of how to develop these instruments, and shows that effective healthcare technology management (HTM) is essential in order to deliver quality health services. *Section 2.1* summarizes these points and offers advice on:

- ◆ the regulatory role of government
- ◆ establishing standards for your health system
- ◆ policy issues for HTM
- ◆ the importance of introducing an HTM Service
- ◆ managing change.

Section 2.2 goes on to discuss the background conditions specific to this Guide, and provides advice on:

- ◆ authorities responsible for guidance on equipment maintenance
- ◆ the organizational chart, establishment posts, staffing requirements, funding and resource issues for maintenance.

2.1 FRAMEWORK REQUIREMENTS FOR QUALITY HEALTH SERVICES

Regulatory Role of Government

The World Health Organization (WHO) identifies four distinct functions for health systems:

- ◆ The provision of health services.
- ◆ The financing of health services.
- ◆ The creation of health resources (investment in facilities, equipment, and training).
- ◆ The stewardship of health services (regulation and enforcement).

Health service provision and financing, as well as resource creation may be taken on by both the government and private sector. Thus, there are various options for organizing health systems:

- ◆ Mainly public.
- ◆ Mainly private for-profit (for example, run by a commercial organization), and private not-for-profit (for example, run by faith organizations, NGOs).
- ◆ A mixture of government and private organizations.

However in all these systems, the government is solely responsible for the regulation of health services. The reason for this is that the government has a duty to ensure the quality of healthcare delivered in order to protect the safety of the population. These regulations may then be enforced directly by government bodies or they may be enforced by publicly funded bodies, such as professional associations, which apply government sanctioned regulations.

Most governments would agree that the protection of health and the guarantee of safety of health services is vital. However, in many countries this regulatory function is underdeveloped, with weak legal and regulatory frameworks.

To regulate health services, the government should:

- ◆ adopt suitable quality standards for all aspects of health services, including acceptable international or national standards for healthcare technology, drugs, and supplies in order to ensure their efficacy, quality and safety
- ◆ establish systems to ensure standards are met, so that the bodies enforcing regulations have legal sanctions they can use if standards are infringed
- ◆ establish wide-ranging policies covering all aspects of the utilization, effectiveness, and safety of healthcare technology, drugs, and supplies
- ◆ establish systems to ensure these policies can be implemented.

For health services, the Ministry of Health is the body most likely to develop these government regulations. Other health service providers need to be guided by government laws, and should look to the Ministry of Health for guidance or follow their direction if required to do so by law or regulation.

Establishing Standards for your Health System

The government should agree on which quality standards have to be met by the health services in general. These will cover areas such as:

Standard
a required or agreed level
of quality or attainment
set by a recognized authority,
used as a measure,
norm, or model.

- ◆ procedures and training
- ◆ construction of facilities
- ◆ healthcare technology, drugs, and supplies
- ◆ safety
- ◆ the environment
- ◆ quality management.

Since drawing up these standards can be both time consuming and expensive, governments may often choose to adopt acceptable international standards (such as ISO), rather than develop their own. However, they must be suitable and applicable to your country situation and fit in with your country's vision for health services.

The adoption of suitable international or national standards for healthcare technology is of particular relevance to this Guide. Such standards would cover areas such as:

- ◆ manufacturing practices
- ◆ performance and safety
- ◆ operation and maintenance procedures
- ◆ environmental issues (such as disposal).

These are important since countries can suffer if they acquire sub-standard and unsafe equipment. Again, in the majority of cases ministries of health would save money and time by adopting internationally recognized standards. For more information on introducing internationally recognized standards into your procurement procedures, refer to *Guide 3* on procurement and commissioning.

It is not enough simply to establish these standards; they also need to be adhered to. For this reason, you should establish a national supervisory body that has the power to ensure that health service providers comply with the standards in force. To be effective, such an enforcement agency must be allocated sufficient financial and personnel resources. It should also be linked or networked with corresponding international bodies.

Much healthcare technology in developing countries is received through foreign aid and donations, but such products don't always meet international standards. Therefore, your country will need to negotiate with external support agencies. The best way to do this is to develop regulations for donors that supply equipment (see *Annex 2*, and *Guide 3*).

The legal system plays an important role in enforcing such standards, by ensuring that any infringements can be effectively prosecuted. It is therefore essential that the legal system is allocated sufficient financial and human resources to enforce claims against any institution operating equipment that does not meet the prescribed standards.

Developing Policies for Health Services

Every country needs to establish wide-ranging policies covering all aspects of health services. National health policies are usually developed by the Ministry of Health. If these policies are linked to regulations, then other health service providers must also follow them. Each health service provider can expand them internally, and must establish systems to ensure they are implemented.

One key framework requirement for this Series of Guides is that your health service provider should have started work on a Healthcare Technology Policy (for guidance on this process, see *Annex 2*). Such a policy usually addresses all the healthcare technology management (HTM) activities involved in the life-cycle of equipment, as shown in *Figure 5*.

Figure 5: The Healthcare Technology Management Cycle

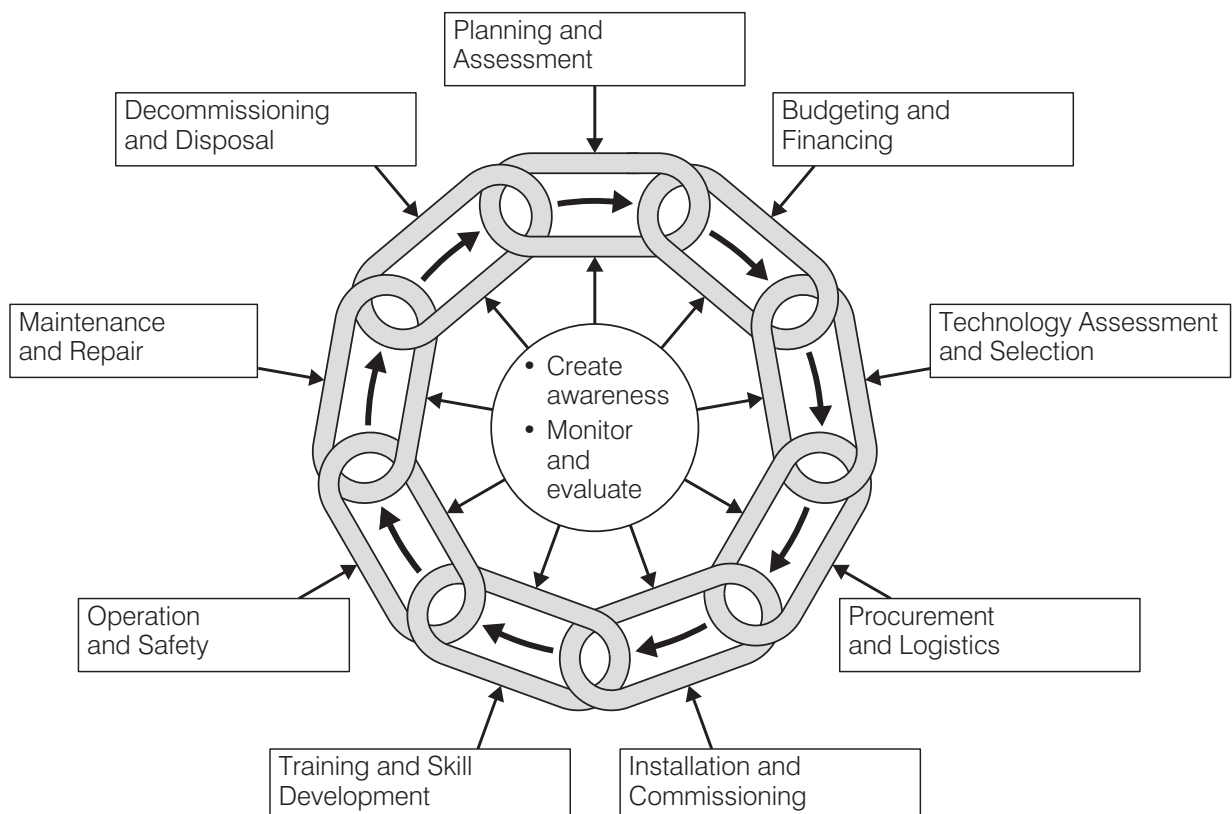

Here we will consider just four issues that provide key background conditions:

- ◆ A vision for health services.
- ◆ Standardization.
- ◆ The provision of maintenance.
- ◆ Finances.

A Vision for Health Services

Every health service provider needs a realistic vision of the service it can offer. This should include a clear understanding of its role in relation to other health service providers in the national health service. Only when this vision is known can the health service provider decide what healthcare technology is needed, and prioritize the actions required to develop its stock of equipment.

It is unhelpful if lots of individual health facilities pull in different directions, with no coordinated plan for the health service as a whole. The central authority of each health service provider should be responsible for considering what sort of healthcare should be offered at each level of their health service. Preferably they will collaborate with the Ministry of Health, or follow their guidance if regulated to do so.

If there is no health service plan, there is no framework on which to base decisions. *Guide 2* provides further information on developing a vision and planning your healthcare technology stock.

Standardization of Healthcare Technology

Standardization
(also known as rationalization, normalization and harmonization)
– the process of reducing the range of makes and models of equipment available in your stock, by purchasing particular named makes and models.

Introducing an element of standardization for healthcare technology will help you to limit the wide variety of makes and models of equipment found in your stock. By concentrating on a smaller range for each equipment type, your technical, procedural, and training skills will increase and your costs and logistical requirements will decrease (see *Guide 1*).

It is easier to achieve standardization if equipment is planned and ordered on a country-wide, district-wide or health service provider basis. It is therefore important to combine forces with other facilities or health service providers, and it may be wise to follow standardization strategies of the Ministry of Health. It is important that these standardization efforts do not just apply to products purchased by health facilities, but also to donations.

Standardizing your healthcare technology may be difficult for a number of reasons. Your country and local businesses may have their own trade practices and interests. National donors may have tied-aid practices, while the procurement procedures of international funding agencies, health service institutions, and individuals may act against your standardization strategies (see *Guide 3*).

You may need to hold discussions with organizations such as the Ministry of Industry and/or Trade, the chambers of commerce or specific business associations, as well as external support agencies. However, it is well worth persevering, as standardization offers many benefits, both in terms of cost and efficiency.

Provision of Maintenance

Proper maintenance is essential to ensure that the equipment you have purchased continues to meet the standards required throughout its entire working life.

Undertaking maintenance belongs to the service provision function of health systems, and could therefore, in principle, be carried out by the government, the private sector, or by a mixture of the two.

It is useful to organize the maintenance system along similar lines to the health service provision already existing in your country. For instance, if the health sector is predominantly run by the government, it is probably simplest to let the government run the maintenance organization as well. In contrast, if private organizations run the health services, it makes little sense for the maintenance activities to be carried out by a government body. In the majority of cases, a mixed system is most likely.

However, the government may wish to take a regulatory role and establish regulations which guarantee that healthcare technology performs effectively, accurately, and safely. The rules established are valid for all health service providers, irrespective of their type of organization.

Specific maintenance requirements would not need to be prescribed by the regulatory body. Instead, it is up to individual health service providers to decide how these will be provided. However, the nature and the complexity of some maintenance services often calls for partnerships between the public and private health service providers. Partnerships may also exist between health service providers and private sector sources of maintenance support. For more details, refer to *Guide 1*.

To provide maintenance services, you will normally need to establish good links between maintenance workshops. This will create a network that supports the needs of all your health facilities. Maintenance is, of course, only one of many HTM activities that need to be carried out. However, the fact that maintenance workshops usually already exist in most countries serves as a useful starting point for establishing a physical HTM Service across your health service provider organization and across your country. For more details on how to organize an HTMS, refer to *Guide 1*.

Finances

To ensure that healthcare technology is utilized effectively and safely throughout its life, your health service provider will need to plan and allocate adequate capital and recurrent budgets. See *Guide 2* for more advice on this.

In a government-organized system these funds have to be provided by government budgets, while private systems or mixed systems must generate the required funds from their customers, or from benefactors and donors.

Depending on your health service provider and country, your HTM Service may be able to generate income by charging for services provided. Whether this income can be used to further improve the HTM Service depends on the policies of the responsible financing authority (such as the treasury or central finance office). *Guide 6* provides advice on this.

The Importance of Introducing a Healthcare Technology Management Service

We have established the importance of:

- ◆ adopting standards for healthcare technology
- ◆ developing healthcare technology policies
- ◆ establishing systems to ensure the policy is implemented.

All these aims could be achieved if each health service provider practised healthcare technology management (HTM) as part of the everyday life of their health service. The best way to do this is to have an HTM Service incorporated into each health service provider organization.

Box 2 (Section 1.1) shows that HTM provides a wide range of benefits. *Guide 1* attempts to express this in terms of the sorts of savings that can be made if HTM is effectively carried out. Taking maintenance as an example, we can see that it not only has a positive impact on the safety and effectiveness of healthcare technology, but that it also has two important economic benefits:

- ◆ It increases the life-span of the equipment.
- ◆ It enhances the demand for health services, since demand for services is crucially dependent upon the availability of functioning healthcare technology.

Healthcare technology that is out of order quickly leads to a decline in demand, which will, in turn, reduce the income and quality of services of the health facilities. You will lose clients if, for example, it becomes known that malfunctioning of sterilization equipment may endanger the health of the patients. Similarly, patients will avoid visiting health facilities that do not possess functioning diagnostic equipment.

Thus the justification for introducing an HTM Service is that it will benefit you economically and clinically, by ensuring that healthcare technology continues to meet the standards required throughout its working lifetime.

The activities of an HTM Service belong to the service provision function of health systems. However, the government may wish to take a regulatory role and establish regulations that guarantee that HTM occurs. To achieve this, it will be necessary to have:

- ◆ a government body to provide regulations that will ensure the continued performance and safety of healthcare technology throughout its life
- ◆ a control mechanism to check that all health service providers pursue these healthcare technology management activities effectively
- ◆ legal or other sanctions that are enforceable if the rules are infringed.

The government body responsible for providing regulations could be the central level of the national HTM Service. Each health service provider could then develop its own HTM Service. It should involve a network of teams and committees that enable HTM to be practised in all facilities. In order to establish an effective HTM Service, you will need to provide sufficient inputs, such as finance, staff, workshops, equipment, and materials. Only in this way will you get the outputs and benefits that you require. For details of how to develop such an HTM Service, see *Guide 1*.

The organizational chart for the HTM Service will vary depending on the size of your country and your health service provider organization, and whether you are just starting out. However, *Figure 6* provides an example of the relationship between HTM Teams and HTM Working Groups (*Section 1.1*) that we envisage.

Figure 6: Sample Organizational Chart for the HTM Service

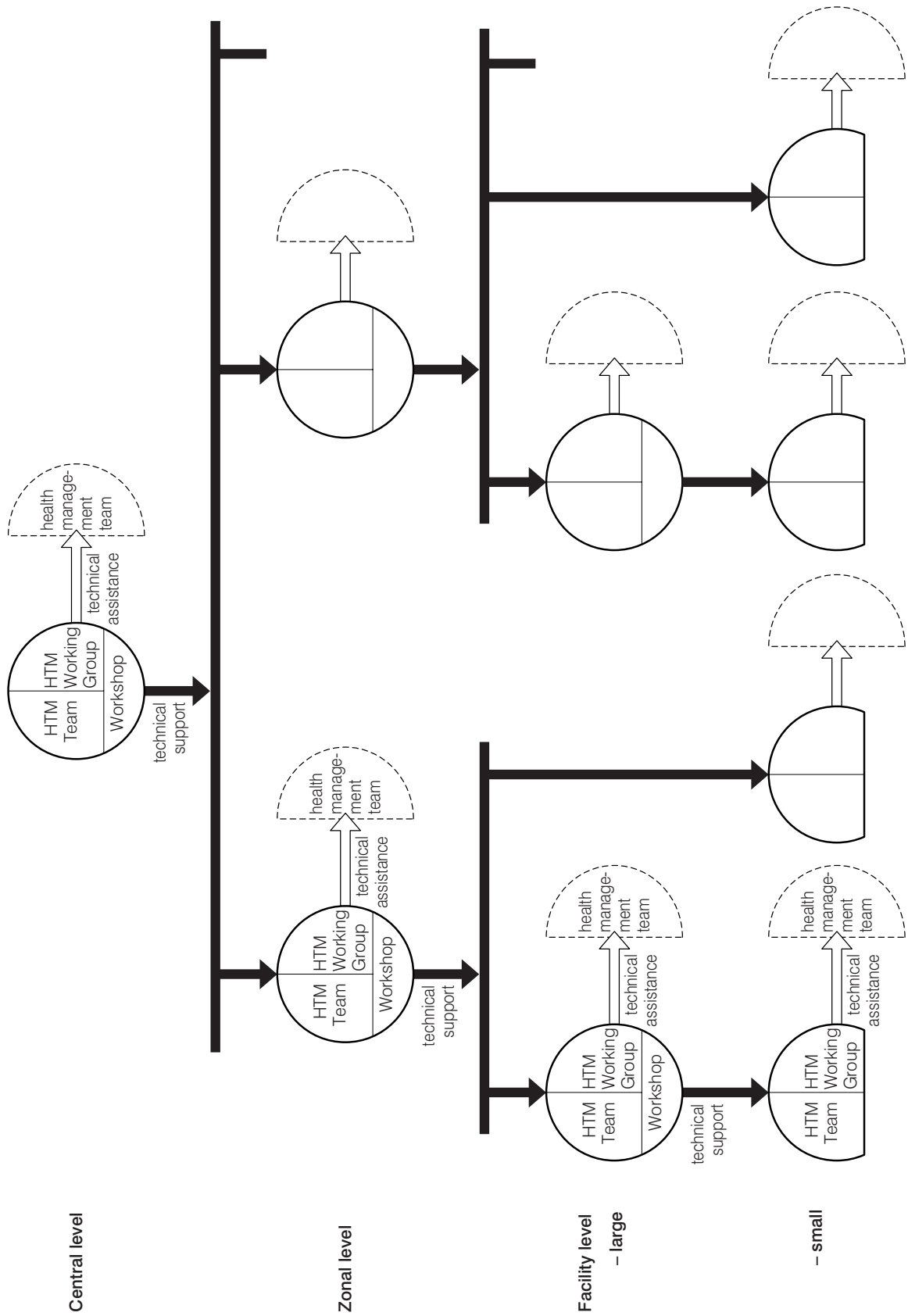

How to Manage Change

The regulatory requirements presented in this Section may appear somewhat idealistic, compared to the reality in many health systems. However, the aim is not to highlight the deficiencies of existing systems, but to provide a blueprint for a functioning healthcare technology management system. Hopefully, this will enable you to get the right framework conditions in place, and thus improve the effectiveness and the safety of your health services.

We are **not** recommending that your health service provider:

- ◆ throw out all their current HTM strategies and start again
- ◆ make sudden and sweeping changes that are likely to fail if they are over ambitious.

Rather it is better to take a step-by-step approach, introducing changes gradually, with a careful review process. To implement an HTM system with all the complexities described in this Series of Guides will take several years, and to try to achieve everything at once could be disastrous. However for healthcare technology management to improve, it is important to act.

It is possible to write down all the correct procedures and yet still fail to improve the performance of staff. To ensure that your HTM procedures are effective, it is important for there to be good managers who can find ways to motivate staff (*Sections 2.2, 7 and 8*). Simply ordering staff to implement new procedures usually does not work. It is much better to discuss and develop the procedures with the staff who will implement them. This could take the form of discussion, working groups or training workshops. People who are involved in developing ideas about their own work methods are more likely to:

- ◆ understand the objectives
- ◆ understand the reasons why processes are necessary
- ◆ be encouraged to change their way of working
- ◆ be more interested in making changes which result in improvement
- ◆ see that the aim of the HTM procedures is to improve their delivery of healthcare.

We recognize that many readers will face difficulties such as staff shortages, poor finances, lack of materials, a lack of influence and time, and possibly even corruption. Introducing new rules and procedures into a system or institution that has no real work ethic, or which possibly employs dishonest workers, will not have any significant effect.

Therefore, strategies may be required to bring about cultural and behavioural change. For example:

- ◆ When materials are short, instead of focussing upon breakages and loss, place more emphasis upon the importance of staff working hard and putting in the hours.
- ◆ Favour good managers who are seen to be present and doing what they preach.
- ◆ Encourage an atmosphere where staff are praised for good work, rather than a culture of judgement and criticism.

Introducing rules and administrative procedures alone will not be sufficient to bring about cultural change. You will also need to find ways of increasing performance and productivity, and acknowledging/rewarding good behaviour is essential. For example:

- ◆ It is better to break a tool while actively undertaking maintenance, rather than breaking nothing but never doing any work
- ◆ It is better to break a rule in an emergency (such as withdrawing stocks from stores), rather than stick to the rules and risk the possible death of a patient.

Annex 2 has some examples of useful reference materials. To bring about such changes, you will require skills in:

- ◆ managing change
- ◆ staff motivation
- ◆ effective communication
- ◆ encouragement, and
- ◆ supportive training with demonstrations.

All parties involved in the network of HTM Teams and HTM Working Groups need to participate in developing the HTM Service. This will encourage a sense of ownership of the Service and its responsibilities, and will lead to greater acceptance and motivation among staff. If you are short of skilled staff (such as technicians, managers, planners or policy-makers), you may need to obtain specialist support to assist with some of these tasks.

2.2 BACKGROUND CONDITIONS SPECIFIC TO THIS GUIDE

Your country and health service provider may have existing regulating principles and conditions which will affect, or can inform, aspects of your maintenance work. These are described in this Section.

Authorities Responsible for Maintenance

If you work for a health service provider organization, you will need to conform to:

- ◆ any regulations and guidelines concerning maintenance produced by the central management body.

Maintenance is required for all types of healthcare technology (see *Box 1*). This requires a broad spectrum of skills to cover areas such as medical electronics, electro-medical systems, carpentry, plumbing, bricklaying, electrical installations, mechanics, refrigeration, automotive work, and technical management. The range of skills present in your HTM Service will depend on the type of health service provider you work for, and the other maintenance arrangements available in your country (as described in *Guide 1* on organizing an HTM system).

In some countries, other agencies have been given the authority for the maintenance of certain types of equipment. For example, in the government sector, the Ministry of Works may be responsible for health buildings, plant, and service supply installations, the Ministry of Supplies may be responsible for furniture and office equipment, and the Ministry of Transport for vehicles. Similarly in the non-government or private sectors, there may be a Maintenance Service and/or a Logistics Division which have authority over different types of equipment. In addition, there will be national electricity supply, water supply, and telecommunication authorities with varying responsibilities for different types of equipment. In this situation:

- ◆ you will need to follow the policies and guidelines of these other agencies
- ◆ you should not interfere with equipment outside your responsibility.

However, if large groups of equipment are not being cared for adequately by these other maintenance agencies, your health service provider may need to re-negotiate the responsibilities of the different agencies in order to ensure that all the equipment the health service relies upon is in good working condition.

Ideally, the health service provider should have overall management control of all its equipment. In reality, it can be difficult to coordinate and control staff from other maintenance agencies working on health facility sites (*Section 3.5*). With many agencies involved, there is often a duplication of skills on site (such as welders, electricians, carpenters).

For this reason, it is sensible to ensure that your in-house HTM Service is multi-disciplinary, and includes the broad range of technical skills (mentioned above) necessary to cover all different types of equipment (*Section 7.1*). The staff members of such a multi-disciplinary service have one boss only (the health service provider), work together for the good of all the physical assets of a health facility and not just some of them, and pool their skills (see *Guide 1*).

Maintenance Structure in the Health Service Hierarchy

Guide 1 of this Series describes the development of an organizational structure for your HTM Service, as shown in *Figure 6*. It starts with the simplest form of HTM Team at small facility level, which can operate whether a workshop exists or not, and is comprised of general members of health staff. The organization is then based on the idea of a referral network of HTM Teams with increasing levels of technical skills. Therefore, it is important that:

- ◆ such maintenance personnel are reflected correctly in the staffing structure (organizational chart) of the health service.

Maintenance staff need to report to a manager who has sufficient knowledge and authority to bring forward the needs of the maintenance service. Thus, the HTM Managers should be senior technical staff, and higher up the HTMS they should be professional engineers. The Head of the HTMS will be heading an important organization-wide – and even a country-wide – service.

HTM Managers (at all levels) should preferably report directly to, and be members of, their Health Management Team. They should be seen as an equal to other sector managers such as administrators, and heads of medical services, and should not have to report through these officers but have direct access to top management.

Guide 1 describes how HTM should be incorporated into the health management system, using HTM Working Groups at each level to advise the Health Management Team. **Appropriate members of the HTM Team should therefore be involved in management committees** at facility, district, regional, and central levels in order for:

- ◆ a technical viewpoint to be present in health planning decisions
- ◆ equipment management to be seen as a collective responsibility for all health staff.

The organizational structure for the HTMS (*Figure 6*) provides a professional reporting structure for technical staff. Thus, technical staff should:

- ◆ work according to the policies of the Central HTM Team and Working Group which coordinates the HTM Service
- ◆ work according to the technical guidelines of the largest central workshop
- ◆ investigate the regulations developed by the maintenance services of other health service providers in your country.

If maintenance staff in your organization are not adequately represented on management bodies, and have no professional service to take care of their needs, it will be very difficult for them to be effective in their jobs. In this case, you should lobby your health service provider to consider the role of maintenance staff and develop a suitable staffing structure for them within the health service.

Establishment Posts

It is very important that your organization creates suitable establishment posts for the members of the HTM Service (see *Guide 1*). These are required so that staff can be recruited, hired, and placed in post in the first place. A well thought out structure of posts with different entry points, qualification requirements, salaries, etc, will also help with career progression. Many countries just starting to develop their HTM Service face great difficulties because they need technical staff but have no suitable posts, or because they hire them against other unsuitably-graded posts.

The HTM Service will require a range of different types of staff including general health staff (equipment users), artisans (craftsmen), technicians, technologists, engineers, and HTM managers, as well as support staff such as clerks, secretaries, storespersons, labourers, drivers, cleaners, etc (see *Guide 1*).

The ability to develop posts for these individuals is dependent on negotiations with certain bodies. For example, in the government sector, a body such as the Public Service Commission is involved. Similarly, in the non-government or private sectors, the personnel division or a department dealing with the structure of the organization will be involved. Therefore:

- ◆ you will need to follow the guidelines and procedures set by these bodies concerning suitable entry points and routes for career progression
- ◆ if there are insufficient posts for the HTM Service, you should lobby your health service provider to establish a suitable structure.

Job descriptions are valuable tools for managers, enabling them to:

- ◆ identify suitable candidates for each post
- ◆ make the best use of the staff available
- ◆ plan for further training
- ◆ recruit suitable people.

Guide 1 provides sample job descriptions for key maintenance staff.

Staffing and Skills Levels

If your health service provider is to guarantee the good physical condition of its equipment, it needs to recruit enough staff, with the necessary skills (*Section 7.1*), for the HTM Service. Adequate training for maintenance staff and managers is necessary if you are to fill the wide variety of maintenance posts, and ensure specialists for many technical disciplines are available. It will be very difficult to ensure effective equipment maintenance without sufficiently skilled staff. Thus your organization will need to offer adequate recruitment packages so that technical staff can be retained in employment.

Ideally the HTMS will be able to pursue strategies (*Section 7.3*) to:

- ◆ motivate their staff
- ◆ evaluate staff performance
- ◆ use staff appraisal as a positive tool to develop staff skills and enable career progression
- ◆ discipline staff when necessary.

However, their ability to achieve these goals will depend on the type of human resource policies and procedures developed by your health service provider.

In addition, the central level of your organization usually plays a significant role in, among other things:

- ◆ developing training plans
- ◆ organizing and providing training scholarships
- ◆ approaching external support agencies to finance training programmes.

Staff training needs should be addressed at every level by an overall Equipment Training Plan. This is an ongoing programme of in-service training. The development of such a plan is described in *Guide 2* on planning and budgeting, and should be financed by your health service provider. It will also need to develop a clear policy on what form of 'bonding' you will use to ensure that a member of maintenance staff sent for training remains with the health service on their return. Such conditions should cover both rewards for staying and liabilities for leaving.

Maintenance Funding

The work of the HTM Teams can only go ahead and be effective if adequate budgets are planned and allocated by your health service provider. These budgets need to cover all maintenance expenditure requirements, including the supply of:

- ◆ spare parts
- ◆ tools
- ◆ other maintenance materials
- ◆ external maintenance contracts.

Guide 2 of this Series provides advice on how your health service provider can plan and budget for maintenance work. You will need to work within the financial resources allocated to you. In addition, the HTM Teams will have to follow the financial policies and procedures of your organization, in order to ensure that stock management and expenditure accounting is carried out according to the regulations.

Depending on your health service provider and country, the HTM Service may be able to generate income by charging for the services it provides. Whether this income can be used to improve the HTM Service further will depend on the accounting policies of the responsible finance authority, such as the treasury (in the government sector) or a central finance office. *Guide 6* of this Series provides advice on how to manage the finances of the HTM Service, including the possibilities for generating income.

Maintenance Facilities and Resources

If maintenance work is to be undertaken effectively, your health service provider will need to provide the facilities and resources that the HTM Teams require (*Sections 5 and 6*), such as:

- ◆ sufficient secure workshop facilities (or maintenance rooms) equipped with suitable tools and test equipment
- ◆ adequate supplies of maintenance materials and spare parts stocked in suitably located stores
- ◆ office space including adequate filing facilities and space for record-keeping
- ◆ adequate supplies of stationery for record-keeping
- ◆ adequate technical reference material and access to information
- ◆ adequate access to transport by maintenance staff so that they can carry out their tasks.

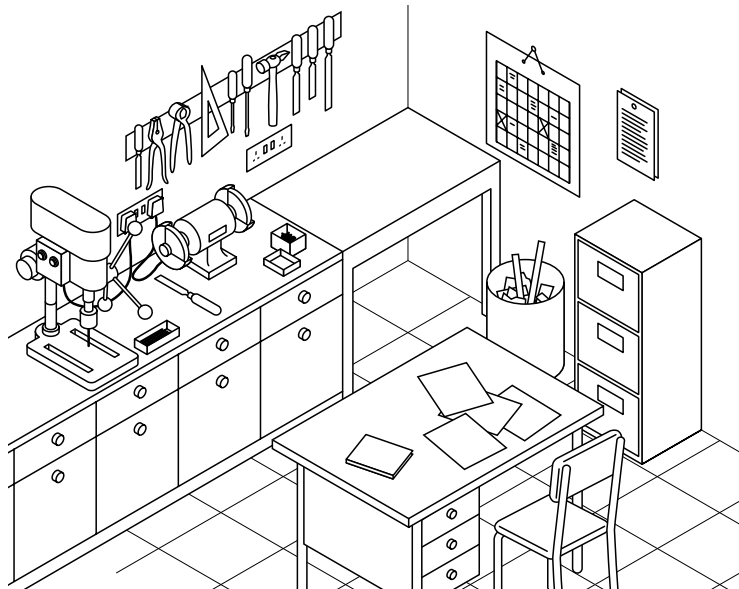

It will be very difficult to undertake the necessary maintenance work if this full range of resources is not available, and you will need to lobby your health service provider to ensure they are provided.

Box 4 contains a summary of the issues covered in this Section.

BOX 4: Summary of Issues in Section 2 on Framework Requirements

Quality Health Services	Government	<ul style="list-style-type: none"> ◆ actively regulates health services, whether they are delivered by public providers, private providers, or a mixture of the two ◆ develops checking systems and legal sanctions for infringement of health regulations ◆ adopts suitable standards for quality health services, in general ◆ specifically for healthcare technology, adopts standards for: <ul style="list-style-type: none"> - design, development, and manufacturing - performance and safety - use and training - waste disposal ◆ develops donor regulations to ensure all equipment received through foreign aid and donations also complies with the standards ◆ establishes public or quasi-public supervisory bodies to enforce regulations and standards
	Ministry of Health	<ul style="list-style-type: none"> ◆ develops national policies for health services ◆ specifically develops a Healthcare Technology Policy to cover all healthcare technology management activities including: <ul style="list-style-type: none"> - a vision - an element of standardization - the provision of maintenance - provision of finances for all HTM activities - the organizational structure for an HTM Service ◆ regulates on these issues (if required) ◆ develops an HTM Service made up of a network of teams and working groups ◆ uses the central level of the HTMS as the national regulatory body, if necessary, and to ensure that HTM policies are implemented ◆ provides sufficient inputs to ensure the HTMS is effective ◆ uses strategies to manage the changes involved carefully, so that they can be successful
	All Health Service Providers in general	<ul style="list-style-type: none"> ◆ conform to regulations and guidelines provided by government ◆ conform to the standards set by government ◆ follow the policies of the Ministry of Health if regulated to do so ◆ develop their own internal Healthcare Technology Policy and expand strategies ◆ develop their own HTM Service made up of a network of teams and working groups, with sufficient inputs to ensure it is effective, in order to ensure that HTM policies are implemented ◆ follow MOH regulations on the HTMS if regulated to do so ◆ implement strategies to develop skills in managing change, staff motivation, effective communication, encouragement, and supportive training with demonstrations ◆ introduce rules and procedures using discussion, working groups, training workshops, etc with the staff that will implement them ◆ include all parties involved in the network of HTM teams and working groups in the development of the HTMS ◆ introduce changes to HTM step-by-step, with a careful review process

Continued overleaf

BOX 4: Summary of Issues in Section 2 on Framework Requirements (continued)

Organizing Maintenance	All Technical Staff and Managers	<ul style="list-style-type: none"> ◆ Conform to regulations and guidelines provided by relevant bodies on: <ul style="list-style-type: none"> - in-house maintenance responsibilities - equipment under the responsibility of other maintenance agencies - their place in the organizational chart and reporting routes - working to their job description - skill development and career progression opportunities - financial management - control of stocks and resources
	Health Service Providers	<ul style="list-style-type: none"> ◆ retain overall management control of all its equipment, develop multi-disciplinary maintenance teams and, if necessary, re-negotiate the responsibilities of outside agencies who are performing poorly ◆ develop a suitable organizational structure for the HTM Service, correctly reflect maintenance personnel in the staffing structure of the health service, and ensure HTM is incorporated into the health management system (see <i>Guide 1</i>) ◆ set up sufficient suitable establishment posts and job descriptions for the members of the HTM Service to create adequate career progression, through consultation with the relevant regulatory body (see <i>Guide 1</i>) ◆ develop human resources policies and procedures to ensure staff career development and help motivate staff ◆ establish an Equipment Training Plan (see <i>Guide 2</i>) ◆ develop financial policies and procedures which will ensure adequate funds for equipment maintenance, and effective stock management ◆ provide sufficient maintenance facilities and resources for HTM Teams to carry out their responsibilities

3. HOW TO PLAN MAINTENANCE WORK

Why is This Important?

You need to prioritize how best to respond to the wide range of maintenance and repair requests, with the resources available to you.

You also need to decide how best to use the skills available within your health service provider organization, those from other organizations, and those in the private sector.

You need to plan your maintenance work if you are to be effective. In this Section the planning requirements are discussed through the following issues:

- ◆ Priority setting and work allocation (*Section 3.1*).
- ◆ Repairs/corrective maintenance (*Section 3.2*).
- ◆ Planned preventive maintenance (*Section 3.3*).
- ◆ Safety and calibration testing (*Section 3.4*).
- ◆ Site and contract management (*Section 3.5*).
- ◆ Managing outreach work (*Section 3.6*).

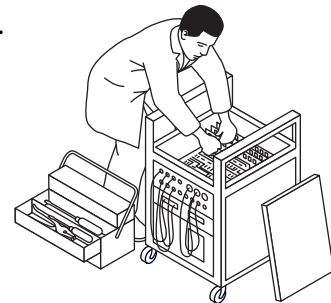

3.1 PRIORITY SETTING AND WORK ALLOCATION

Range of Tasks

The work of the HTM Team will include both maintenance and repair tasks which will be planned or unplanned:

Repair, or corrective maintenance	is undertaken when equipment has broken down, and is required to return the equipment to a working condition.
Preventive maintenance	is work undertaken to try and retain equipment in a working and safe condition and prevent it from breaking down or becoming a hazard.
Planned work	is arranged by the HTM Manager at facility or workshop level, and includes regular servicing, rehabilitation, and planned preventive maintenance (PPM) tasks.
Unplanned work	occurs in response to equipment user demands and includes breakdown and emergency repairs.

Some maintenance and repair tasks can be undertaken quickly and don't affect the work of the user department. More complicated tasks require the complete shutdown of the equipment and therefore cause a temporary halt to the services provided by the user department.

With such a range of tasks, it is useful to **prioritize your work**. During the initial setting up of maintenance services and for periods of heavy commitment, the way you plan your maintenance and repair work can be organized according to how important the equipment is for clinical operations. For example, one suggestion is to concentrate on:

plant covering:

sterilization

electricity supply (including the generator)

water supply

laundry

refrigeration

kitchen

steam for heating

sewage and sanitation installations

cooling/air-conditioning (if climate is very hot)

medical equipment covering:

operating theatres (suction pumps, etc)

syringes

anaesthetics

basic laboratory (microscope, etc)

ultrasound (maternal/obstetric)

X-ray departments

labour/delivery

basic diagnostics (BP machines, etc)

Contrary to popular belief, sophisticated and electronic medical equipment is not always the most important to maintain. In terms of patient care and comfort, items such as sufficient water, power generation for operating theatres, effective sterilizers, and good beds are of greater importance than ECG or X-ray machines. *Box 5* shows a strategy used by some maintenance services for working out which equipment should be the first priority for their attention.

Healthcare technology will, of course, be present in the buildings of each health facility. However, it is important to remember that it will also be present in the staff accommodation and training facilities that belong to the health service provider.

BOX 5: The VEN (or VED) System for Prioritizing Maintenance

Maintenance organizations in several countries use a VEN (VED) system which helps to set priorities for maintaining equipment and deciding who will undertake the work. Under this system, you do not simply consider the value or complexity of the equipment, but you consider the effect on health service delivery if the equipment is not available for use. Thus items are categorized as:

- | | |
|--|---|
| Vital | – items that are crucial for providing basic health services and should be kept functioning at all times (for example, electrical generator, operating theatre light, suction pump in the theatre, mortuary refrigerator) |
| Essential | – items that are important but are not absolutely crucial for providing basic health services and a period when they are out of operation can be tolerated (for example, suction pump in a ward, dental compressor, physiotherapy ultrasound) |
| Not so essential/
Desirable | – items that are not absolutely crucial for providing basic health services. In other words, it is possible to adapt and plan around their absence if they are out of operation (for example, ECG recorder, lift, a back-up X-ray machine). |

The same types of equipment can have various different classifications depending on their location. For example a microscope may be considered 'vital' in the main laboratory but only 'not so essential/desirable' in the out-patients department.

For equipment which is 'vital' and must be available at all times, use a maintenance agency that has a quick response and turn-around time. In some countries, this will be the in-house team for immediacy, the manufacturers' emergency call-out service, or local, efficient maintenance contractors.

In the case of equipment which is not essential and its removal from service can be accommodated, use an agency with a slower response time. In some countries, this will be the in-house team, manufacturers based abroad or a long distance away, or local maintenance firms which it takes time to contract.

Aims

As in healthcare, preventing failures is more efficient than concentrating on correcting them. Repairs are always expensive as they require highly specialized personnel and often costly spare parts. By inspecting and servicing regularly, using service manuals and checklists, the impact of maintenance is maximized and the costs are minimized. Thus it is important to introduce a planned preventive maintenance (PPM) system.

It will never be possible to completely avoid the need for repairs. But by taking a preventive maintenance approach, any repairs that do arise are more likely to be within the capabilities of the in-house HTM Team, rather than crisis breakdowns which can do extreme harm to equipment.

Some HTM Teams spend all their time responding to crises only. Your aim should be to slowly introduce more and more PPM; over time this will actually reduce the number of breakdowns and the number of repairs required. This change in the type of work done will enable the work of the HTM Team to be planned over the long term, rather than simply being in response to emergencies.

Did you know?

A number of investigations have shown that, of the equipment problems reported, approximately:

one-third arise from operator problems

one-third arise from minor, easy-to-solve technical problems (such as a blown bulb or fuse, or a loose power cord)

only one-third require more serious fault-finding procedures and special knowledge of the equipment.

So at least two-thirds (and maybe as much as 80%) of the problems could be corrected by properly trained equipment users. Leaving, at most, one-third of the problems which require specially trained maintenance personnel.

As the statistics above show, it is vital to prioritize the training of equipment users, in order to ensure the correct care and handling of equipment. *Guide 4* of this Series covers the management procedures for the daily operation and safety of equipment.

In order to plan the work and allocate it to suitable maintainers, the maintenance service requires:

- ◆ a fault reporting system (*Section 4.2*)
- ◆ a system for allocating work according to the skill, workload, and responsibility of the different members of the multi-disciplinary HTM Teams (see below)
- ◆ an outreach system so that maintenance staff can travel and undertake repairs and supervision at various locations (*Section 3.6*)
- ◆ methods for ensuring the safe completion of work: these will require safety and calibration testing equipment (*Sections 3.4 and 5*)
- ◆ suitable contracts with external maintenance organizations (*Section 3.5*)
- ◆ a way of measuring how well the HTM Teams are coping with their workloads (*Section 4.3*).

Who Should do the Maintenance and Repair Work?

There are a variety of sources of support for maintenance and repair. The main decision is whether to use the in-house team within your organization, or whether to out-source to an external agency under contract.

Did you know?

Some people believe: in-house maintenance departments can take care of everything themselves.

However: this belief is over-confident, presumptuous, and costly in terms of equipment down-time and well-being.

Some people believe: out-sourcing all maintenance and repair to an outside service enterprise reduces the administrative workload.

However: this belief is fashionable, very expensive, and diminishes the technical know-how within the health service.



- Tip** • Experience shows quite clearly that only a well-balanced **mix** of in-house and private maintenance and repair services leads to results that are both technically and financially satisfactory in settings with limited resources.

As the statistics in the panel on the previous page show, anything from one-third to two-thirds of problems may be of a simple nature, and therefore could best be carried out by in-house personnel. For the rest, more complex work is required. For these tasks you have a number of options:

- ◆ If your organization has a referral network of maintenance workshops with increasing levels of technical skills (*Section 2.2*), the more experienced and highly qualified staff will be able to offer some of the technical solutions.
- ◆ You can make use of whatever range of other sources of support are available (such as maintenance teams from other health service providers, other ministries, training institutions, and non-governmental organizations – see *Guide 1* on organizing an HTM system, and *Section 3.5*).
- ◆ There may already be agencies responsible for maintaining certain items of health service equipment (for example, the Ministry of Works may look after plant, and the national telecommunications authority may look after telephones and switchboards – *Section 2.2*).
- ◆ For much of the sophisticated work, the private sector (if available) may be the right choice. Some tasks on certain pieces of equipment can only be undertaken by the manufacturer (such as calibrating anaesthetic vaporizers, or fault-finding software for computer controlled equipment).

You must determine which types of equipment the in-house HTM Teams should be allowed to attempt repairs on, and at which levels of the HTMS. This will depend on:

- ◆ the type and complexity of technology
- ◆ the nature of the fault
- ◆ the skills of the maintenance staff
- ◆ the tools, test equipment, and spare parts available.

Such factors will vary depending on your country, health service provider, the skills within the HTMS, and the referral network of maintenance workshops that you can call upon for support. *Guide 1* (on organizing an HTM system) provides examples of the skill levels required for different maintenance tasks. The level of technical skill required depends on the type of maintenance problem and the types of healthcare technology you use, and will dictate the types of staff needed (see *Annex 3* for a summary). Factors to consider when deciding to out-source maintenance are:

- ◆ the availability of manufacturers' representatives locally (in your country or a neighbouring one)
- ◆ the technical skills available in the private sector
- ◆ which agencies have a quick response and turn-around time (see *Box 5*).

When PPM is undertaken regularly (in other words, daily or weekly) it requires the permanent presence of maintenance staff. Even when it is undertaken at less frequent intervals (such as monthly or quarterly) most developing countries will find it too expensive to ask an outside maintenance contractor to undertake the PPM, even if a suitable company were based nearby.

Bringing in people once or twice a year to check some sophisticated laboratory or X-ray equipment, or to cover a group of anaesthetic machines or ventilators, could be worth the expense. Every health service provider will need to work out its policy on PPM and repair contracts on the basis of:

- ◆ equipment needs
- ◆ climate
- ◆ its own skills
- ◆ the availability of private expertise
- ◆ available budgets.

Remember, the aim of the HTM Service is for equipment management (and maintenance) to take place even where there are no workshops (*Section 2.2*). This can be done by incorporating general health staff into the first (simplest or lowest) level of the in-house maintenance service, based in each health facility. These HTM Teams can be made up of a handful of suitable (and interested) staff such as a nurse, clinical officer, and administrator.



Experience in Madagascar

In Madagascar, a maintenance system is being developed in Majunga Province that uses existing health workers at sub-district level without workshop facilities. The health workers are called 'Agents de Maintenance'. They look out for technical problems and coordinate maintenance interventions with their provincial workshop. They are being trained by workshop staff and equipped with a set of tools to undertake some of the work themselves.

To date, the 'Madagascar Model' has worked more effectively than expected. The main reason is that the individuals involved have experienced an increase in prestige, and have started to utilize their newly acquired know-how outside their work, enabling them to supplement poor salaries. The personnel made responsible for maintenance are being supported and supervised by the technicians of the provincial workshop and, hopefully, in future, by the provincial supervision team.

As there is a vast array of equipment to look after within the health service, some strategies are required for spreading responsibility among different members of the health team. Box 6 shows one example.

BOX 6: Example Strategy for Spreading Responsibility for Maintenance Among the Health Team

What should the HTM Team do?	If there is only a small HTM Team, it may be necessary to strike the right balance between competing demands for their attention. It may be best to allow them to concentrate on the specialist maintenance requirements of the equipment within the health facility.
What should other staff do?	The basic maintenance tasks which arise at accommodation sites could be left as the responsibility of the tenants (general health staff), especially as such work requires transport for the HTM Team and pulls them away from the health facility site.

Allocating Work

Job allocation should be the overall responsibility of the HTM Manager (or his deputy). All job requests should be received and recorded by a member of the HTM Team (*Section 4.2*), who then liaises with the HTM Manager and passes them on to the relevant maintenance agency. This agency may be:

- ◆ your HTM Team
- ◆ a larger workshop within the HTMS network
- ◆ a maintenance contractor
- ◆ other sources of support.

The decision on which to use will be based on the skills available in these agencies.

Even the smallest HTM Team made up of general health staff and no technical personnel (see sub-section above), should have a number of responsibilities at facility level. They should:

- ◆ oversee the condition and running of equipment on a daily basis
- ◆ be the contact point for all equipment and maintenance matters
- ◆ be responsible for finding the correct solution (for example, calling in technical support from the workshops, or external contractors)
- ◆ possibly undertake the PPM and repair themselves (if it is a job for which they have been trained).

Methods are then required to record the work undertaken and monitor progress (*Section 4.3*). The HTM Manager should involve the team members in a weekly work-planning meeting (*Section 7.2*). Planning the week's work is based on the information kept in the Maintenance Record System (*Section 4*), which shows which jobs are still outstanding (have not been finished) and what is required to tackle them.

3.2 REPAIRS/CORRECTIVE MAINTENANCE

Types of Problem

Equipment users must be required to report faults and breakdowns promptly (*Section 4.2* describes a fault-reporting system). Many of these will be emergencies, which must be attended to as quickly as possible in order to avoid serious consequences to the equipment or its environment (for example, a boiler explosion, a disintegrating engine piston, the collapse of a wall).

If there is no back-up equipment, a breakdown will mean that the service the equipment was providing will come to a halt. For example, it may mean that the health facility:

- ◆ has no water, due to a broken pump
- ◆ cannot fill teeth, due to a broken dental drill or compressor
- ◆ cannot confirm a diagnosis, due to broken laboratory equipment.

For reported faults, it may be possible to correct the problem while the equipment is still in use. This is known as **running maintenance**. On the other hand, the equipment might have to be taken out of service. This is known as **shutdown maintenance**, and again requires the work of the user department to be suspended.

Some equipment can be repaired in situ while the maintainer is present at the health facility. Examples include:

- ◆ large installed items which cannot be moved (such as a laundry roller-ironer)
- ◆ items with a simple problem that can easily be fixed
- ◆ items for which the maintainer has tools and spare parts with him
- ◆ items that don't need a special environment (such as an anti-static, electronically clean room)
- ◆ jobs that won't be too messy (don't produce large quantities of oil or material debris, for example).

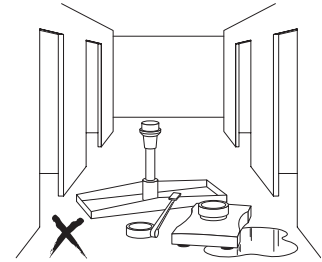

In these instances, it is important that the maintenance staff are trained to work safely and not create dangerous hazards for other health staff going about their business (for accident prevention, see *Guide 4*).

Other broken equipment, however, must be taken back to the workshop for repair.

For all these reasons, it is important to keep the equipment users informed of how long their department will be out of action. Providing such feedback is discussed in *Section 7.2*.

Maintainers' Response

In some cases a reported fault can be diagnosed and corrected from a distance. Such technical support can be offered if the users can discuss the problem with the maintainer over the telephone, fax machine, radio, or by email.

It is important that users do not assume they can fix broken equipment, as they may damage it further. Instead, they should rely on the help and advice of the HTM Team in their health facility. Even a small team made up of general health staff (with no technical personnel) should be responsible for finding the correct solution (for example, calling in technical support from a workshop, or external contractor), or possibly undertaking the repair themselves (if it is a job for which they have been trained).

For all faults and breakdowns, the first step for the maintainer is to investigate what the problem might be. It is important that equipment is not damaged further while it is being repaired, and that the end result is a fine piece of working equipment. Thus, maintenance staff require strategies when approaching a faulty piece of equipment. *Figure 7* provides some good practice strategies for maintenance staff when they are fault-finding.

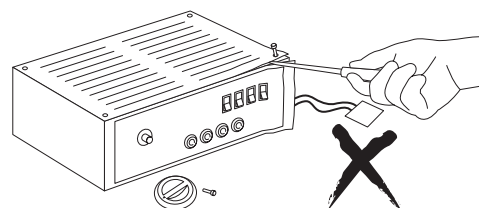
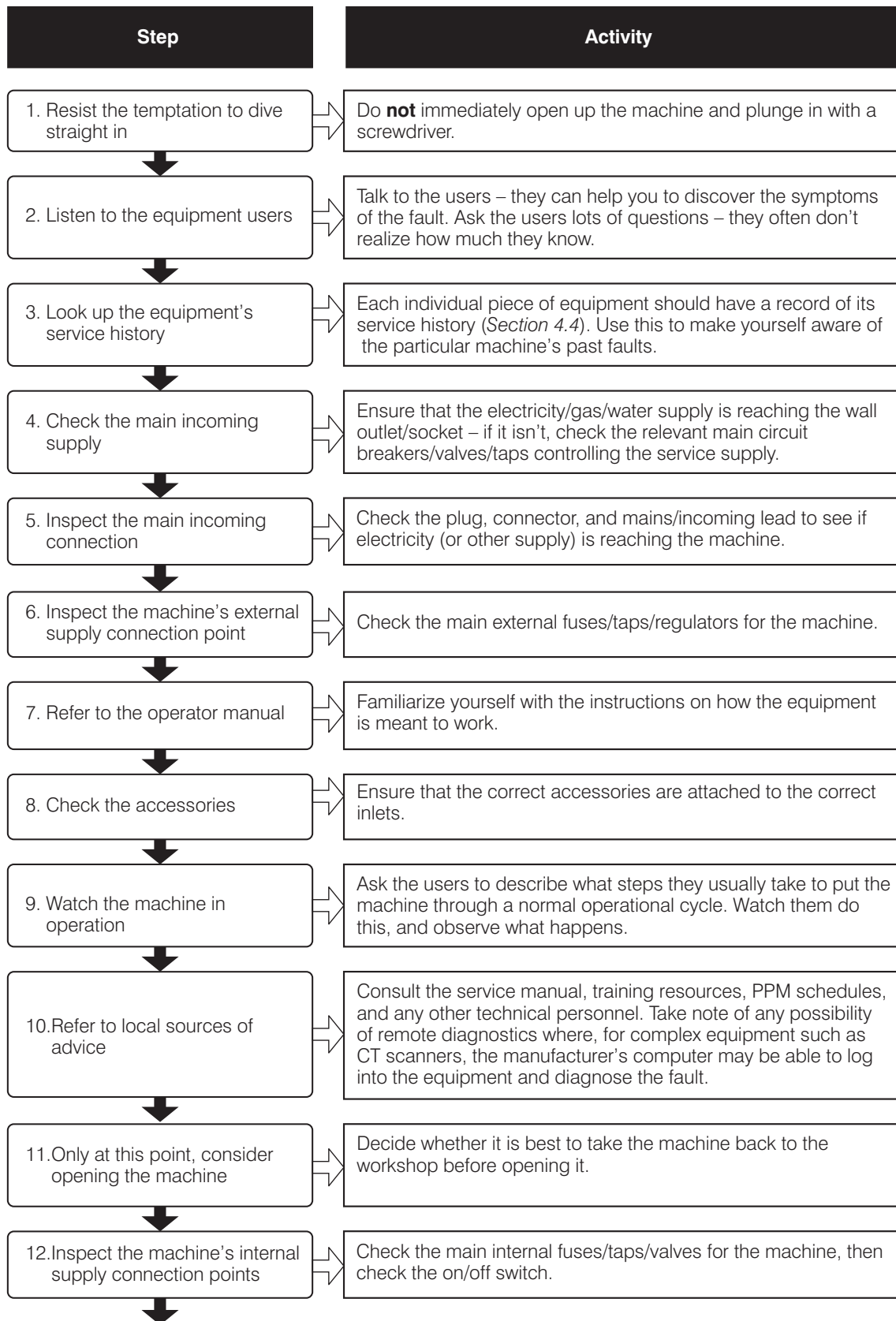
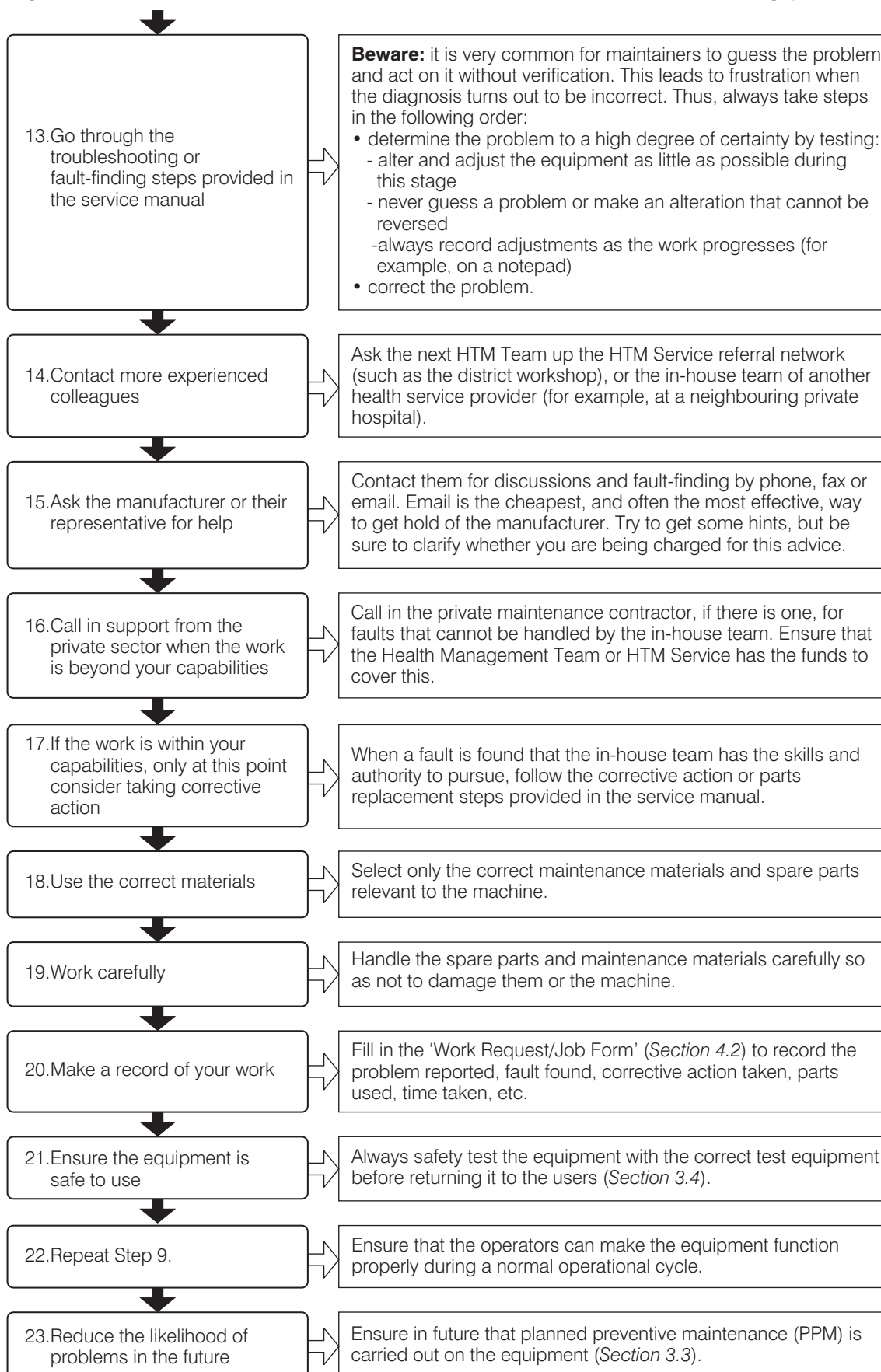

Figure 7: Good Practice Checklist for Maintenance Staff When Fault-Finding



Continued opposite

Figure 7: Good Practice Checklist for Maintenance Staff When Fault-Finding (continued)



3.2 Repairs/corrective maintenance

Some items of equipment will be found to be damaged beyond repair. These will have reached the end of their lives, and must be taken out of service (decommissioned) and be replaced if the service they provide is to continue. *Guide 4* on operation and safety provides the policies and procedures for decommissioning equipment at the end of its life.

To respond well to maintenance needs, maintenance staff need access to written references to help them with their work. It is common for such data to be missing from health facilities and even workshops, and for manuals arriving with new equipment to go missing. Attempts are required to develop a library of technical literature, reference materials, and equipment manuals. *Box 7* provides some strategies for developing such a library; although we recognize that following the recommendations provided will require time, staff input, and money.



- Tip** • Data which costs a lot of money to obtain could be collected by the Central HTM Team, which should then share the information around the HTM Service network.

BOX 7: Strategies For Sourcing Useful Literature and Advice (see Annex 2), and Expanding your Library

Strategy	Type of Material/Information	Action
Obtain literature which is usually available free of charge for equipment, spare parts, tools, materials and test instruments.	<ul style="list-style-type: none"> ◆ manufacturers' brochures (from manufacturers and their representatives) ◆ procurement catalogues from bulk suppliers ◆ lists of the manufacturers registered nationally with the central Ministry of Health. 	For existing equipment and maintenance materials, find as many of these as possible.
Obtain literature from neighbours which, with negotiation, may be available for the cost of photocopying and postage.	<ul style="list-style-type: none"> ◆ copies of manufacturers' operator manuals, service manuals and PPM schedules for older machines ◆ lists of registered manufacturers ◆ sources of spare parts for older machines. 	Contact as many other health facilities and health service provider organizations in your country and neighbouring countries as possible, to obtain existing resources.
Scan single copies of printed documents into a computer and keep them as electronic copies.	<ul style="list-style-type: none"> ◆ user manuals ◆ service manuals ◆ spare parts lists ◆ safety testing procedures ◆ PPM schedules. 	Scan these documents into your computer system and make them more easily available to maintenance technicians at many locations.

Continued opposite

**BOX 7: Strategies For Sourcing Useful Literature and Advice (see Annex 2),
and Expanding Your Library (continued)**

Strategy	Type of Material/Information	Action
Obtain information available internationally which can be paid for as one-off items, or by annual subscription (depending on the material type and source). This material may come as a hard copy or as part of a software package.	<ul style="list-style-type: none"> ◆ text books and reference materials for different technical disciplines (electrical, mechanical, etc) ◆ technical data reference books ◆ manufacturers' operator and service manuals, and spare parts lists ◆ Equipment Hazard Reports and safety literature ◆ PPM schedules and safety testing procedures ◆ technical journals ◆ internationally available advice and guidelines on maintenance, repair, testing, and tools. 	Try to get hold of these resources, perhaps subscribe to them, and look for help to pay for them.
Make sure you order relevant literature when purchasing all your new equipment (see <i>Guide 3</i>).	<ul style="list-style-type: none"> ◆ operator manual ◆ service manual ◆ PPM schedules ◆ safety testing procedures ◆ spare parts list 	<ul style="list-style-type: none"> ◆ when the literature arrives, store the original copies in a safe place (such as the HTMS, facility or workshop library) ◆ make photocopies of the operator manuals, and give one copy to the relevant user department, and one copy to the HTM Team or relevant workshop ◆ make photocopies of the service manuals and other technical data, and give one copy to the HTM Team or relevant workshop.
Investigate other sources for getting literature/ information which you do not have.	<ul style="list-style-type: none"> ◆ suppliers ◆ manufacturers' local representatives ◆ international agencies ◆ links with health facilities abroad. 	Make use of internet (world wide web) contacts where possible, as this method will become more and more important in the future.
If material is no longer available on paper, find a more accessible format.	<ul style="list-style-type: none"> ◆ CD-Rom ◆ video ◆ DVD. 	Investigate these alternative sources of information. Make copies and print-outs of the material and make it available to other facilities.

3.3 PLANNED PREVENTIVE MAINTENANCE (PPM)

Planned preventive maintenance is a series of activities carried out on equipment with the aim of preventing breakdowns and ensuring that equipment is operational and safe. By following a specified schedule of activities according to a given timetable, PPM should reduce the amount of time the equipment is out of service.

PPM is important because it enables the maintenance department to:

- ◆ catch any problems before they become crises
- ◆ prevent breakdowns
- ◆ save money, as PPM is cheaper than repairs following breakdowns
- ◆ make sure that equipment is fully operational
- ◆ guarantee accuracy and reliability (the autoclave sterilizes, the laboratory results are correct, etc)
- ◆ increase the availability of equipment and reduce down-time
- ◆ extend the life-span of equipment
- ◆ reduce equipment running costs
- ◆ ensure the equipment is safe, for patients, users, and maintenance staff.



Experience in Chile

In a Chilean hospital, in-house planned preventive maintenance was introduced and cost monitoring improved (carried out by the existing staff without significant extra cost). Within a year, the expenditure on repairs by external contractors dropped by more than 65 per cent.

Equipment users have a vital role to play in PPM as they will undertake some regular tasks themselves (user PPM). These are primarily activities aimed at ensuring that the performance and functioning of equipment is checked and corrected, as well as the daily cleaning tasks. For further guidance on the user's role in care and cleaning, safety, and maintenance see *Guide 4* on operation and safety.



- Tip**
- Users should only undertake the sorts of procedures that don't require the intervention of technical staff from the HTM Service, and those for which they have been trained. For examples, see *Annex 4*.
 - The changing of chemicals and consumables can **not** become the responsibility of maintenance staff.

Here we concentrate on the PPM work undertaken by maintainers. As discussed in *Section 3.1*, this technical PPM may be undertaken by in-house staff or by external firms under contract. There may currently be very little PPM undertaken by your HTM Team. Thus, it will be necessary to find ways of encouraging staff to carry out PPM and to improve any existing attempts.

You can significantly reduce repair and breakdown problems by implementing a PPM system. Strategies are required to slowly expand how much of your equipment stock receives PPM. *Figure 8* offers some suggestions for the Healthcare Technology Management Service. However, following the suggestions in this figure will require significant resources (people, time, materials, transport, contracts and money).

Many maintenance organizations find that, in practice, they need to shield their staff from normal daily tasks for a period of time to enable them to set up PPM programmes. There is a great deal of paperwork involved if you want the PPM system to work, with its schedules, timetables, planning, and prioritizing, but it is worth the effort. There are a number of computer software systems which can help the HTMS to plan and organize their PPM system – see *Annex 2*.

Figure 8: Strategies for Expanding PPM Coverage by Maintainers Over Time

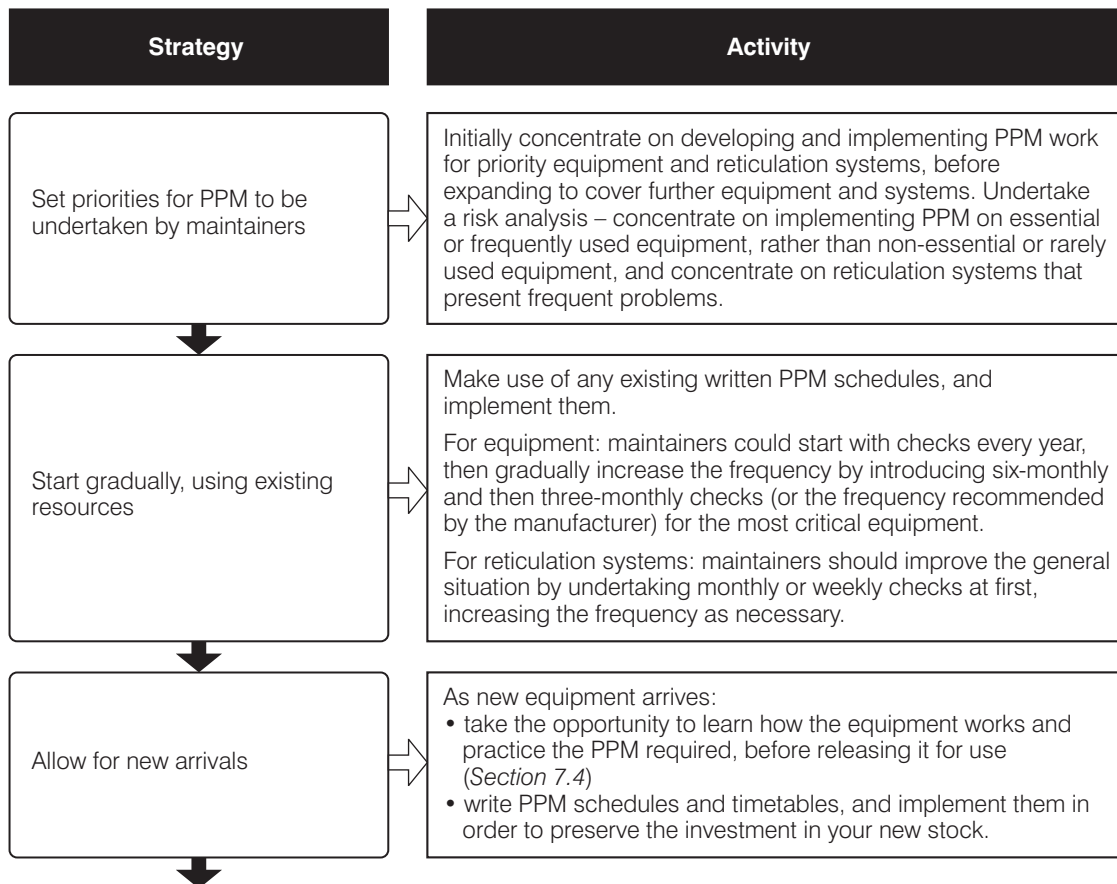

Continued overleaf

Figure 8: Strategies for Expanding PPM Coverage by Maintainers Over Time (continued)

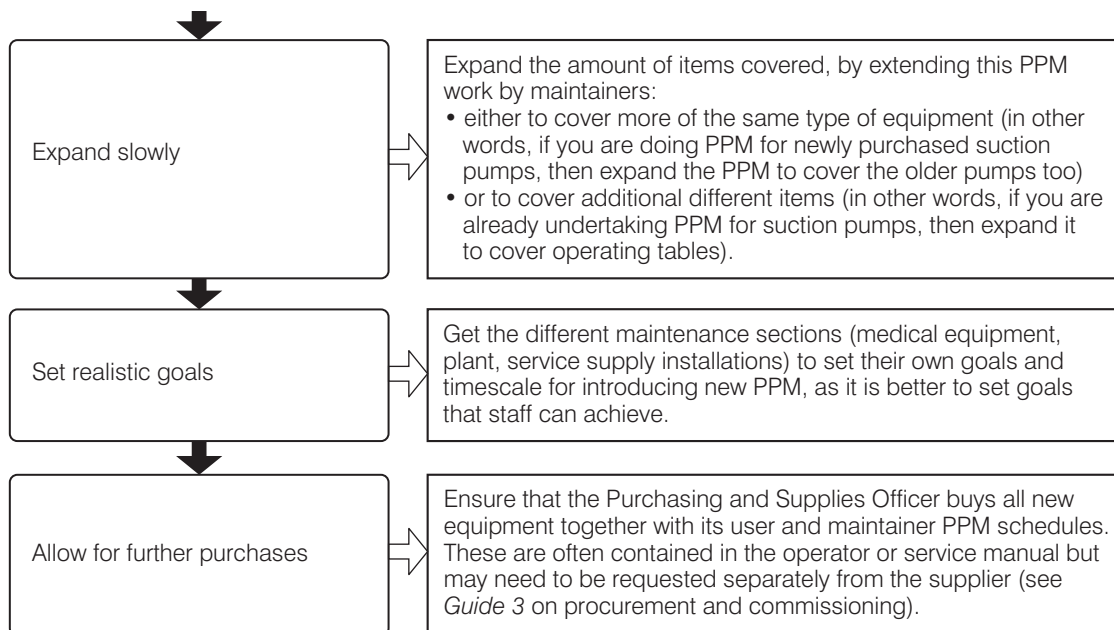

PPM Schedules

PPM consists of a number of tasks of varying technical complexity. Regardless of the complexity of the equipment, there may be three levels of tasks that can be undertaken by different types of staff:

- ◆ The simpler duties – performed by the users of the equipment, if they are adequately trained.
- ◆ The bulk of the work – performed by in-house maintainers with a basic training.
- ◆ More complex work – has to be done by specialized maintenance personnel. This may be in-house maintainers or, in the case of some sophisticated equipment, may involve staff from the manufacturer or service agent under contract.

PPM schedules (protocols, or lists of activities) need to be developed separately for **both** users and maintainers. They should provide simple guidelines for all types of equipment, covering the tasks to be undertaken in the following areas:

- ◆ Care and cleaning.
- ◆ Safety procedures.
- ◆ Functional and performance checks.
- ◆ Maintenance tasks.

These guidelines should include timetables showing the frequency with which the activities must take place.

The best information on equipment PPM is usually contained in the manufacturer's user and/or service manual. However, a wide range of independent material is also available (see *Box 11* and *Annex 2*). Each type of equipment has specific PPM instructions for maintainers. As *Figure 8* explained, maintainers can improve the general situation for pieces of equipment by starting with annual checks and increasing the frequency over time. *Box 8* provides an example of the type of instructions required to be undertaken every six months for infant incubators.

BOX 8: Example of Maintainer PPM Instructions for Infant Incubators

(these may vary or require additions depending on the make and model)

Note: these instructions assume that the equipment users are undertaking the necessary daily PPM tasks (see *Annex 4*).

Every six months

- ◆ Check the physical condition of the power cord, connectors, and plugs.
- ◆ Check the integrity of the electrical grounding of the unit.
- ◆ Check the mechanical integrity of controls and switches.
- ◆ Inspect the condition of the oxygen and air inputs.
- ◆ Check the water level gauge and inspect the distilled-water compartment.
- ◆ Clean or replace the water and air filters.
- ◆ Check the temperature indicator and thermometers, according to the manufacturer's specifications.
- ◆ Check the over-temperature cut-off alarm.
- ◆ Check the power failure alarm.
- ◆ Check the fan failure alarm.
- ◆ Check the operation of the unit. Warm up the unit to a temperature setting on the temperature control, and check the temperature reached with an external thermometer.
- ◆ Check the canopy for any breakages.
- ◆ Clean the inside and outside of the unit, according to the manufacturer's instructions.

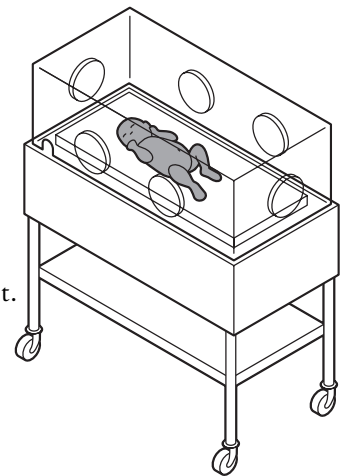

Other types of equipment require maintainer PPM checks at more frequent intervals. *Box 9* provides an example of the type of instructions which should be frequently followed for electrode boilers.

BOX 9: Example of Maintainer PPM Instructions for Electrode Boilers

(these may vary or require additions depending on the make and model)

Note: these instructions assume that the equipment users are undertaking the necessary daily PPM tasks (see *Annex 4*).

Monthly

- ◆ Check the operation of the safety valves.
- ◆ Check the efficiency of the blowdown valve, feed valve, and relief valve.
- ◆ Inspect all joints for leaks.
- ◆ Descale the electrodes, housing, and pipes.
- ◆ Check the spindles, housing, and bleed nozzles.
- ◆ Clean and replace worn pipes.
- ◆ Check the mechanical seal and general operation of the boiler feed pump.

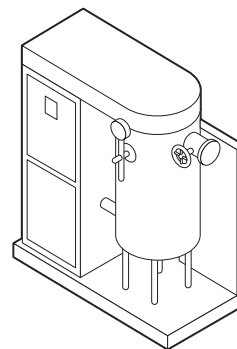

Quarterly

- ◆ Examine the electrics, and clean contacts and flash barriers on the main circuit breaker, pump contactor, and timers.
- ◆ Check the overload settings.
- ◆ Inspect the electrodes. If they are worn down by a maximum of 50mm, fit support rod extensions.
- ◆ Check for erosion of the neutral shield and boiler shell.

In addition, there should be specific maintainer's PPM instructions for each type of service supply installation. As *Figure 8* explained, maintainers can improve the general situation for reticulation systems starting with monthly or weekly checks (which later can be increased to daily checks if necessary), and setting goals that staff feel they can achieve. *Box 10* provides an example of the type of instructions for plumbing installations which maintainers could start with.

BOX 10: Example of Maintainer PPM Instructions for Plumbing Installations When Starting Out

(these are the checks that maintainers could start with, and expand later as required)

Weekly

- ◆ Check the water pipes for leaks.
- ◆ Check taps for leaks (see whether the tap closes).
- ◆ Check the drainage system for blockages.
- ◆ Check cistern flushing systems.

Monthly

- ◆ Check the inlet and outlet pipes of geysers (water heaters).
- ◆ Check the sewage system for the rate of discharge.



Box 11 provides some strategies for expanding your library of PPM schedules, and hence your PPM work.

BOX 11: Strategies for Developing PPM Schedules

Type of Material/Information	Action
PPM schedules and timetables are usually written by the equipment manufacturers, and can be found in their operator or service manuals.	Try to get hold of as many of these as possible (using the strategies presented in <i>Box 7</i>).
Some PPM schedules and timetables have already been developed by international agencies and other sources (see <i>Annex 2</i>).	Try to get hold of these resources (see <i>Box 7</i> for strategies).
All these documents and systems can be modified by technical and clinical staff to suit local conditions.	Meet with your colleagues and draw on your own experiences to adapt the resources to local needs and realities.
Expand the written resources and establish a library of PPM schedules.	The HTMWG's training sub-group (<i>Section 1.2</i>) could be made responsible for this.
Some organizations have developed computer software programs which help with planning PPM. They generate requests for PPM according to timetables, and keep records of the work and results. Some systems also provide generic PPM schedules for different equipment types (see <i>Annex 2</i>).	Investigate this software if your organization wishes to use computerized maintenance systems (<i>Section 4.1</i>).

Another important task for HTM Managers or the training sub-group, is to convert the PPM schedules into some or all of the following:

- ◆ Posters which can be placed on the wall beside the equipment.
- ◆ Paper copies in plastic pockets attached to/hung from the equipment itself (especially for user PPM schedules and care instructions). This is known as an **equipment card** and should be kept permanently with the equipment.
- ◆ Laminated cards, for the technical staff to carry around and refer to when carrying out PPM (especially maintainers' PPM schedules) – see *Section 7.4* and *Figure 23*.

PPM Timetables and Wall Calendars

PPM work must be carried out at specified intervals, as detailed in the schedules. The HTM Managers and Heads of User Departments should liaise to draw up timetables to ensure that the PPM work is undertaken at the required frequency. Some tasks need to be undertaken daily, others weekly, monthly, or quarterly, and so on. If your Healthcare Technology Management Service has a computerized maintenance management system (*Section 4.1*), this can automatically generate work orders when the PPM is required.

3.3 Planned preventive maintenance (PPM)

The simplest form of timetable is to have a monthly duty list. Alternatively, it is useful to display the planned work on wall calendars indicating when PPM should be carried out. The calendar should incorporate space where staff can sign off and date when they finish the task, to show that each timetabled PPM activity has taken place. This method provides staff with a visual display of their progress with planned work, and a record for managers to monitor. An example is shown in *Figure 9*.

In addition, it is possible to use stickers on equipment showing the next service due date or to enter this information on the equipment card. Equipment users can inform their Head of Section if the date is near or expired.

It is also important to keep a record of any pieces of equipment that are substituted. If your equipment has been labelled with some form of inventory code number (see *Guide 2* on planning and budgeting), it will be easier to tell which particular piece of equipment you have been maintaining.

Figure 9: Example Timetable of PPM for Maintainers in Wall Calendar Format

PPM Wall Calendar Timetable												
Months	J	F	M	A	M	J	J	A	S	O	N	D
Suction Machine			PH b						PH b			
Infant Incubator		PH b						PH b				
Autoclave	PH b			PH q			PH b			PH q		
Electrode Boiler	DT m	DT q	DT m	DT m	DT q	DT m	DT m	DT q	DT m	DT m	DT q	DT m
Plumbing Installations	EB m	EB m	EB m	EB m	EB m	EB m	EB m	EB m	EB m	EB m	EB m	EB m
Key: b = 6-monthly (bi-annual) q = 3 monthly (quarterly) m = monthly												

3.4 SAFETY AND CALIBRATION TESTING

Equipment should be in an acceptable physical and working condition at all times, so that it can perform competently and safely. Equipment should not be allowed to deteriorate to such an extent that it becomes untrustworthy or hazardous.

For example:

- ◆ frayed mains leads
- ◆ disconnected earth
- ◆ metal with stress fractures
- ◆ leaking gas valves
- ◆ cracked glass
- ◆ failing brakes
- ◆ perished rubber materials.

One strategy is for all staff to regularly check equipment visually for such disintegration, and to report any findings to the HTM Team. However, to reduce the risk of such problems, regular testing for electrical and mechanical trustworthiness, using test instruments, is required. Such testing is known as safety testing, and ensures the safety of equipment.

Another strategy is for all staff to monitor whether equipment is performing as it should be (for example, that an incubator reaches a set temperature, that an autoclave sterilizes its contents, that an X-ray machine produces diagnostic quality X-ray images) – although this is not always obvious. The equipment should then be calibrated to adjust its performance and return it to a set standard. Calibration can sometimes be undertaken by the equipment users, and sometimes requires the HTM Team.

Safety and calibration instruments (see page 57) are required to enable this process to take place. Safety and calibration testing usually takes place regularly throughout the life of the equipment:

- ◆ During the acceptance process when equipment first arrives (see *Guide 3* on procurement and commissioning).
- ◆ Whenever staff suspect that there may be a problem, or the equipment may not be performing properly.
- ◆ Regularly as part of the usual planned preventive maintenance tasks (*Section 3.3*).
- ◆ At the end of every repair and corrective maintenance task, whenever equipment breaks down (*Section 3.2*).

Testing is required for various types of hazard, which are presented by different types of equipment. (See *Guide 4* on operation and safety for a fuller description of the hazards presented by equipment). For example:

- ◆ gas installations need to be tested for gas leaks
- ◆ mechanical tests are required to ensure that equipment can withstand its operating conditions such as any pressure, hydraulic, rotation, or heat stresses, and will not break down and create a hazard
- ◆ physical checks are required to ensure, for example, that safety guards are replaced on engines so that clothing cannot get caught in machinery
- ◆ electrical tests are required for electrical hazards – the major category of hazard – due to electrical installations, earthing, and medical equipment.

Electrical Installations and Earthing

Human bodies are electrical conductors. The passage of electrical current through the body can cause burns or severe muscle cramps, and if electricity flows through the heart it can cause irregular heartbeats and death. Thus obtaining a good quality electrical installation with proper earthing is essential (see *Guide 4* on operation and safety).

The electrical installation must be regularly inspected and tested by electricians, using the correct test instruments (see *Box 12*). To guarantee the safety of installations, they need to:

- ◆ test for earth leakage
- ◆ test for circuit continuity
- ◆ test for loose connections
- ◆ perform insulation tests
- ◆ test switch leakages
- ◆ test for power
- ◆ check for the correct rating
- ◆ check whether wiring regulations were followed during installation.

Medical Electrical Safety

Another important area of safety is medical electrical safety. Medical electrical equipment has stricter electrical safety requirements and considerations than non-medical equipment, because it comes into direct contact with patients (for example, ECG recorders, monitors, diathermy units, and physiotherapy ultrasound).

All such equipment should conform to (and be manufactured to) the international safety standard IEC 60101 (see *Guide 3* on procurement and commissioning). It describes electro-medical equipment according to the **type** of protection provided against electric shock (defined as Class I, II, or III), and the **degree** of protection provided against electric shock (defined as Type B, BF, or CF). You can tell which sort of equipment you have by studying the symbols on the manufacturer's label attached to your equipment.

Such equipment will require dedicated safety testing procedures and test instruments, which go further than the standard electrical safety tests described above. All electro-medical equipment should be regularly inspected and tested by bio-medical technicians, using the correct test instruments (see *Box 12* below).

To guarantee safety, they should perform a variety of tests on each piece of equipment depending on its Class and Type (see *Annex 2*), such as:

- ◆ self-checks
- ◆ supply voltage check
- ◆ insulation resistance test
- ◆ earth bonding test
- ◆ earth leakage current test
- ◆ enclosure leakage current test
- ◆ patient leakage current test
- ◆ patient auxiliary current test
- ◆ mains voltage on the applied part test.

Safety and Calibration Testing Instruments

Safety and calibration testing should be encouraged, even though some of the instruments required are expensive. Most test instruments are used for electrical, electronic, or medical equipment purposes. Since medical equipment has stricter electrical safety requirements and considerations than non-medical equipment, it requires dedicated safety test instruments which go further than simple electrical safety testers.

Thus, the HTM Team requires adequate test instruments. Some instruments provide basic tests, while others are designed for more complex procedures.

Box 12 provides some advice on the types of test instruments required, which are bench-top instruments. Not every HTM Team or workshop needs all of them: it will depend on the skill levels of the staff. However, anyone maintaining or repairing medical equipment needs some form of medical equipment safety tester – either a basic one made from common bench tools or a commercially available product for comprehensive testing (see *Box 12*). Other smaller hand tools used for testing purposes are included in the regular tool kits for maintenance staff – see *Section 5.1* and *Annex 6*.

Figure 10 overleaf offers some suggestions for increasing safety and calibration testing. However, we recognize that following the suggestions in this figure will require significant resources (money, people, time).

BOX 12: Example of Safety and Calibration Testing Instruments by Type of Work and Skill Level

Type of work	Instrument	Skill level
Electrical	insulation tester ('megger' meter) mains socket wiring tester phase tester	Basic
	continuity tester three-phase tester	Specialist
Electronic	multimeter	Basic
	bench-top power supply counter/timer function generator oscilloscope	Specialist
Medical equipment	ammeter and earth break box (instead of MES tester) electronic thermometer standard mercury BP apparatus	Basic
	defibrillator analyzer/tester ECG simulator electro-surgical unit (ESU) analyzer medical electrical safety (MES) tester/analyzer ^{1,2} non-invasive BP monitor tester oxygen analyzer oxygen flow meter monitor patient simulator, multi-parameter, two-channel pH meter standards phosphorescent strip pressure/vacuum meter spectrophotometer standards X-ray line resistance meter X-ray mAs meter X-ray phantoms	Specialist
	gas analyzer ultrasound therapy unit output (precision) test balance ventilator tester	Advanced specialist – very expensive and only required in the largest workshops
<p>Note:</p> <p>1. The medical electrical safety (MES) tester/analyzer should include an IEC 60101-1 test load</p> <p>2. A portable appliance tester (PAT) could possibly be used instead of an MES – something is better than nothing. However, it cannot necessarily go down to the correct sensitivity for medical equipment or check for patient probe leakage. Use of a PAT requires specialist advice in order to be aware of its limitations.</p>		

Figure 10: Strategies for Safety and Calibration Testing

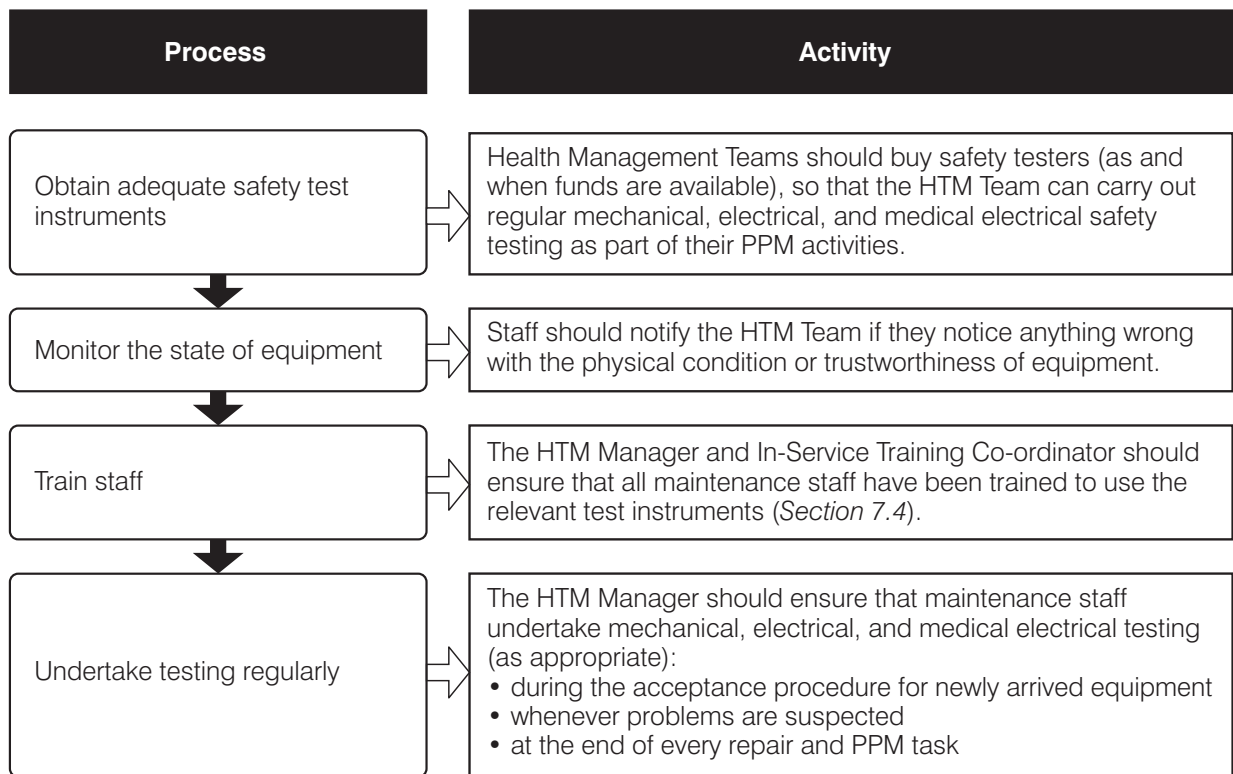

3.5 SITE AND CONTRACT MANAGEMENT

There will be instances when the in-house team can't undertake repair, PPM, or safety testing work, and support is required from external maintenance contractors. One source is private commercial companies who are important partners for health services. They may offer a range of services, such as the sale of consumables (for example, reagents and spare parts), difficult repairs, and consultancy and training services. Additional sources of support are other private operators, other government workshops, and agencies in the non-governmental sector. *Box 13* provides a summary of these external sources of support which you can investigate.



Experience in Africa

In Cameroon, government health facilities pay maintenance teams from faith-based health facilities to service their equipment.

In Tanzania, the Christian Social Services Commission supports three zonal health care technical workshops. Hospitals in each zone are members of the workshops. The workshops also offer their services to non-members, for instance to train technicians from government hospitals which are not yet members.

BOX 13: Potential External Sources of Maintenance Support

Source	Example
Individual tradespeople	Plumbers, electricians, carpenters, etc.
Specialized firms	Lathe works, motor winding enterprises, etc.
Equipment companies	Manufacturers, and agents or representatives of the manufacturer, either based locally or in neighbouring countries.
Other private firms	Garages, laboratories, airline workshops, etc.
National supply authorities	Those responsible for electricity and water supply and telecommunications. (In your country there may be equipment under the control of these agencies which you must not interfere with, such as electricity transformers, incoming mains water pipes, or telephone switchboards).
Government workshops, traditionally involved with the health service equipment stock	Those run by the ministries of Works, Supplies, or Transport. (In your country, these ministries may already be responsible for different parts of your equipment stock such as buildings, plant, service installations, furniture, and vehicles).
Skills available in other government workshops	Those run by ministries such as agriculture, defence, higher education, etc.
Training institutes	Such as vocational training workshops.
Non-governmental organizations	Workshops run by NGO health service providers, such as church hospitals and mine hospitals.

**Experience in Southern Africa**

A district hospital wished to have its new dental suite installed. Because different maintenance agencies had responsibility for certain types of healthcare technology, this task involved many people:

- ◆ *a builder (to make trenches in the concrete floor and make good afterwards) from the Ministry of Works' building maintenance workshop in a nearby town*
- ◆ *a plumber (to connect the water and waste pipelines) from the Ministry of Works' building maintenance workshop in a nearby town*
- ◆ *an electrician (to connect the compressor to the mains supply) from the Ministry of Works' electrical maintenance workshop many miles away*
- ◆ *a medical equipment technician (to make all other connections and oversee the job) from the health service provider's maintenance workshop in the region's capital.*

Unfortunately, not only was it very difficult to arrange for these four people to attend to the job, it was impossible to get them there at the same time. One person would turn up to do his job, only to find that the other people he needed to complete his task were not there. Another would turn up to find that he could not work because other tasks had not been completed. After months of arguing, the installation had still not taken place.

Site Management

If you have an array of maintenance agencies providing support, one important issue for HTM Managers is how to supervise the different staff while they work on the health facility site.

Ideally, the health service provider should have overall management control of all of its equipment, but we recognize that, in reality, it can be hard to coordinate and control staff from other maintenance agencies.

It is essential that the HTM Manager based at the health facility knows who will be working on site. He or she is then responsible for informing the health management team and senior staff in the equipment user department. If the external maintenance support has been organized by a referral workshop higher up the HTM Service network, its staff must inform the health facility's HTM Manager of any planned visits.

Individual maintainers should always make it their business to report to the Section Head in the user department:

- ◆ when arriving to start a job
- ◆ when leaving with the job still unfinished
- ◆ when the job is complete.

The importance of such reporting and feedback is discussed further in *Section 7.2*.

It is essential that maintenance staff understand the specific protocols involved in working at a health facility site, in order to protect the working environment, the privacy of patients, and the safety of all. One example is that maintainers cannot simply walk into an operating theatre complex in their boots and overalls, they can only enter when operating staff say so, to areas not in use, and wearing suitable protective surgical clothing.

There are many other examples of how maintainers should behave either due to the nature of the specific area within the health facility, because patients are present, or because treatment is under way. Such issues must be covered by the induction training given to in-house maintenance staff (*Section 7.4*). In-house maintainers with this knowledge should then accompany staff from external maintenance agencies to ensure they conform to the health facility protocols (see below).

Contract Management

Contract management
the process by which people
or companies who sell
maintenance services
will be hired and supervised.

We suggest that any person or company who wishes to be considered as a supplier of maintenance services, should be registered with the 'client' – that is either the health facility, workshop, or health service provider (depending on national guidelines and the size of the job).

The person/company should be made to go through a registration process, which ensures the following:

- ◆ The profile of each person/company is verified (in other words, whether they have a workshop, technical staff with appropriate skills, transport, materials, cash flow, etc).
- ◆ Payment is straightforward. Without registration the client cannot pay the person/company for services (unless some prior arrangement has been made).
- ◆ A quick response is obtained from the registered person/company. Without registration the maintenance provider may not feel the need to respond quickly to requests for help.
- ◆ Corruption is less likely to occur (for example, official registration avoids the inappropriate hiring of relatives of staff members).



Experiences in Africa

Good sources of support:

- ◆ *An international company supplied imaging and radiology equipment, and a five-year maintenance contract was agreed. Because of this contract, the company trained local technicians to manage the contract and it worked well.*

Bad sources of support:

- ◆ *Some international manufacturers nominated (from a distance) local companies to be their representatives for providing maintenance support. But when the local maintenance staff went to investigate them, they found they had no workshops or even technical staff.*
- ◆ *A hospital wanted a local tradesperson (artisan) to help them with the problems they were having with their electrode boiler, so they hired a local electrician. However, he had no knowledge of the boiler and got it working again by bypassing all the electrical safety features, and both the boiler and boiler house burnt down.*

A team of suitable staff should be sent to inspect individuals or companies applying to be registered as a supplier of services. Sending a team is best, as it ensures that too much decision-making power is not given to one individual. Registration is usually undertaken by a team of the Purchasing and Supplies Officer, the HTM Manager, and a number of other officers. They should do the following:

- ◆ Inspect the individual's or company's premises and verify their capacity to provide the services offered.
- ◆ If a physical visit is not possible, attempt to investigate the profile of the person or company.
- ◆ Use a standard pre-qualification form which records relevant information as well as the results of any inspection undertaken (see *Guide 3* for assistance).
- ◆ Report back to the health service provider and only register the person/company as a supplier of the agreed services when it is satisfied.

Once people or companies have been identified and registered, there are four typical types of arrangement under which they can be called upon to provide maintenance services to health service providers. *Box 14* provides a description of how the different arrangements work.

The arrangement used depends on the sophistication of the equipment, the type of support required, the number of external support choices available, and the ease with which you can enter into contracts. *Box 14* assumes that the HTMS is trying to organize a rational approach to using contracts. This may involve centrally organizing the contracts in order to:

- ◆ conform to any equipment supplier's warranty or purchase contract conditions
- ◆ gain the benefits of bulk buying (in other words, contracting a company to cover many similar items)
- ◆ gain the benefits of fixed-period contracts (for example, contracting a company to assist you for one year)
- ◆ make use of a formal tender process
- ◆ ensure the appropriate choice of contractors
- ◆ protect the quality of the work.

BOX 14: Types of Arrangements for External Parties to Provide Maintenance Services

Type of Arrangement	How it Works
<p>Agents' Maintenance Contracts Particular items of sophisticated equipment have service agents nominated by the manufacturer (such as X-ray machines or laboratory analyzers).</p>	<p>The manufacturer or service agent provides maintenance support for the warranty period at the company's cost. A post warranty contract can be agreed. This is best done at the time of purchase (see <i>Guide 3</i>). The agent should quote for the cost of servicing for a year. The terms vary depending on the firm, the equipment, distance to travel, etc. The contract usually includes fixed costs (such as labour charges), and variable costs which have to be paid for in addition to the quote (possibly the spare parts used and transport charges).</p> <p>It is important that the contract details the response time or the guaranteed time to get the equipment running once it has failed. A penalty should be specified in case this time is not met. The client enters into and signs the fixed annual maintenance contract with the service agent. Then, when their support is required, they can be called in straight away.</p>

Continued overleaf

**BOX 14: Types of Arrangements for External Parties to Provide Maintenance Services
(continued)**

Type of Arrangement	How it Works
<p>Annual Contracts to Supply Services For particular types of equipment or groups of equipment types (such as anaesthetic machines or lifts), the client may advertise for companies to provide specific services for a year.</p>	<p>Companies tender in advance to supply services for the coming year. Whoever wins the contract must supply those services throughout the year at the price quoted. The terms vary depending on the firm, the equipment, distance to travel, etc. The contract usually includes fixed costs (such as labour charges), and variable costs which have to be paid for in addition to the quote (possibly the spare parts used and transport charges).</p> <p>It is important that the contract details the response time or the guaranteed time to get the equipment running once it has failed. If this time is not met, a penalty should be specified. The client enters into and signs the fixed annual maintenance contract with the service supplier. Then when their support is required, they can be called in straight away.</p>
<p>Annual Standby Registration There may be several individuals or companies who can provide maintenance services for the same types of equipment (generators or vehicles, for example).</p>	<p>Once these companies are registered, they are considered available to be called upon during the following year to provide maintenance support when it is required, but they cannot be called in immediately. As there is no guarantee that their services will be needed, they will be asked to quote/compete for tenders along with others on the list only when a relevant job comes up. Every year the registration will be reviewed before it is renewed.</p>
<p>One-off Jobs These are required for certain types of new equipment not yet on a contract list, other types for which there are no possible registered contractors as no skills are available in the country, and relatively simple jobs which only need occasional local assistance (use of builders, electricians, etc).</p>	<p>The client must make an effort to search for individuals/companies to register. However, in an emergency, the client tries to get three quotes, and may enter into a one-job contract without registration (and possibly without a tender process). The individual/company chosen will be called in on a one-time basis only.</p>

Entering into any contract requires the Purchasing and Supplies Officer and the HTM Manager to draw up a description of the work to be covered. It is usual in most organizations to obtain at least three quotes and/or go out to tender in order to select the winning individual/company, with advice from the HTMS (see *Guide 3* on procurement and commissioning).

All HTM Managers and Health Management Teams in your organization should be supplied with the list of centrally-arranged registered contractors and annual contracts, to conform to. However, if health facilities have the autonomy and authority required to do so, they might make their own local arrangements with individuals/companies occasionally, especially for the simpler jobs. In this situation, they should still register suitable individuals/companies, to try to avoid poor service and damage to the equipment.

When HTM Managers identify repair, PPM, and safety testing tasks that cannot be carried out by the in-house team, they refer to existing registers and contracts, and:

- ◆ either call an individual/company directly if an annual contract exists, or obtain at least three quotes
- ◆ submit a requisition to the Purchasing and Supplies Officer, who will notify the winning individual/company to move onto site
- ◆ liaise with the Finance Officer to pay under contract terms, when successful completion has been verified.

In-house maintainers should be made available to accompany external contractors whenever possible, both to learn from them and also to monitor the work taking place. (In-house staff will also ensure that the external contractor conforms to the protocols of working at the health facility site, as discussed earlier).

The HTM Team should keep some form of Contractors' Record Book or File in which they record details of the contractor which undertook the job and their performance (*Section 4.3*). It is imperative that in any contract, the terms of payment are linked to satisfactory completion of the work and an official handover.

It is a good idea to create a list of individuals/companies that are banned due to previous poor performance. Each year the Purchasing and Supplies Officer, together with the HTM Manager, should undertake a review to:

- ◆ evaluate the performance of the individuals/companies used
- ◆ ask the individuals/companies offering annual contracts to provide quotes for the coming year
- ◆ review the registrations of the individuals/companies on standby
- ◆ attempt to identify individuals/companies to register for the equipment types where one-off contracts had been placed (because no relevant company had been registered previously).

3.6 MANAGING OUTREACH WORK

Maintenance outreach travelling from one base to undertake maintenance work at many different locations.

In the HTM Service, HTM Teams are based at health facilities. However, additional maintenance staff (with more skills) are based at district, regional, and central workshops so that they can offer support to the service as a whole. Best use is made of their skills (especially if there is a shortage of staff), and other resources, if they are concentrated in a few locations, travel to different jobs, and are kept busy using their expertise for lots of different clients (health facilities). Such outreach work should also be used by senior staff to provide support and supervision to the HTM Teams within the HTM Service (*Section 7.2*).

In some countries, HTMS staff have to undertake maintenance work over vast distances, through difficult terrain, cover many clients during round-trip journeys, and be away for extended periods. The travelling is sometimes undertaken using the HTM service's motorbikes, cars, vans, and mobile workshops, or by making use of local buses, boats, and planes.



Country Experience

Outreach work is undertaken in different ways in different places:

- ◆ *In Papua New Guinea, the maintenance service of the faith-based health service provider makes use of motorboats around the coastline.*
- ◆ *In Malaysia, the government maintenance service flies to different parts of the country which are isolated.*
- ◆ *In Zambia, staff from the central government workshop use local bus services to reach rural provinces.*
- ◆ *In some regions of Namibia, mobile workshops are used to cover large remote areas.*

The most frustrating situation is for the outreach team to turn up and find they have the wrong parts and tools and cannot finish the job. Thus good communication, reporting, and planning are required. Your ability to undertake outreach successfully will depend on whether:

- ◆ the maintenance visit is going to be part of a regular programme or is a one-off job
- ◆ your team has the right technical skills required
- ◆ enough staff are available, and some can be absent from their base workshop
- ◆ transport and suitable drivers are available
- ◆ tools and materials are available, and can be taken away from the base workshop
- ◆ subsistence allowances are available for staff who stay for nights away from their base.

HTM Teams at health facilities may be given outreach responsibilities by the HTMS for smaller facilities in the surrounding area, just as health staff undertake clinical outreach work. Thus Health Management Teams must enable their HTM Team to do this outreach work, rather than consider that the maintainers are only available for their facility/area. This means that Health Management Teams must give the maintainers access to the transport pool, material resources, and relevant budgets. Otherwise, the work undertaken by outreach (such as PPM) will have to be financed centrally to ensure it takes place.



Experience in a West African Country

The government HTMS had set up regional workshops based at regional hospitals to care for equipment in the region. The budgets for maintenance were decentralized to the regional health authorities. When money was short, the importance of continuous maintenance support was not fully recognized. The regional authorities stopped the money, transport, and support for workshop staff to undertake any journeys away from their base, leaving the rest of the region with no maintenance assistance.

It turned out that decentralization of the financial control of maintenance had been premature. In response, the Ministry of Health later chose instead to 'ring-fence' money centrally for outreach work, in order to ensure that it took place.

Box 15 contains a summary of the issues covered in this Section.

BOX 15: Summary of Procedures in Section 3 on Work Planning

Priorities	Health Service Provider	<ul style="list-style-type: none"> ◆ finances sufficient resources of all kinds for the HTM Service (materials, funds, training, etc) ◆ employs a range of multi-disciplinary staff with mixed skill levels for the HTMS
	HTM Managers collectively (from all levels of the HTMS)	<ul style="list-style-type: none"> ◆ plan: <ul style="list-style-type: none"> - which sort of maintenance staff (according to type and level of skill) can undertake which type of repairs and maintenance - when to use the in-house teams and when to use external contracts - the priorities for a PPM system, and determine what should be done by users and what by maintainers - the outreach system ◆ draw up the external maintenance contracts ◆ set up a fault-reporting system (<i>Section 4.2</i>)

Continued overleaf

BOX 15: Summary of Procedures in Section 3 on Work Planning (continued)

Repairs	Health Management Teams	<ul style="list-style-type: none"> ◆ allocate the HTM Teams with sufficient resources of all kinds (materials, funds, training, etc)
	Equipment Users and Managers	<ul style="list-style-type: none"> ◆ report faults and breakdowns promptly according to the fault-reporting system (<i>Section 4.2</i>) ◆ report any problems with the actions of maintenance staff or external contractors to the HTMS
	HTM Managers	<ul style="list-style-type: none"> ◆ develop a technical library (<i>see Box 7</i>) ◆ ensure the tools and materials the HTM Team require are available (<i>Sections 5 and 6</i>) ◆ allocate the jobs to suitable maintenance staff or call in the relevant contractor ◆ monitor that the maintenance staff use the correct repair techniques, and report any problems to the Health Management Team or HTMS in order to trigger training interventions (<i>Section 7</i>) ◆ monitor the work of external contractors to ensure effective and efficient repair of equipment according to the contract (<i>Section 3.5</i>)
	HTM Teams (specifically maintenance staff)	<ul style="list-style-type: none"> ◆ respond to maintenance requests promptly ◆ provide feedback to the users on progress (<i>Section 7.2</i>) ◆ know the correct basic operating techniques and relevant safety issues of the equipment they maintain (<i>see Guide 4</i>) as well as the correct repair techniques, and ask for help and training if unsure ◆ follow good practice fault-finding strategies (<i>see Figure 7</i>), and manuals and training materials (<i>Section 7.4</i>) to avoid damaging the equipment ◆ avoid creating hazards and obstacles while working ◆ keep a record of their maintenance work (<i>Section 4</i>) to help other staff if a similar breakdown occurs again ◆ report any problems with user operation or handling of equipment to section heads and Health Management Teams

Continued opposite

BOX 15: Summary of Procedures in Section 3 on Work Planning (continued)

PPM	Health Management Teams	<ul style="list-style-type: none"> ◆ allocate the HTM Teams with sufficient resources of all kinds (materials, funds, training, etc)
	HTM Managers	<ul style="list-style-type: none"> ◆ prepare maintainers' PPM timetables, display wall calendars in the workshop/maintenance room, and provide staff with laminated PPM schedules (<i>Section 7.4</i>) ◆ ensure their teams implement the maintainers' PPM, and monitor their progress ◆ liaise with equipment user departments to develop the user PPM system (see <i>Guide 4</i>) ◆ contract and monitor external agencies to undertake PPM for sophisticated equipment (<i>Section 3.5</i>) ◆ continue to expand PPM work, by following the strategies detailed in <i>Figure 8</i> and <i>Box 11</i>
	HTM Teams (specifically maintenance staff)	<ul style="list-style-type: none"> ◆ carry and refer to the laminated cards showing PPM schedules ◆ fill in the necessary written records (<i>Section 4.3</i>) ◆ sign off and date the work in the space available on the wall calendar, when the job is completed
	Equipment Users and Heads of Department	<ul style="list-style-type: none"> ◆ work with the HTMS to prepare a user PPM system (see <i>Guide 4</i>) ◆ prepare user PPM timetables, wall calendars, and laminated PPM schedules, with advice from the HTMS ◆ expand PPM work, by following the strategies detailed in <i>Figure 8</i>, <i>Box 11</i> and <i>Annex 4</i>
Safety Testing	Health Service Provider	<ul style="list-style-type: none"> ◆ plan and budget for adequate safety and calibration testing instruments (see <i>Box 12</i>)
	HTM Managers and Teams	<ul style="list-style-type: none"> ◆ undertake safety and calibration testing: <ul style="list-style-type: none"> - when equipment first arrives - as a part of PPM tasks, and - at the end of every repair and corrective maintenance task

Continued overleaf

BOX 15: Summary of Procedures in Section 3 on Work Planning (continued)

Site and Contracts	Healthcare Technology Management Service	<ul style="list-style-type: none"> ◆ decides which equipment should fall under centrally-arranged contracts, and organizes them ◆ supplies Health Management Teams and HTM Teams with the details of the centrally-arranged contracts and lists of registered individuals/companies ◆ negotiates with the different maintenance agencies for better coordination on site
	Health Management Teams	<ul style="list-style-type: none"> ◆ conform to any centrally arranged contracts and registered lists ◆ make funds available for the necessary support from maintenance contractors
	Purchasing and Supplies Officers	<ul style="list-style-type: none"> ◆ together with the HTM Manager: <ul style="list-style-type: none"> - use a team of people to verify and register local individuals/companies who will be asked to provide maintenance services - use a three quote or tender process to select the individual/company to provide support - notify the winning individual/company to move onto site, on receipt of a requisition for the work - review the contracts and registered lists each year
	HTM Managers	<ul style="list-style-type: none"> ◆ identify repair, PPM, and safety testing tasks that can't be carried out by the in-house team ◆ refer to existing registers and contracts, and either call an individual/company directly if an annual contract exists, or obtain at least three quotes ◆ submit a requisition to the Purchasing and Supplies Officer, and liaise with the Finance Officer to pay under contract terms ◆ ensure a member of the in-house HTM Team accompanies the contractor, and fills in the Contractors' Record Book/File (<i>Section 4.3</i>) ◆ verify the technical report submitted by the contracted individual/company ◆ notify the Health Management Team and senior staff in the equipment user department when external maintenance personnel will be working on site ◆ coordinate the work of staff from different maintenance agencies
	Finance Officers	<ul style="list-style-type: none"> ◆ make payments against the contract, once the work has been done to the facility's and HTM Manager's satisfaction (unless it is free of charge under warranty terms)
Outreach	Health Management Teams	<ul style="list-style-type: none"> ◆ recognize the outreach role that the HTM Team based with them might have to carry out ◆ provide access to the transport pool, subsistence allowances, etc
	HTM Managers (at all levels of the HTMS)	<ul style="list-style-type: none"> ◆ plan what type of outreach work should be carried out by which HTM Teams ◆ provide support and supervision to maintenance staff by outreach
	HTM Teams (specifically maintenance staff)	<ul style="list-style-type: none"> ◆ take care of the equipment in health facilities in their catchment area, by outreach

4. HOW TO KEEP A RECORD OF MAINTENANCE WORK

Why is This Important?

In order to manage your equipment effectively, you need information about it – it is very difficult to manage an unknown.

You need to have records of what things were like in the past, so that it is possible to see if things are getting better and learn from past actions.

Finally, keeping maintenance records provides the HTM Team with valuable information and proof that they can use to ask for help and argue for more resources.

To be effective, keeping a record of maintenance work needs to comprise several components and cover several activities. In this Section, the requirements are discussed through the following issues:

- ◆ An overview (*Section 4.1*).
- ◆ Fault reporting and monitoring completion (*Section 4.2*).
- ◆ Monitoring team progress and recording work undertaken (*Section 4.3*).
- ◆ Service history files (*Section 4.4*).

4.1 OVERVIEW

A **Maintenance Record System** helps the health service to keep track of the maintenance and repair work done. It provides the health service with important information regarding:

- ◆ how many jobs are being done at any one time
- ◆ how many jobs are still waiting to be started
- ◆ how the jobs are allocated to HTM Team members, and therefore who is overworked
- ◆ the details of the work done on each machine, and therefore what the history of the machine is
- ◆ what spare parts and materials are used, and therefore which stocks need to be replaced
- ◆ when a job is completed
- ◆ what the causes for delays are, and therefore what resources are needed to finish the work
- ◆ how busy the HTM Team is, and therefore how best to plan its work
- ◆ which jobs are still outstanding, and therefore how to prioritize the next week's work.

With this information, it is possible to compile further data which will help the health service to find out the following sorts of information:

- ◆ The common problems for individual machines.
- ◆ The spare parts most frequently used.
- ◆ How busy each HTM Team is – for example, how many jobs are done in a month.
- ◆ How long jobs take to complete.
- ◆ The common causes of delay – for example, a shortage of spare parts, skills, money, transport, etc.
- ◆ The service history of individual machines.
- ◆ Where most problems are in each facility/district.
- ◆ What maintenance work the HTM Team is capable of.
- ◆ The work input of each member of the HTM Team.
- ◆ The duration of equipment down-time.

The basis of every maintenance record system should be the Equipment Inventory. This planning ‘tool’ is a manual or computerized listing of key details of the equipment that you currently own. Such information is vital for maintenance staff if they are to care for the equipment stock.

Did you know?

Knowing what you own means:

knowing	-	what there is	<i>type/sorts</i>
	-	how much of it there is	<i>quantity</i>
	-	where it is	<i>location</i>
	-	what condition it is in	<i>status</i>
	-	how far it is in its lifecycle	<i>age/expected life</i>
having	-	some way of updating the information	<i>accuracy</i>

The method for doing this is to keep an **inventory** of your equipment.

The inventory listing should have ‘inventory code numbers’, so that the record for each individual machine can be identified. The HTM Service then labels each separate piece of equipment with its inventory code number, to identify it among many similar items. Any maintenance record system should be linked to the inventory code numbers. A description of how to set up an equipment inventory and a code-numbering system is provided in *Guide 2* on planning and budgeting.

When taking the annual inventory, the inventory record sheet will gather particular equipment details. However, HTM Teams will require additional information concerning the equipment, and this should be recorded in its Service History (*Section 4.4*). This record can be started at any time, but it is useful to gather such information during the Acceptance Testing Process when equipment first arrives (see *Guide 3* on procurement and commissioning). *Box 16* shows the types of information kept in both places.

BOX 16: Data to Store for Each Piece of Equipment

Information gathered on the equipment inventory record sheet (see <i>Guide 2</i>)	Additional information to keep – usually in the service history file (<i>Section 4.4</i>)
<ul style="list-style-type: none"> ◆ date inventory taken ◆ facility, department, section, and location/room ◆ type of equipment ◆ inventory code number (your own number) ◆ name of manufacturer ◆ model name and/or number ◆ manufacturer’s serial number (factory number) ◆ year made or bought ◆ supplier bought from ◆ status/condition ◆ your property or leased 	<ul style="list-style-type: none"> ◆ address of the manufacturer and local agents ◆ address of the supplier and local representative ◆ technical ratings ◆ date when the warranty expires ◆ price paid ◆ any external funding agency involved ◆ stocks of consumables, accessories, and spare parts received ◆ results of inspection tests undertaken on commissioning ◆ frequency of planned preventive maintenance required ◆ details of any maintenance contract and maintenance contractor ◆ maintenance history

A maintenance record system needs to be established for every HTM Team (whether based at a workshop or not). The development of such a system will be an ongoing process and will occur in stages over time. The components of such a system are:

1. a method of fault-reporting and monitoring completion
2. a method of monitoring team progress and recording the work undertaken
3. keeping equipment service histories.

The rest of this Section describes these three aspects of the record-keeping process. However, the information in the maintenance record system is also used for other purposes, and these are described elsewhere in this Guide or Series of Guides as follows:

- ◆ Weekly work planning (*Sections 3.1 and 7.2*).
- ◆ Registering the allocation and condition of tools (*Section 5*).
- ◆ Keeping track of the use of spare parts and maintenance materials (*Section 6*).
- ◆ Feedback and reporting to management (*Section 7.2*).
- ◆ Staff work records (*Section 7.3*).
- ◆ Annual action planning (*Section 8.1*).
- ◆ Statistics and information for management (*Section 8.2*).
- ◆ Costing the work undertaken (see *Guides 2 and 6*).
- ◆ Planning the development of the equipment stock (see *Guide 2*).

These different components of the record system all interlink to form an overall record-keeping process. *Box 17* summarizes the full range of registers, ledgers, and files that are suggested here for maintenance purposes.

The maintenance record system can be a manual paper system or a computerized system – it doesn't matter, because the sort of data that needs to be recorded is the same whether you are designing the layout of a form or the fields on your computer screen. Also, any computer system involves an element of paperwork, as standard forms can be printed out for users or maintainers to fill in.

The rest of the discussion in this Section covers paper forms, and various manual ways to file them to create different sets of records. A computerized system would also be designed to store your records, not in physical cardboard files, but in various computer files. *Figure 11* presents the issues to consider if you want to computerize your maintenance record system.

BOX 17: Summary of Registers, Ledgers, and Files used for Maintenance, and Who Keeps Them

Equipment Users and Managers	<ul style="list-style-type: none"> ◆ Work Request/Job Forms used for recording the details of the request for maintenance support and also used by maintainers to record the work done (<i>Section 4.2</i>). ◆ User Department Maintenance Files to keep track of the requests made and their progress (<i>Section 4.2</i>). ◆ User PPM schedules for each type of equipment, PPM timetables and wall calendars (<i>Section 3.3</i>). ◆ Equipment cards attached to/kept with all pieces of equipment, showing user PPM and care instructions and service due dates (<i>Section 3.3</i>).
Maintainers	<ul style="list-style-type: none"> ◆ Work Request/Job Forms submitted by equipment users and used by the maintainers for recording the details of the work undertaken (<i>Section 4.2</i>). ◆ Personal Record Books to keep track of special problems and successes with work, which help to identify skill development needs (<i>Section 7.3</i>). ◆ PPM schedules for each type of equipment (<i>Section 3.3</i>). ◆ Equipment cards attached to/kept with all pieces of equipment used by the maintainers for recording dates when routine inspections, testing, and servicing took place, and are next due (<i>Section 3.3</i>).
HTM Manager (and possibly a Clerk)	<ul style="list-style-type: none"> ◆ Inventories of equipment, furniture, buildings, tools, etc (see <i>Guide 2</i>). ◆ PPM timetables and wall calendars showing when PPM was undertaken on different machines (<i>Section 3.3</i>). ◆ Job Pending Files and Job Completed Files kept by the HTM Team to keep track of the requests received and their progress (<i>Section 4.2</i>). ◆ A Contractors' Record Book/File to record which contractor undertook which job, and their performance (<i>Section 4.3</i>). ◆ Equipment Files and Section Files which create service histories (<i>Section 4.4</i>). ◆ Statistics Forms and Statistics Folders for keeping various statistical records for analysis and for compiling written reports for management (<i>Sections 8.2</i>).
HTM Team's Storesperson	<ul style="list-style-type: none"> ◆ A Tools Ledger in order to keep a record of: the tools owned, which staff members were allocated which tools, and the return of the tools at the end of the day (<i>Section 5.2</i>). ◆ Stock Cards used by the HTM Team's storesperson to record and keep track of the different items stocked in the storeroom (<i>Section 6.2</i>). ◆ A Stock Control Ledger kept by the HTM Team in order to monitor the quantities of parts and materials used and kept in stock (<i>Section 6.3</i>).

Figure 11: Issues to Consider When Computerizing Records

Step 1: Do I Need a Computerized System?

Questions	Considerations
<p>Have I already got a documentation system using forms alone?</p>	<p>Only acquire a computerized system once a documentation system using forms alone has been tested as an aid and optimized for users (unless the scale of a new project demands computerization).</p>
<p>What specific help do I expect from the computer as a tool?</p>	<p>A computerized system will mainly help with analyzing data and organizing workshop management procedures. Remember, work planning and PPM timetables can be perfectly well handled using a manual system, even for a large stock of equipment.</p>
<p>What costs will I incur when purchasing and operating a computerized system?</p>	<p>Try to estimate the purchase and operating costs – this is important because analyses are (initially at least) useful only for the information they provide, and seldom generate any direct economic benefit (this comes from the activities undertaken based on the data). Remember, operating costs include the cost of training the operators. Calculate the operating cost of the computerized system per bed (in the health facilities covered by the workshop record system) to ensure it is not too excessive.</p>
<p>How large a stock of equipment must I manage, and how many transactions must I make a year which require documentation?</p>	<p>A computerized system will only provide you with significant organizational help if there are meaningful 'quantities' involved. For example, one study reports that there should be at least 300 pieces of equipment and 700 document transactions per year.</p>
<p>Do I have the necessary material and staff resources to operate a computerized system?</p>	<p>As computer programs have become more user-friendly, staffing requirements have become less demanding. Some programs have built-in prompts and plausibility checks which rule out major entry errors and operating errors. The main issue is where best to locate the computerized system, in terms of staff skills.</p>
<p>What implications can I draw from these considerations, about the best location for a computerized system?</p>	<p>There is general agreement that a computerized system is only advisable at regional/provincial level or above. At district level, a computerized system is a drain on resources. At ministry level, on the other hand, computer-assisted analysis of data from health facilities throughout the country has long-term value.</p>

Continued opposite

Figure 11: Issues to Consider When Computerizing Records (continued)

Step 2: If I Do Need a Computerized System, What Type Should I Get?

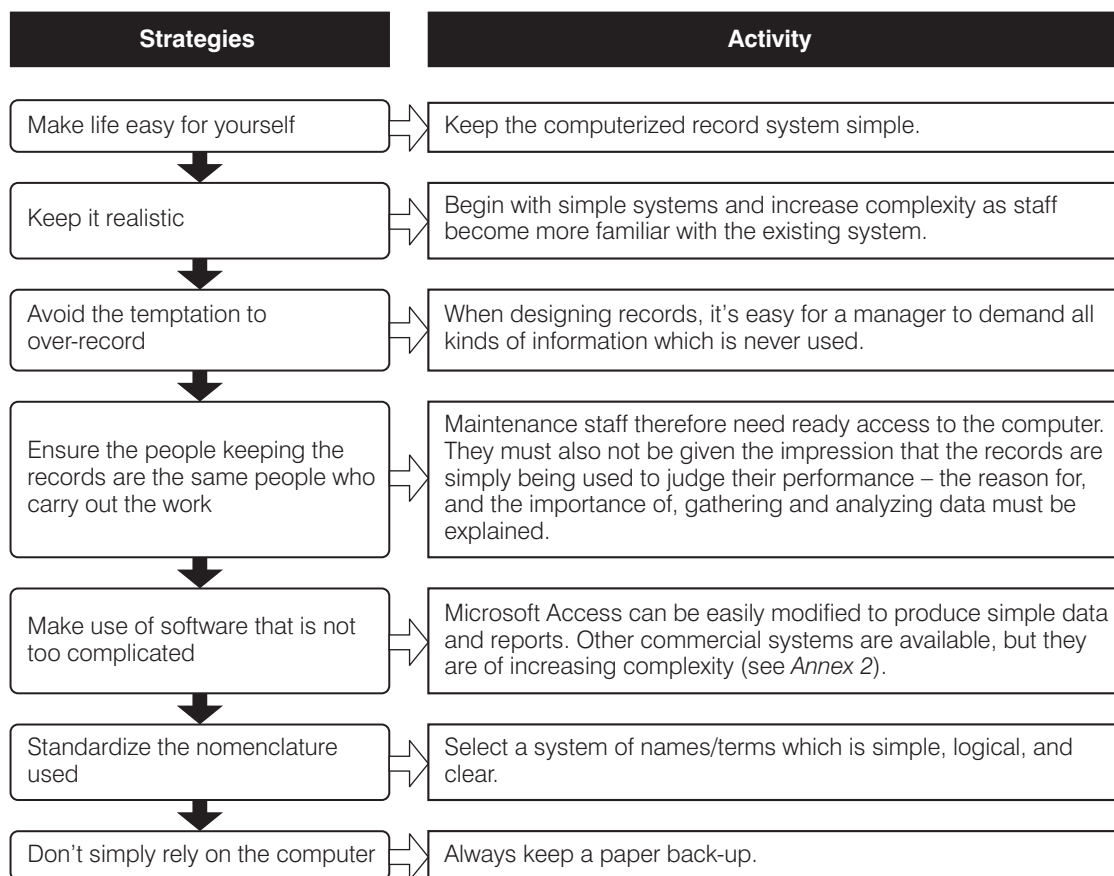

4.2 FAULT REPORTING AND MONITORING COMPLETION

Fault Reporting

Equipment users and their Section Heads are responsible for reporting all equipment faults **promptly** to the HTM Team (this should be part of the users' accountability towards equipment – see *Guide 4* on operation and safety). We suggest that a fault report should only be made by filling in some type of 'work request form', since relying solely on telephone calls or radio communication can mean that there is no physical record of the request made. In some instances staff may need to telephone or radio the HTM Team to report a fault; however, this process should be formalized through the creation of a written record of the reported fault. The HTM Team member receiving the call, and the equipment user making the call, should complete a work request form straight away as their own record of the call.

4.2 Fault reporting and monitoring completion

The type of form itself is very important, as it has multiple uses within the maintenance record system. If it is designed cleverly, it can combine a record of the request for maintenance from the user department with the details of the maintenance work undertaken for that particular job (*Section 4.3*). This then means that information about a request and its outcome stay together. An example of the sort of layout and content required for such a **Work Request/Job Form** is given in *Figure 12*.

Figure 12: Example of a Work Request/Job Form

Work Request/Job Form	
Note: this is a triplicate form – 1st sheet is the User File copy 2nd sheet is the Maintenance Progress File copy 3rd sheet is the Equipment/Section History File copy	
For User Department Only	
Facility: _____	Date: _____
Location: _____	
Person making request/In-charge (Full name, Position, Contact): _____	

Equipment task: _____	Inventory no. _____
Fault description: _____	

Equipment/Work order received by: _____	Date: _____
Equipment returned to (Full name): _____	Date: _____
For HTM Team Only	
Allocated to: _____	Section: _____
Type of service: _____ PPM _____	Repair _____
Serial no. _____	
Work undertaken: _____	

Reasons for failure: wear and tear: _____ mains unstable: _____ dirt: _____	
contamination (water, oil): _____ user error/handling: _____ faulty installation: _____	
other (specify): _____	
Materials used: _____	Quantity/Cost: _____

Test results: _____	
Work time: _____	Travel time: _____

Why not completed: _____	

Completed by: _____	
Maintainer's signature: _____	Date: _____

To function most effectively, the information recorded should be used for more than one purpose. We suggest the form is in triplicate, so that the multiple copies provide information for:

- i. the user department files
- ii. the HTM Team's files which keep track of all jobs completed, and those that are still outstanding
- iii. the service history files (*Section 4.4*).

The system you design may make use of fewer or more copies.

By using carbon paper with the triplicate form, the information only has to be written once – any initiative which saves the time and effort involved in keeping records is useful. If no carbon paper is available then the information would have to be written several times, or photocopied all the time. In due course, the form should become a standard printed triplicate order book. Every user section should have stocks of the forms: if they run out they can fill in a form at the workshop when they bring the equipment in for repair.

In the example shown, the person making the request fills in the **top half** of the form only. *Figure 12* shows that by filling in this form, the person requesting help provides important details about the reported fault.

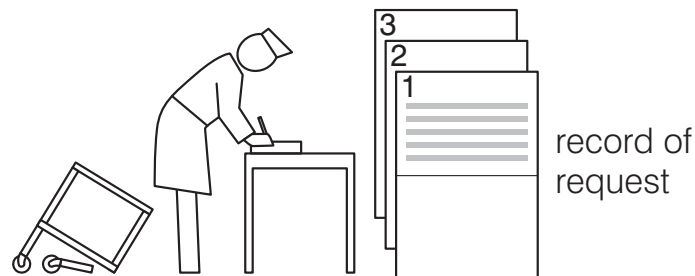

Work requests may come from anywhere – for example, when the HTM Manager wants planned preventive maintenance work done. In this case, the HTM Manager acts as a ‘user’ and fills in the top half of the form to request that his staff undertake PPM. In this way, the work undertaken during PPM is also recorded through the completion of a Work Request/Job Form. Thus, a form will be filled in for **every** job the maintenance department does or receives.

Monitoring Completion

Both the people making the request (the user department) and the people receiving the request (the HTM Team) need a way of registering all requests for maintenance support, and keeping track of whether jobs were attended to.

They could simply record work requests in a bound General Maintenance Register. The trouble with this method is that it is very difficult to track the progress with jobs. For example, to find out all the jobs that are still not finished, someone has to flick through every page and identify and count those that haven't been signed off. It's even harder to find the record of a specific job and see how it is progressing. If this level of record-keeping is all that can be managed by staff in the first instance, an example of a suggested layout for such a register is shown in *Annex 5*.

An alternative, and better, method, is to undertake some form of filing. If the suggested triplicate Work Request/Job Forms are used to ask for maintenance support, then filing the different copies can create a database of information for both the equipment users and the HTM Teams.

a. Progress Filing by the User Department

When the Section Head completes a triplicate Work Request/Job Form to ask for maintenance support, they keep the **top copy** for their records. They give the other two copies of the form to the HTM Team (for their records), either by handing them over to the maintainer when he or she arrives in the user department to repair immovable/fixed equipment, or by handing them in to the HTM Team when the user delivers portable equipment for repair.

We suggest that each user department has a **User Department Maintenance File**. In here, they file their copies of the Work Request/Job Forms and create a record of their requests all in one place which they can refer to at any time. To manage work in the department, it is important to keep track of which maintenance requests are still outstanding (pending) and which have been completed.

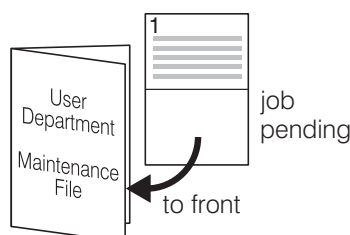

One way of designing such a file is to divide it in two, so that it becomes a record of all the maintenance work that the user department has asked for, as well as a record of those jobs that have been completed. The Work Request/Job Form is moved from the front of the file to the back when the job has been completed, so that the two halves work as follows:

- ◆ The front of the file is the **pending** section and is a record of all the jobs reported to the HTM Team, organized according to the date the report was made.
- ◆ The back of the file is the **completed** section and is an ongoing record of all the jobs that have been completed, organized according to the date they were finished.

When a job is completed (and the equipment is returned), the Section Head:

- ◆ goes to the User Department Maintenance File
- ◆ retrieves the Work Request/Job Form relevant to that job in the pending section
- ◆ signs it to acknowledge completion
- ◆ moves it to the completed section.

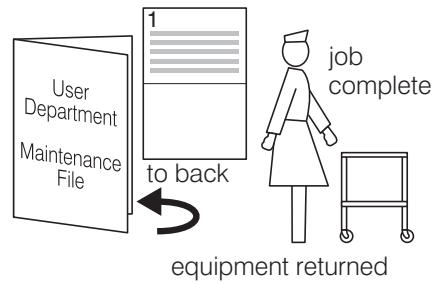

Whatever method is used, the department/facility initiating the job needs to keep a record of the number of requests made and monitor their progress. By reviewing the User Department Maintenance File regularly (at least every month), the Section Head obtains feedback regarding the status of maintenance requests and monitors progress (*Section 8*).

b. Progress Filing by the HTM Team

When the broken equipment is delivered to, or picked up by, the HTM Team, there will be two copies of the triplicate Work Request/Job Form with it.

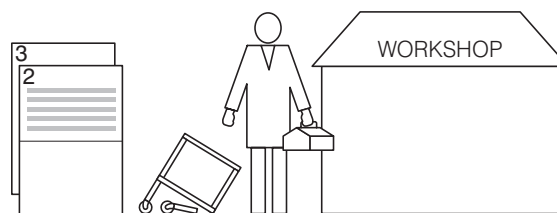

To manage maintenance work it is essential to know, at any time, which jobs are still outstanding (pending) and which have been completed. Thus, we suggest that the HTM Team uses **one** of these copies for the purpose of creating a record of their progress with all the jobs that come in. As the HTM Team will have many Work Request/Job Forms, we suggest that they keep separate files as follows:

- ◆ **A Jobs Pending File** which is a record of all the jobs that are reported to the HTM Team, organized according to the date that the report was made. For larger teams and workshops which have separate sections for different maintenance disciplines (civil, mechanical, medical, etc), a Jobs Pending File can be kept for each discipline.

4.2 Fault reporting and monitoring completion

- ◆ A **Jobs Completed File** which is an ongoing record of all jobs completed by the HTM Team, according to the date they were completed. For larger teams and workshops which have separate sections for different maintenance disciplines (civil, mechanical, medical, etc), a Jobs Completed File can be kept for each discipline.

When the Work Request/Job Form reaches the HTM Team, they place one copy into the Jobs Pending File. By placing each new request at the front of the file, an ongoing record is created of all the jobs that the team (or sub-section) is asked to do, in date order.

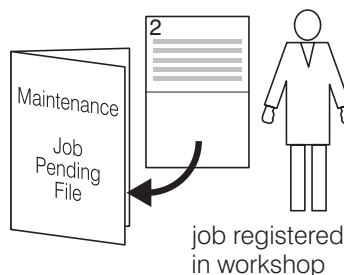

When a job has been completed, they move the relevant form from the Jobs Pending File and place it into the front of the Jobs Completed File. By placing the forms at the front of this file, an ongoing record is created of all the jobs that the team (or section) has completed, in date order.

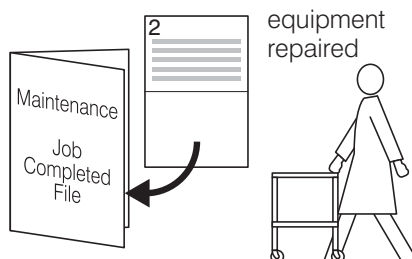

The HTM Team may wish to nominate (or hire) someone to be a clerk, to carry out all the filing and record-keeping tasks. Such files act as a useful record, keeping similar information together, and, as such, are valuable for weekly work-planning meetings (*Sections 3.1 and 7.2*) and for gathering statistics (*Section 8.2*).

As stated before, the HTM Team will receive two copies of the triplicate Work Request/Job Form with the broken equipment. We suggest that the **last** copy is used by the maintainer as a record of the work undertaken (as described in *Section 4.3*). The form can then be used to create a service history for the equipment or item concerned (described in *Section 4.4*).

Whatever method is used, the HTM Team needs to keep a record of the number of requests made and monitor their progress. By reviewing the Jobs Pending File at their weekly meeting, the team can plan its work for the forthcoming week.

4.3 MONITORING TEAM PROGRESS AND RECORDING WORK UNDERTAKEN

Whatever system is introduced, the HTM Manager needs to ensure that the team not only understand it, but also appreciate why it is necessary. It may well be a change in culture, which needs to be worked at in a sustained way. The benefits of monitoring team progress and recording work undertaken are:

- ◆ Openness – the provision of information for everyone to share
- ◆ Clarity – everyone can see what's going on at a glance
- ◆ Usefulness – a management tool to monitor the current status of work.

These are goals the HTM Team should be working towards in their maintenance record system, and goals the manager should be working towards in his or her management of maintenance staff.

Monitoring Team Progress

Once the HTM Team receives a Work Request/Job Form, the HTM Manager allocates the job to the appropriate individual/company (*Section 3.1*). We suggest that once jobs are allocated, there needs to be a system for seeing who is doing what, where the hold-ups are, and when a job is finished. A good management technique is to use a system which makes all staff – as well as the manager – aware of everyone's progress: in other words, how the team is coping with the workload.

An ideal arrangement is for each HTM Team to have some form of visual display of the jobs allocated and their progress. The aim of such a visual display is to show:

- ◆ the number and location of new job requests
- ◆ the number of allocated jobs in progress
- ◆ the number of jobs being undertaken by external contractors
- ◆ if any jobs have been held up (waiting for resources) and why
- ◆ that jobs have been completed.

In order to achieve this, some workshops may choose to have a specially designed **Slotted Board** which can be made locally out of wood or metal, and is mounted in the workshop. An example of the layout/structure of such a board is described in *Figure 13A*, and how to make it work is described in *Figure 13B*. For larger teams and workshops which have separate sections for different maintenance disciplines (civil, mechanical, medical, etc) there is a choice in the number and layout of the boards to use:

- ◆ If there is only one board and a lot of staff, the work 'In Progress' columns can be for each of the different maintenance sections (electrical, plumbing, etc).
- ◆ If there is a board for each maintenance section mounted at different locations, the work 'In Progress' columns can be for each individual member of staff.

Figure 13A: Slotted Board Format

This is an example of a possible layout for the Slotted Board which is mounted on a wall in each workshop to hold the Work Request/Job Forms. It can be made of wood or metal. It has many horizontal slats attached across it from top to bottom, providing vertical slots in each column for the Work Request/Job Forms to stand up in.

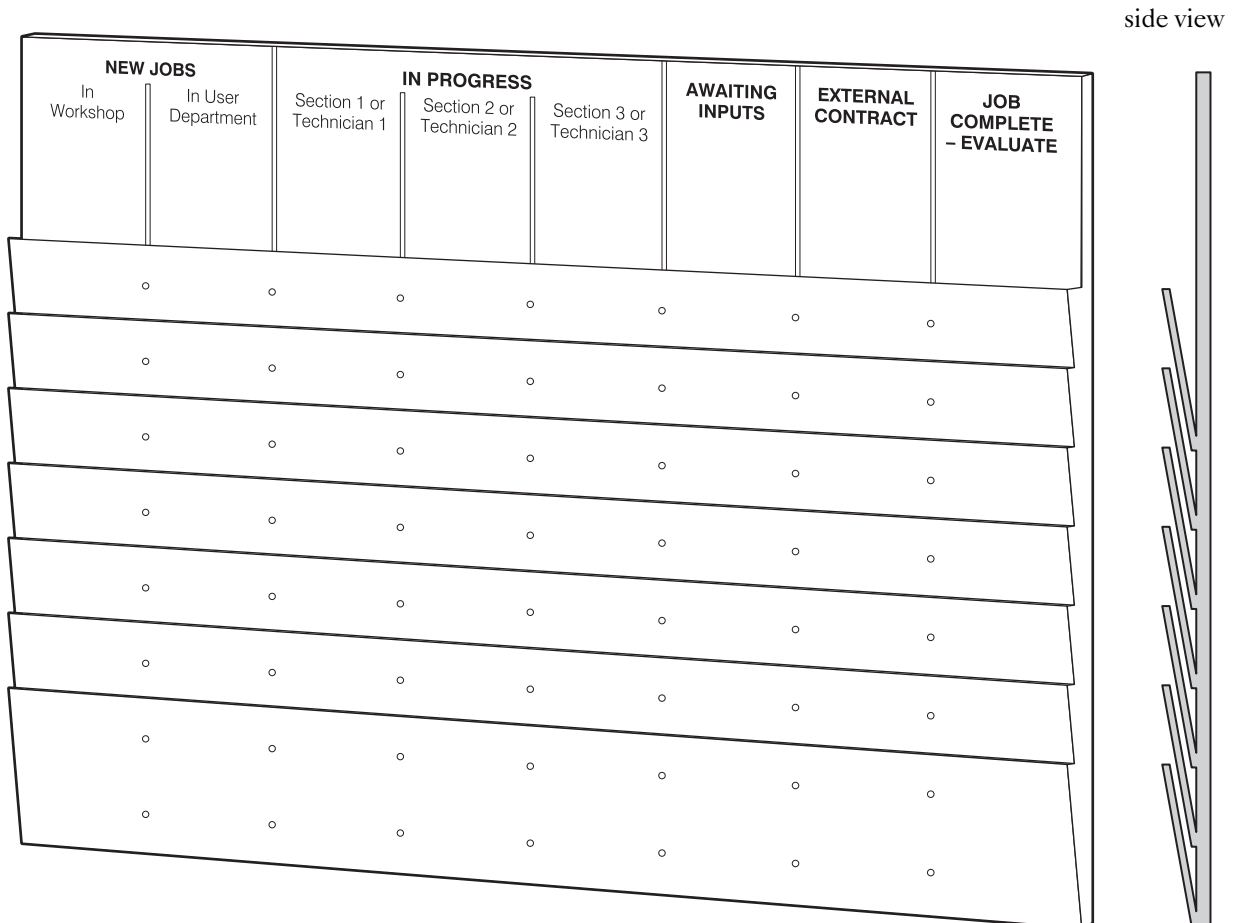

The columns on the Board are used for the following purposes:

- ◆ The 'New Jobs' columns show the number of new jobs requested, and whether the equipment is located in the workshop or in the user department.
- ◆ The 'In Progress' columns show which maintenance staff member or section has ongoing work, and how much of a workload they have.
- ◆ The 'External Contract' column shows whether a maintenance contractor is undertaking the work, and should be monitored.
- ◆ The 'Awaiting Inputs' column shows which jobs are held up waiting for spare parts, transport, funds, personnel, etc.
- ◆ The 'Job Complete - Evaluate' column shows how many jobs have been finished, and have forms filled in ready for analysis.

When the HTM Manager allocates each job to a member of his team, he or she places the Work Request/Job Form for that job in the next available slot in the appropriate column as described above. In this way, all job allocations are displayed along with the status of each job.

Figure 13B: How to Use the Slotted Board Shown in Figure 13A

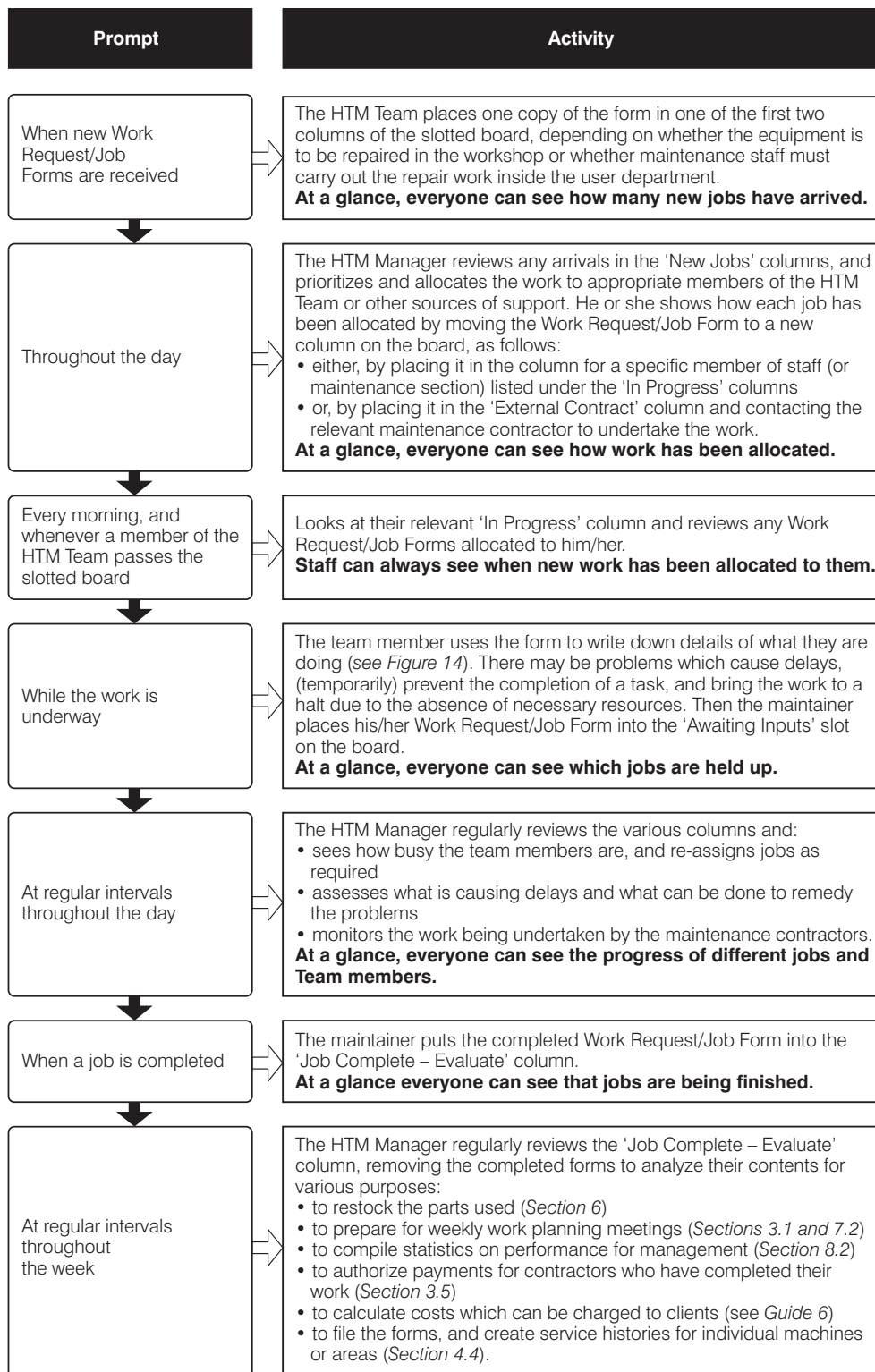

An alternative visual display system is to use black or white boards where jobs are written up and tracked in some way. The entries written on these boards can follow similar issues and progress as those described in *Figures 13 A and B*. Whichever display system is used, it may take time to introduce it to staff and for them to understand it. However once they do, it will be easy to use.

Recording the Work Undertaken

While working on equipment, maintainers need to record all the details of the task undertaken. This provides a record of the problem found and the corrective action taken, and is used for various maintenance management purposes. If a combined Work Request/Job Form is used (*Section 4.2*), the maintainer fills in the **bottom half** of the form. As *Figure 12* shows, in this way the maintainer provides important information about the fault found and the corrective actions taken.



When undertaking maintenance work, maintainers should follow a good practice checklist, such as the one provided in *Figure 14*.

Whenever a job is completed, either by a team member or by an external contractor, the maintainer responsible should sign off the job at the bottom of the form. He or she should also enter the date on the equipment card (*Section 3.3*) kept permanently with the equipment, and provide a new service due date. When the equipment is returned to the user, the maintainer should try to ensure that a senior member of staff in the user department signs for the return of the equipment as shown on the sample Work Request/Job Form (see *Figure 12*).

It might not be possible for a maintainer to finish a job at the first attempt, and there may be delays while they await the necessary spare parts, access to transport, funding, additional personnel or skills, etc. In this instance the Work Request/Job Form remains 'active' and should not be signed off until the job is completed.

As the maintainers use tools and test instruments, the HTM Team's storesperson keeps track of who is allocated which tool using a Tools Ledger (*Section 5.2*). As the maintainers use spare parts and maintenance materials, the HTM Team's storesperson keeps track of stocks using a Stock Control Ledger (*Section 6.3*).

As the work progresses, maintainers should keep a record of any special problems and successes they incur. They should enter this type of information into their Personal Record Book, and use it when discussing any skill development strategies or career opportunities with their manager (*Section 7.3*).

If the maintenance is undertaken by an external contractor, a member of the HTM Team should accompany the contractor. This team member liaises with the HTM Manager to record the outcome in the Contractors' Record Book/File. They should

Figure 14: Good Practice Checklist for Maintenance Staff when Undertaking Jobs

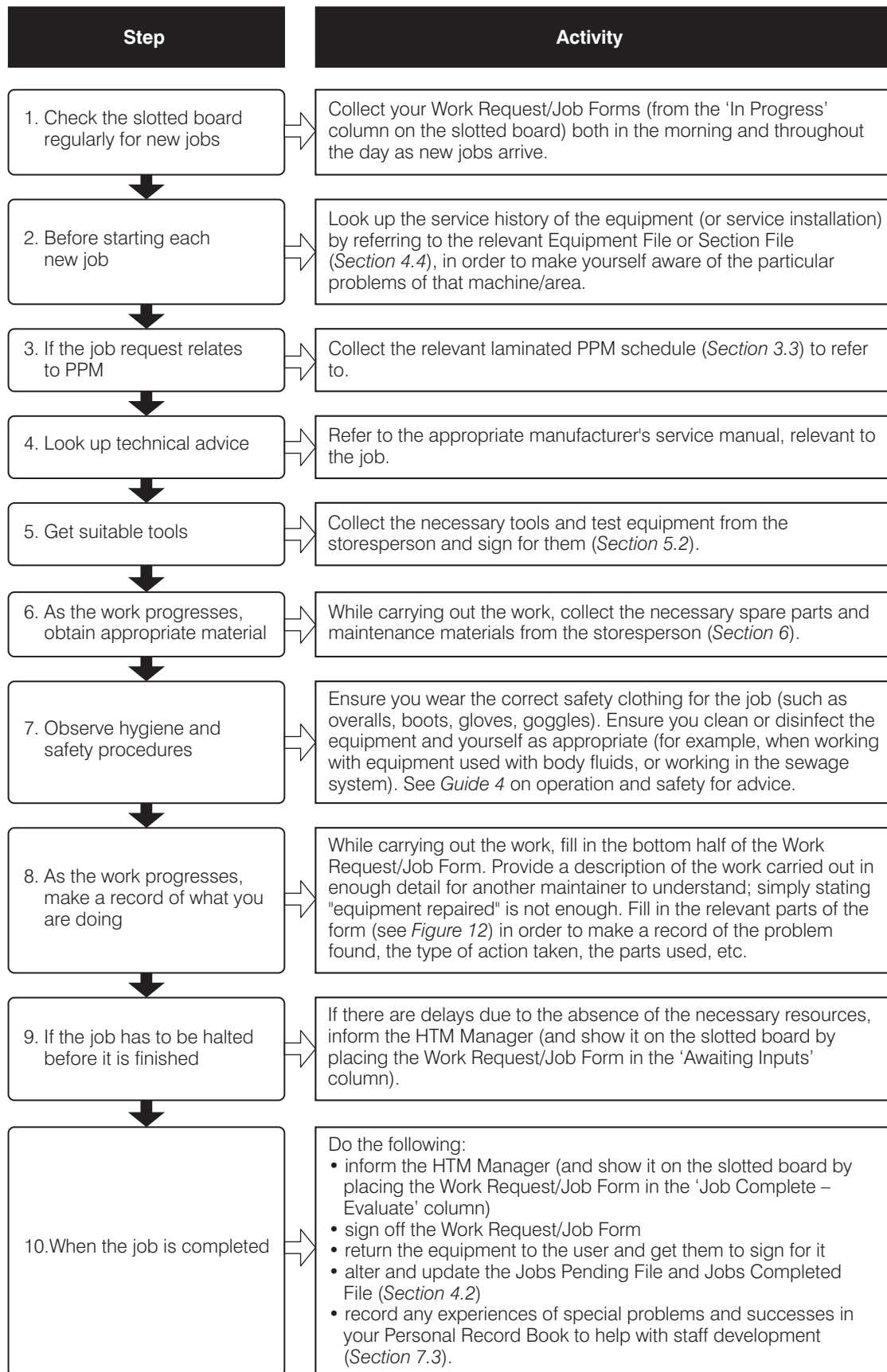

The HTM Manager uses the information recorded on this last copy of the Work Request/Job Form for various purposes:

- ◆ To restock the parts used (*Section 6*).
- ◆ To prepare for weekly work planning meetings (*Sections 3.1 and 7.2*).
- ◆ To compile statistics on performance for management (*Section 8.2*).
- ◆ To authorize payments for contractors who have completed their work (*Section 3.5*).
- ◆ To calculate costs which can be charged to clients (see *Guide 6*).
- ◆ To file the forms, and create service histories (*Section 4.4*).

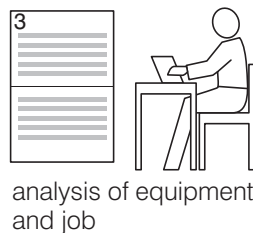

4.4 SERVICE HISTORY FILES

Equipment (both machines and installations) repeatedly requires attention over the years. Like a patient history file, a service history provides a record of the work done on each individual item over time, and keeps the records all in one place. This provides a reference where the specific problems of a machine or item/area can emerge.

It may be preferable to store the service history in two places, or the service history in one place and a summary in another. This will depend on the size of your organization, whether there are many levels to your Healthcare Technology Management Service, and whether you use a computerized management system. The information is required as follows:

- ◆ The complete service history is required in the maintenance workshop. Then maintainers can see what the recurring problems are with equipment and what work has already been done on the machine.
- ◆ Key facts from the service history (such as a shortened lifespan, a problematic machine) need to be linked to the equipment inventory. Then the Health Management Team can use it for planning purposes and for financial management and accounting purposes (see *Guide 2*).

The system described for monitoring team progress (*Section 4.3*) produces completed Work Request/Job Forms once the job is finished (in the final column of the slotted board). The HTM Manager collects these forms to analyze the data on them. Once this is done, we suggest that this **last** copy of the form is placed in a file for that particular machine or item/area, thereby creating individual service history files.

Maintainers should always refer to the relevant service history file when carrying out their work, because it will offer help by providing information on the machine about:

- ◆ recurring problems
- ◆ past actions taken
- ◆ user difficulties
- ◆ when PPM was undertaken
- ◆ test results
- ◆ contact details for the manufacturer, supplier, and local representative.

Service histories can be kept for work done on two different types of item:

- ◆ specific pieces of equipment – equipment service histories
- ◆ installations (such as pipe runs) not related to individual machines – section service histories.

Equipment Service Histories

Because each individual machine requires its own service history, we suggest that an **Equipment File** is set up and kept for each piece of equipment (such as a particular dental chair, or a particular suction pump). If you have given each item an inventory code number (see *Guide 2*), the Equipment Files can easily be stored and organized by this code number.

When setting up such a system, the HTM Team (or their clerk) can open such files for existing equipment as repair work occurs. But as new equipment arrives, the file should be opened during the commissioning/acceptance process. This process is described in detail in *Guide 3* on procurement and commissioning. The Commissioning Team should open the Equipment File when the equipment first arrives, and the first record in the file will be the completed 'Acceptance Test Logsheet' filled in at the commissioning and acceptance stage. This provides details of the new equipment, such as details of the manufacturer, service agent, price, warranty terms, technical specifications and installation date – see *Box 16*.

If a Work Request/Job Form is used (*Section 4.2*), the maintainer completes the form with details of the problems and work undertaken on a particular machine every time they work on it (*Section 4.3*). This completed last copy of the Work Request/Job Form can be filed to create a service history. Putting these forms in date order in a particular Equipment File for each machine will create a service history for that machine.

Section Service Histories

Some maintenance work will relate to service installations, pipe runs, tasks such as painting, or physical areas (such as a kitchen, corridor, or ward), rather than relating to specific pieces of equipment. Because this work also needs to be recorded as a service history for these items/areas of the health facility, we suggest that you set up **Section Files** for the different maintenance disciplines, such as painting, building, electrical, etc.

For example, the plumber can record repairing a portion of sewage pipe or the painter can record painting a wall on a Work Request/Job Form, but these tasks have no equipment specifically related to them and therefore no specific equipment files. However, the last copy of the Work Request/Job Form can be filed in the appropriate Section File and will create a service history of the work done for those items/areas.

When setting up such a system, the HTM Team (or their clerk) can open such files for existing installations/areas as repair work occurs. However, if new construction takes place and new installations are provided, the Section File should be opened during the commissioning/handover process (see *Guide 3*). The Commissioning Team should ensure the first record in the file is the results of the commissioning tests, together with any necessary details about the technology and its supplier – see relevant data in *Box 16*.

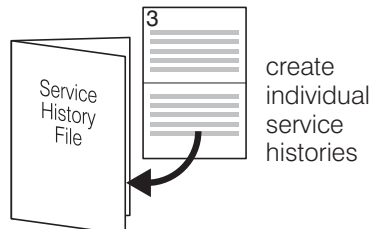
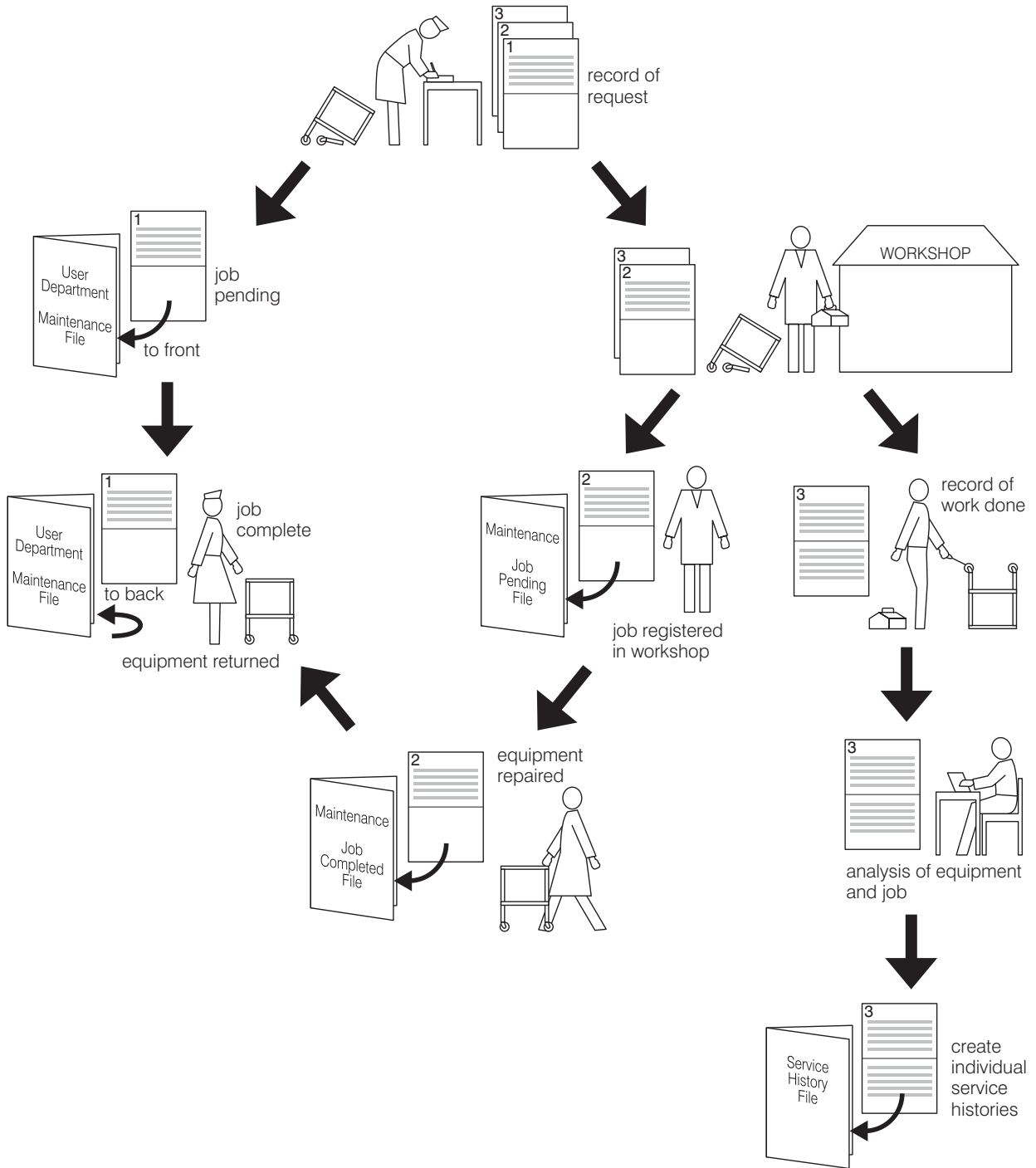

Figure 15 provides a summary of the use of the triplicate Work Request/Job Form in the maintenance record system.

Figure 15: Summary of the Use of the Work Request/Job Form



Box 18 contains a summary of the issues covered in this Section.

BOX 18: Summary of Procedures in Section 4 on a Maintenance Record System

General	Health Technology Management Service	<ul style="list-style-type: none"> ◆ designs the maintenance record system (linked to the inventory code system), its forms, files, ledgers, etc (or a computerized system), and introduces it to all HTM Teams and health facilities (see <i>Box 17</i>)
	Health Management Teams	<ul style="list-style-type: none"> ◆ ensure stocks of relevant forms, files, and ledgers are available for the HTM Teams and all user departments
	HTM Managers	<ul style="list-style-type: none"> ◆ ensure that all parts of the maintenance record system are being used and kept up- to-date by the relevant staff members
Report Faults and Monitor Completion	Equipment Users	<ul style="list-style-type: none"> ◆ report any faults to their Section Head immediately they occur
	User Departments' Section Heads	<ul style="list-style-type: none"> ◆ fill in the Work Request/Job Form (see <i>Figure 12</i>) as soon as a problem is reported, and hand over the relevant copies to the HTM Team with the broken equipment ◆ file their copy of the form in a User Department Maintenance File ◆ when a job is completed (and the equipment is returned) sign off the relevant form and move it to the back of the User Department Maintenance File ◆ regularly review the User Department Maintenance File to monitor progress (<i>Section 8.2</i>)
	HTM Managers	<ul style="list-style-type: none"> ◆ fill in the top half of a Work Request/Job Form every time they want to request maintenance staff to undertake PPM work, so that a form is used for every job the HTM Team does
	HTM Teams	<ul style="list-style-type: none"> ◆ collect/receive relevant copies of the Work Request/Job Form for each maintenance job requested (including PPM) or broken equipment submitted ◆ create a Jobs Pending File by filing one copy of the form ◆ when a job is completed move the relevant form from the Jobs Pending File into a Jobs Completed File

Continued opposite

BOX 18: Summary of Procedures in Section 4 on a Maintenance Record System (continued)

Monitor Progress and Record Work	HTM Managers	<ul style="list-style-type: none"> ◆ install some form of visual display system (see <i>Figures 13 A and B</i>) and use the Work Request/Job Forms or writing to: <ul style="list-style-type: none"> - display the arrival of new jobs - show their allocation to staff members, any delays, the use of external contractors, and the completion of work - monitor progress regularly in order to remedy any problems ◆ when jobs are finished, collect the completed Work Request/Job Forms and analyze the data on them for various purposes such as preparing for weekly work planning meetings, preparing statistics and reports, and for managing stocks, tools, and contracts (<i>Sections 5 to 8</i>)
	HTM Teams	<ul style="list-style-type: none"> ◆ refer to the display board for the jobs allocated to them, use it to record progress with each job, and inform the HTM Manager of any delays (see <i>Figure 14</i>) ◆ fill in the Work Request/Job Form with all the details of the job (including PPM work) ◆ when the job is complete, sign off the form, return the equipment to the user and get them to sign for receipt of the equipment ◆ accompany any external contractor, and fill in the Contractors' Record Book/File ◆ record any experiences of special problems and successes in their Personal Record Books to help with staff development (<i>Section 7</i>)
Service Histories	HTM Managers	<ul style="list-style-type: none"> ◆ after analyzing the completed Work Request/Job Forms, file them in their individual Equipment File or Section File to create a service history (see <i>Figure 15</i>)
	HTM Teams	<ul style="list-style-type: none"> ◆ set up an Equipment File for each individual piece of equipment, and a Section File for items such as service installations, pipe runs, painting, areas, etc: <ul style="list-style-type: none"> - either as and when repair work is carried out on existing equipment - or at the time new items are commissioned, when the first record in the file will be the 'Acceptance Test Logsheet' (see <i>Guide 3</i>) ◆ refer to the relevant service history file when undertaking maintenance or repair, in order to identify recurring problems and past actions taken on each machine

5. HOW TO MANAGE TOOLS AND WORK FACILITIES

Why Is This Important?

Tools are a very important ingredient for HTM Teams. Their availability in adequate quantities is key to a successful maintenance programme.

Adequate working space and resources are also crucial for HTM Teams if they are to perform their work effectively.

This Section looks at how to provide the best working environment for HTM Teams, through the following issues:

- ◆ Tools requirements (*Section 5.1*).
- ◆ Security and a storage system for tools (*Section 5.2*).
- ◆ Managing the work space (*Section 5.3*).

5.1 TOOLS REQUIREMENTS

Some of this Section may appear similar to the discussion regarding spare parts and maintenance materials (*Section 6*). The key difference is that tools are capital items, can be very expensive, are paid for from the capital budget, and are usually only purchased annually.

Availability

Various different tool kits should be available for the separate maintenance disciplines (painting, mechanics, refrigeration, etc), and for different skill levels. For example, an electrician (at technician grade) uses a larger, more complex range of tools than an electrician's assistant (at craftsperson grade). These tool kits should include hand tools and bench tools. In addition, we strongly recommend that there are performance and safety testing instruments as well (*Section 3.4*). Reference literature provides a range of advice on the tools required (see *Annex 2*), and a summary list of suggestions is given in *Annex 6*.

Once tools are purchased, it is imperative that they are looked after properly, are kept secure, and are inventoried, in order to ensure they are always available for use.

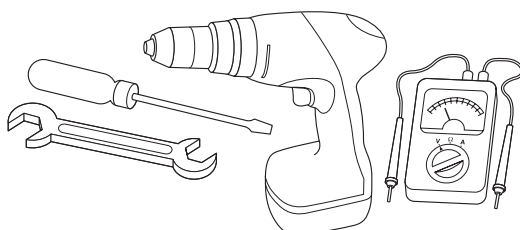

Finance

If maintenance work is to continue, tools and test instruments must always be available. Thus, continually finding money for these items will be a challenge as long as a maintenance service exists. Hand and bench tools, and test instruments are important and sometimes complex pieces of equipment in their own right, and therefore can be very expensive items. *Guide 2* of this Series provides guidance and procedures on budgeting for procurement and maintenance.

Procurement Issues

The quality and effectiveness of a repair job is often jeopardized by the use of low quality tools. Poor tools may break if they are not strong enough, they may fail earlier than expected, or they may rub, corrode, or in some way damage other parts of the machine. Even if you are experienced at using tools:

- ◆ poor quality drill bits will break quickly
- ◆ spanners made to poor tolerances will rub the edges off nuts
- ◆ screwdrivers made of poor materials will destroy screw heads.

Cost and quality often go together. Well-known tool manufacturers often produce better products than companies making 'lookalikes'. Many companies are set up solely for the purpose of manufacturing lookalikes – these products are often (but not always) cheaper, but may be of inferior quality. We recommend that, as the items get more technically complex or critical, you should try and buy better quality tools and test instruments. A discussion on sourcing and obtaining good quality products can be found in *Guide 3* on procurement and commissioning. However, there may be an argument for buying lower quality tools at a much lower price, provided the tools can be replaced when necessary. See below, and *Guide 2*, for a discussion on replacement budgeting.

Ownership and Replacement

The health service provider needs to choose whether to purchase and own the tools themselves, or whether to rely on individual staff members to bring to work tools which are their own personal property in order to undertake their particular professional skills. *Box 19* presents the advantages and disadvantages of both arrangements, and many health service providers may use a combination of strategies.

BOX 19: Advantages and Disadvantages of Tool Ownership

If tools are purchased by the health service provider	<ul style="list-style-type: none"> ◆ They become health service property. ◆ Strategies must then be put in place to reduce loss and theft, and to penalize staff found abusing the tools. ◆ When tools reach the end of their life, there must also be a formal process where the production of a worn-out tool leads to it being decommissioned (like equipment), and a replacement bought through the normal purchasing programmes of the health service provider.
If maintenance work relies upon staff members bringing their own personal tools to work	<ul style="list-style-type: none"> ◆ When the individual leaves, the health service provider no longer has the tools required for the work. ◆ The health service provider also has to give the staff member a tools allowance so that he or she can replace each tool as it deteriorates due to the normal wear and tear caused by undertaking the daily work for the health service.

5.2 SECURITY AND A STORAGE SYSTEM FOR TOOLS

There are many other issues to consider concerning tools, such as their security, access to them during different shifts, keeping track of them, loss and theft, disciplinary methods, etc. The action you take on all of these issues will depend a great deal on the work culture in your country, and the experience you have had with problems surrounding tools. This Section discusses some matters which you need to consider. You don't need to agree with all of the suggestions made, but they raise the matters that you and your health service provider will have to find solutions for. Remember that tools are a valuable resource, and without them you cannot do your work.

Issue and Responsibility

Each HTM Team needs to have a Tools Inventory, which will be a subset of the Equipment Inventory (see *Guide 2*). This provides a detailed listing of all items, such as test and bench instruments, and the contents of tool kits, owned by, and located with, the HTM Team.

It is necessary to ensure the security of all tools belonging to each HTM Team/workshop. Also it is necessary to retain ownership of the tools within the health service if they own the tools, or guarantee the safety of personal tools belonging to staff. Ultimately, the responsibility for tool security during working hours should fall to the staff using the tools. But the Health Management Team must provide adequate security measures for the working environment. It is important to remember that tools are attractive items to any opportunist thieves wandering around the health facility site.

5.2 Security and a storage system for tools

Box 20 presents different levels of security to consider for tools. Different health service providers will use combinations of different strategies. There needs to be a balance between adequate access to tools so that work can continue, and sufficient security so that assets are not stolen (by the public or by staff).

BOX 20: Possible Security Strategies to Consider for Tools

Use a liberal approach	<ul style="list-style-type: none"> ◆ Find a suitable combination of security and adequate access for usual working methods. ◆ Avoid having workers signing everything in and out frequently, as this uses up a great deal of costly time. ◆ Lock away expensive items, such as oscilloscopes, and only issue them with a signature. ◆ Leave basic tools in view in the workshop, allowing for the immediate testing of a bright idea that a maintainer may have. ◆ Be wary of punishing staff for breakages – check whether they are breaking more tools because they are using them more often while undertaking more work than others. ◆ Trust staff to look after their tools. ◆ Introduce a level of security to the workshop premises in order to keep the inventory of tools secure from outsiders.
Use peer pressure	<ul style="list-style-type: none"> ◆ Make maintainers collectively responsible for tools and test instruments. ◆ If any are lost, make the entire HTM Team contribute to the cost of replacing them. ◆ Benefit from the peer pressure created – this helps to keep account of tools and works well.
Use a strict approach	<ul style="list-style-type: none"> ◆ When not in use, hold all tools in a secure tool storeroom at the HTM Team's premises/workshop. ◆ Nominate a member of the HTM Team, such as the storesperson, to be the 'authorized issuer of tools'. ◆ Restrict access to the keys for the tool storeroom to the HTM Manager and the nominated storesperson. ◆ Each morning, make it the responsibility of the storesperson to issue tool kits (or parts of them) to the relevant maintenance staff, necessary for the day's work. Both the storesperson issuing the tool, and the individuals receiving tools, must sign for them in the Tools Ledger (<i>Section 5.2</i>). This also provides an opportunity for making sure that all tools listed on the inventory are present in the tool kit. ◆ During the day, the maintainer who received and signed for the tools has sole responsibility for the tools he or she has been issued with. ◆ Keep specialized tools (hand or bench tools which aren't used regularly every day) in the tools store, and only issue and sign them out as and when required. ◆ At the end of the working day, everyone signs their tools back in with the storesperson. This can also be an opportunity for making sure all tools signed out that morning have been returned in the same condition as when issued. ◆ At weekends or during call-outs at night: <ul style="list-style-type: none"> - link access to tools to the duty rota - allow staff working outside normal working hours to keep tools with them to enable them to attend to call-outs without problems - make them sign their tools back in with the storesperson at the start of the next official shift. ◆ At the end of each week, the storesperson checks to ensure that all tools are still present according to the Tools Inventory, and reports their findings to the HTM Manager.

Loss and Discipline

It is inevitable that tools will be lost or damaged from time to time. Any such loss or damage will become evident at the end of each week when the Tools Inventory is checked. Tools which have become damaged due to normal wear and tear should not be charged to the signatory. However, your organization should consider what action will be taken if tools are missing or abused, and if particular individuals are the persistent cause of problems. Good or bad performance when using tools can then be discussed in the staff appraisal process (*Section 7.3*).

Your response to good and bad performance will depend on local human resources policies and procedures, your strategies for motivating staff (*Section 2.1*), and whether you take a positive approach, a disciplinary approach, or a combination of the two.

One option is to take a positive approach which encourages good behaviour. Staff who consistently treat their equipment well and take care of it are given a reward as an incentive. This could be the chance to attend a skills-development course, or perhaps nomination as a trainer of others: the strategies chosen would depend on the type of tools and skills involved. For example, individual staff members may be issued with tools that are checked once a week (or once a month). Anyone who has a complete toolbox every three (or six) months is given a bonus: some batteries for example, or the right to 'lose' an item without penalty. After five years, possibly the toolbox could become the property of the staff member.

Another option is to take a disciplinary approach, and establish mechanisms so missing and abused tools can be charged to staff. This method aims to make the signatory for tools more accountable for their actions. Such charges may be deducted from their salary by instalments, or, in the case of more expensive items, penalties may be incurred in the individual's terminal benefits. Persistent offending may result in termination of employment.

Such a system, if adopted, must be fair: only tackle individuals who abuse or steal tools intentionally (*Section 2.1*). Each case should be assessed individually, using formal disciplinary hearing procedures. Finance and salary departments should base fines on realistic quotes for replacing the tools.

However, any approach taken to enforce rules for maintenance staff is only workable if it takes place in the right working environment, otherwise petty tyranny may prevail. Help to make staff more accountable by clearly setting out their responsibilities towards tools. The most important thing is for staff to be in an environment where their managers are present, involved, expect the correct results, and are seen to perform well themselves.

Storage of Tools

It is useful to have an organized way of storing tools rather than just a jumbled heap of items. Your strategies will depend on:

- ◆ your tools policy
- ◆ whether your tools are kept out in the open in the maintenance premises/workshop or locked away in a secure tool storeroom
- ◆ how much travelling your staff do, such as maintenance by outreach
- ◆ when tools must be available, such as during a night shift.

Box 21 presents a variety of initiatives that different technical teams have used.

BOX 21: Various Initiatives for Storing Tools

Steel tool boxes	These contain cantilevered trays and usefully store items such as a mechanic's or electrician's hand-tools.
Canvas carry-all bags	These usefully store items such as a carpenter's or painter's hand-tools.
Wall-mounted boards	These contain hooks and nails and loops positioned appropriately so that tools can be hung up – possibly with the outline of the tool drawn on the board so that it is obvious where each tool should hang and which ones are missing.
Lockable tool cupboards	These contain shelves for test instruments and sets (such as allen keys and socket sets), as well as hanging spaces for tools (as described above).
Lockable wooden or metal storage boxes	These can be stored, and even bolted down, in the back of a van or mobile workshop for outreach work.

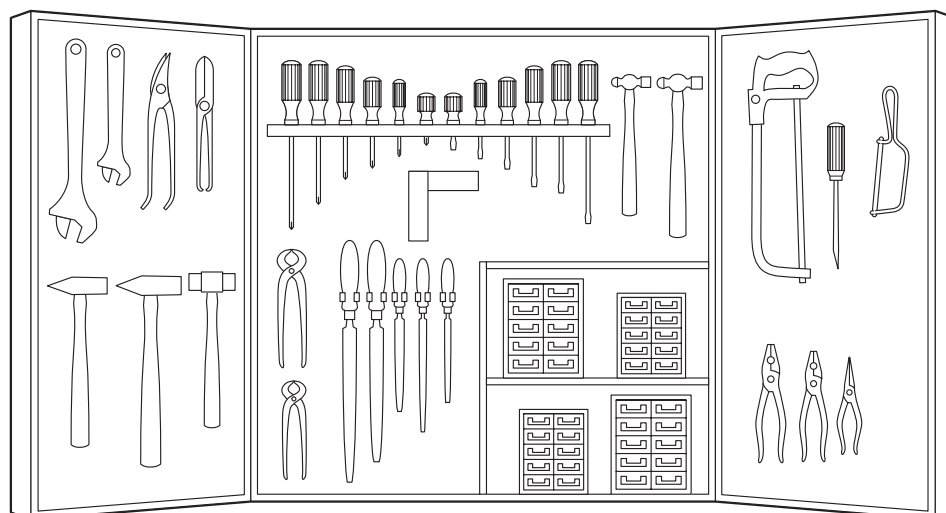

It is useful to remember that how you position and mount your bench tools will affect how well you can use your workshop space (*Section 5.3*).

A **Tools Ledger** can be designed to ensure that it is possible to always know where tools are and who has them, even when staff work off site (for example, at staff accommodation), or on outreach trips over a period of days (*Section 3.6*).

We suggest that the Tools Ledger be a book rather than pieces of paper which are filed, since sheets of paper detailing who signed for a tool can easily go missing. For larger HTM Teams and workshops which have separate sections for different maintenance disciplines (carpentry, electrical, plumbing, medical, etc), a Tools Ledger can be kept for each discipline. This makes it easier to keep track of tools under the responsibility of different work teams.

The Tools Ledger book should be divided in two. This way it can be a record of the issuing of tools as well as a checklist inventory of the tools for that maintenance section. The two halves work as follows:

- ◆ The front of the book is used as a Tools Issue Register with a double-page spread to record the use of tools daily (or weekly, depending on the level of security chosen – see *Box 20*). An example of how it can be laid out is shown in *Figure 16*.
- ◆ The back of the book contains a list of all the tools owned by that maintenance section (the bench tools, the contents of the various hand-tool kits, and the test instruments), to act as an inventory of the tools. Against this list there are weekly (or monthly) columns, where ticks are placed if the tools are present at the end-of-week (or month) check.

Figure 16: Suggested Format for the Tools Issue Register

This is an example of a possible layout for the double-page spread within an A4 book which can act as the Tools Issue Register, with an example included of the type of entries. Large HTM Teams could set up a book for each different maintenance discipline.

OUT						IN			
Date	Qty	Item	Storekeeper's signature/initials	Technician taking tools out	Technician's signature	Date	Signature of technician returning tools	Storekeeper's signature/initials	Remarks
6/4	1	Saw	JK	CC	<i>C. Chandele</i>	6/4	<i>C. Chandele</i>	JK	In good condition
7/4	2	Multimeter	JK	WK	<i>W. Khan</i>	7/4	<i>W. Khan</i>	JK	Left at Doctor's house
						8/4	<i>W. Khan</i>	JK	Multimeter returned

5.3 MANAGING THE WORK SPACE

Reference literature provides a range of advice on the design and layout of workshops (see *Annex 2*), which vary depending on the size of the HTM Team and what their responsibilities are. However, most agree on the various elements required, as follows:

- ◆ Different working areas for different maintenance disciplines. For example, welding, electronic, mechanical, and carpentry. (Note: because medical equipment maintenance work is much finer and more delicate than for other items, medium to large health facilities will require a separate dedicated workspace that can be kept clean for this work).
- ◆ Suitable work-benches, storage cabinets, stools, etc for each work area.
- ◆ Secure storerooms for spare parts and bulk deliveries of raw materials.
- ◆ An office area with desks, filing cabinets, noticeboard, shelves for the library, etc.
- ◆ Changing rooms with lockers, benches, shower, toilet, etc.
- ◆ Cleaning/draining areas with a sink.
- ◆ Shaded outside working areas for handling larger items and raw materials, or for dirty jobs, a vehicle pit, etc.
- ◆ Secure outside storage areas for gas bottles, decommissioned equipment awaiting disposal, etc.
- ◆ Vehicle access.

Figure 17 presents a diagram of a workshop layout which includes most of these elements. Another three layouts from a variety of sources are provided in *Annex 7*. All these sources were providing layouts for workshops that undertake district-level activities.

It is useful to remember that how you position and mount your bench tools affects how well you can use your workshop space. When planning the layout of your workshop, it is important to consider how the staff do their work. A great deal of time and energy can be wasted, and traffic-jams caused, by poor placement of bench tools.

Figure 17: Typical Layout for a Workshop of a 100-Bed Hospital

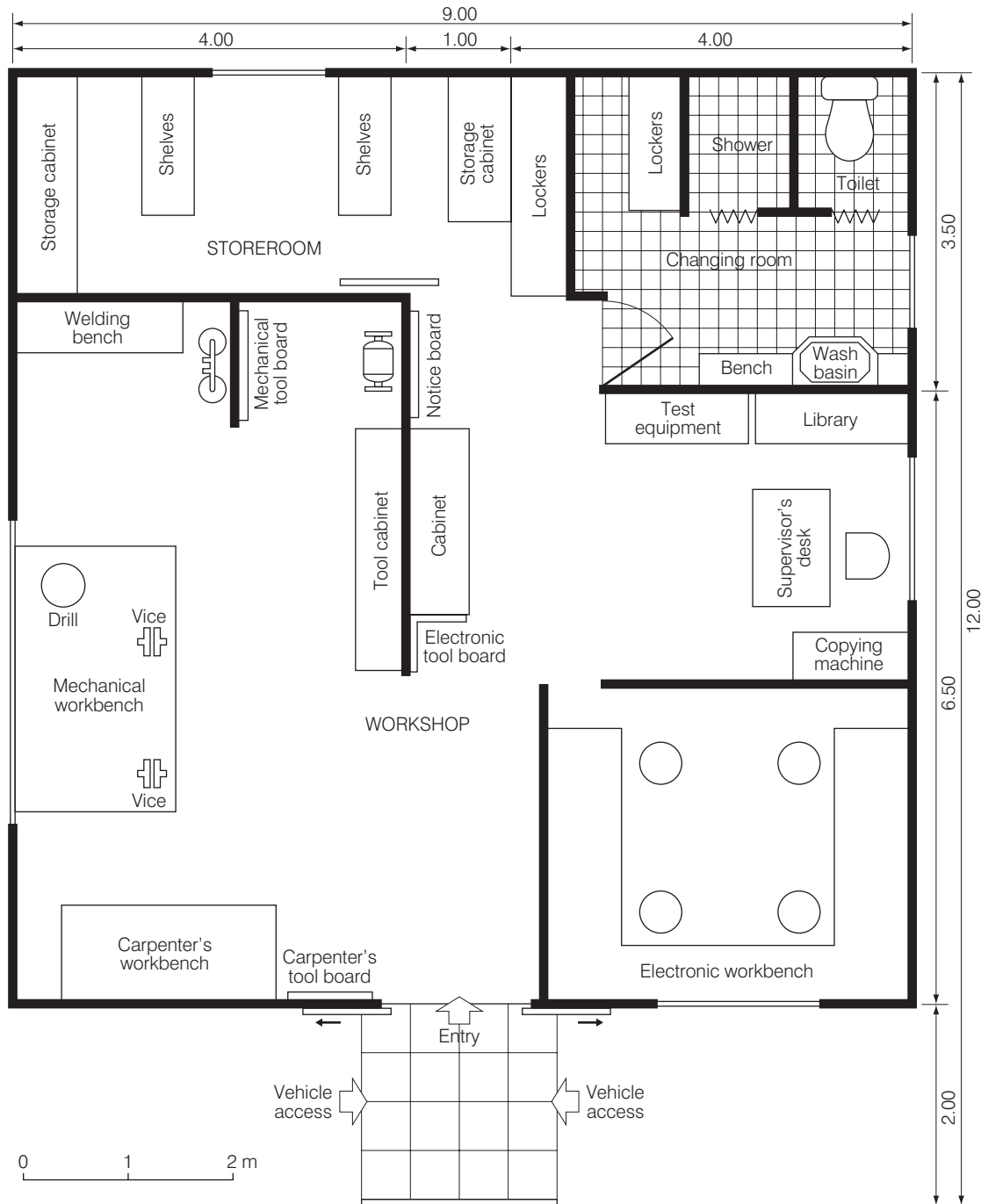

Source: WHO Regional Office for the Western Pacific, 1996, 'District hospitals: guidelines for development', 2nd edition, Western Pacific Series No.4, WHO Regional Publications, Manila, Philippines

5.3 Managing the work space

An example of a bad layout is shown in *Figure 18* where:

- ◆ the plumber enters the workshop with long lengths of pipe and travels to the far side of the room to reach the pipe cutter (getting in everyone else's way)
- ◆ then takes the shorter pieces diagonally across the room to reach the grinder (passing through other people's work areas)
- ◆ then moves the pieces to another bench to get access to a vice to use a die for threading.

It may be beneficial to discuss your needs with an architect in order to get a space that works well.

Figure 18: Example of the Problems of a Poorly Laid Out Workshop

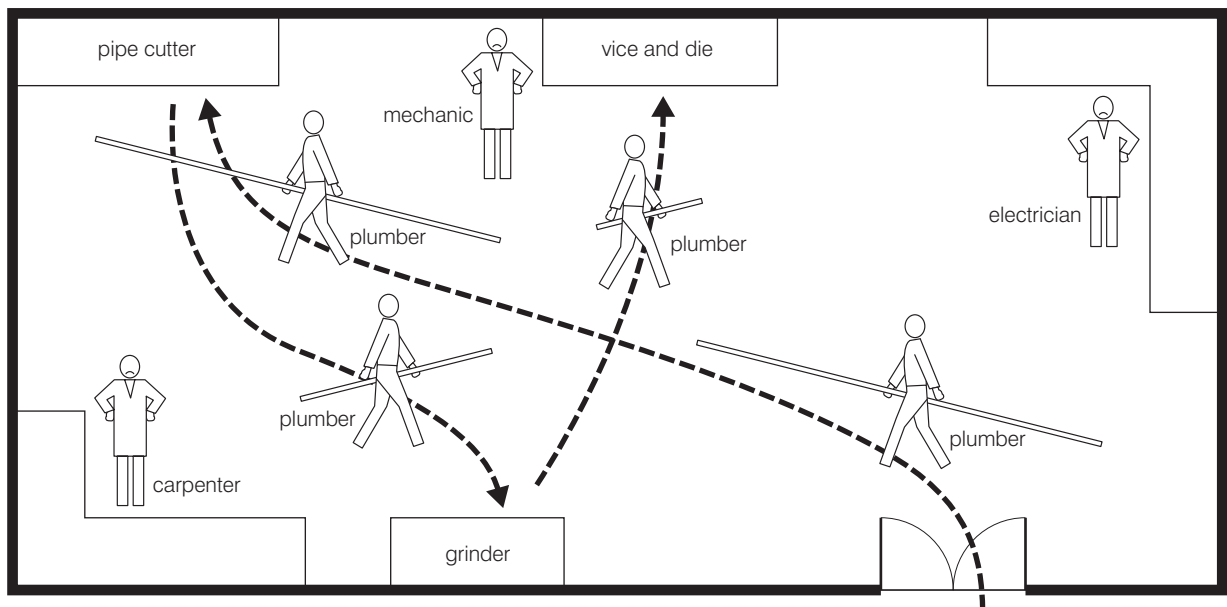

Other requirements for workshops are:

- ◆ adequate manuals and technical literature (see *Box 7* in *Section 3.2* for strategies)
- ◆ sufficient protective clothing, such as gloves, overalls, goggles, boots, etc (see *Guide 4* on operation and safety)
- ◆ safe storage of hazardous materials, such as gas, oil, chemicals, etc (see *Guide 4*)
- ◆ correct disposal methods for maintenance waste (this is discussed in *Guide 4*).

Box 22 contains a summary of the issues covered in this Section.

BOX 22: Summary of Procedures in Section 5 on Managing Tools and Work Facilities

Tools Needs	Health Service Provider	<ul style="list-style-type: none"> ◆ ensures that finances for adequate hand and bench tools, and test instruments are available for the HTM Teams (see <i>Box 12</i> and <i>Annex 6</i>) ◆ decides who will own the tools (see <i>Box 19</i>)
	HTM Managers at central level	<ul style="list-style-type: none"> ◆ decide which tools are required for the HTM Teams at different levels of the HTM Service (see <i>Annex 6</i>)
	Health Management Teams	<ul style="list-style-type: none"> ◆ either buy good quality tools, or lower quality tools which they replace regularly
Security and Storage	Health Service Provider	<ul style="list-style-type: none"> ◆ decides the type of tool security strategy to adopt (see <i>Box 20</i>) ◆ agrees the action to be taken by the Human Resources Department if persistent loss or abuse of tools is discovered ◆ agrees incentives for good performance with the Human Resources Department
	HTM Managers (at all levels of the HTMS)	<ul style="list-style-type: none"> ◆ implement the agreed tool security, issue, and responsibility arrangements at maintenance workshops/premises ◆ design the Tools Ledger ◆ create suitable storage spaces for tools (see <i>Box 21</i>) ◆ nominate a suitable member of the team as the storesperson or authorized issuer of tools
	HTM Teams	<ul style="list-style-type: none"> ◆ keep the Tools Inventory up-to-date with regular (weekly) checks ◆ use the Tools Issue Register to record the issue and return of tools (see <i>Figure 16</i>) ◆ handle tools well so they are not damaged
Work Facilities	Health Service Provider	<ul style="list-style-type: none"> ◆ ensures adequate work facilities are available for the HTM Teams, together with sufficient protective clothing
	HTM Service	<ul style="list-style-type: none"> ◆ develops good designs for the layout of workshops and working premises
	HTM Teams	<ul style="list-style-type: none"> ◆ keep work spaces functioning efficiently ◆ use protective clothing (see <i>Guide 4</i>) ◆ store hazardous materials safely (see <i>Guide 4</i>) ◆ dispose of maintenance waste correctly (see <i>Guide 4</i>)

6. HOW TO ENSURE THE AVAILABILITY OF SPARE PARTS AND MAINTENANCE MATERIALS

Why is This Important?

Equipment spare parts and maintenance materials are essential because without them equipment cannot be maintained or repaired.

Ensuring that suitable equipment spare parts and maintenance materials are always available is a vital management issue.

This Section looks at assessing the need for equipment spare parts and maintenance materials, through the following issues:

- ◆ A general discussion on spare parts and maintenance materials (*Section 6.1*).
- ◆ The storage system and procedures (*Section 6.2*).
- ◆ Calculating usage rates and reorder levels (*Section 6.3*).

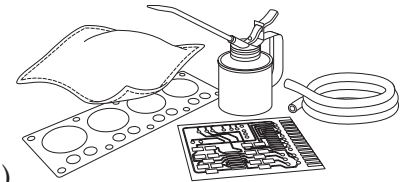

The procedures required for purchasing spare parts and maintenance materials are discussed in *Guide 3* on procurement and commissioning.

Some of this Section may appear similar to the discussion regarding tools (*Section 5.1*). The key difference is that spare parts and maintenance materials are recurrent items, are paid for from the recurrent budget, and are usually purchased at regular intervals.

6.1 GENERAL DISCUSSION ON SPARE PARTS AND MAINTENANCE MATERIALS

Besides spare parts and maintenance materials, maintainers will also need access to equipment accessories and consumables. Maintainers may need to use these items when testing and maintaining equipment, but they may also be responsible for their storage on behalf of the health service provider. The specific discussion on equipment accessories and consumables is provided in *Guide 4* on operation and safety. However, the discussion here on spare parts and maintenance materials covers similar issues of availability and storage procedures.

Health service providers must also ensure they supply maintainers with adequate safety gear needed to do their jobs, such as goggles, gloves, masks, overalls, and boots. In some health systems, these items are purchased as general supplies and paid for out of administrative costs (see *Guide 2* on planning and budgeting) and therefore are not strictly considered maintenance materials.

It doesn't matter which way you purchase this safety gear, as long as it is not forgotten. The advice offered in this Section is just as relevant for safety gear, and can assist you with its purchase, storage, and replenishment.

Availability

Equipment spare parts are those items which:

- ◆ are working components of a machine (switches, wheels, light bulbs, etc)
- ◆ are often internal parts (gears, bearings, printed circuit boards, etc)
- ◆ are subject to wear and tear (doors, gaskets, fan belts, etc)
- ◆ are often (but not always) specific to a particular machine and may possibly only be made by the equipment manufacturer.

For a piece of equipment to last for years, some spare parts will need to be replaced regularly, therefore spare parts must be available for the lifetime of the equipment.

Maintenance materials are those items which:

- ◆ are used up during the maintenance of the equipment (such as oil, grease, electric cable, washers, screws, fuses, paint, oxy-acetylene, etc)
- ◆ are more general and readily available from many sources.

Therefore, maintenance materials are needed for the lifetime of the equipment.

The availability of equipment spare parts and maintenance materials will dictate how long maintenance staff can keep a piece of equipment functioning. Once spare parts and maintenance materials are no longer available, a piece of equipment cannot be repaired even if it is fixable.

Equipment spare parts and maintenance materials are also required for planned preventive maintenance (PPM) which is activities aimed at keeping equipment safe by replacing parts before they break down. If spare parts and maintenance materials are no longer available, staff cannot keep the equipment safe or prevent breakdowns.

Finance

Your aim is for equipment to remain in a working condition, and be available to support your clinical workload. Thus, it is necessary for sufficient budgets to be calculated and allocated for the purchase of the required spare parts and maintenance materials. This cost will be relevant over the whole lifetime of the equipment. Thus, continually finding the money for these items will be a challenge throughout the life of the equipment. *Guide 2* on planning and budgeting provides guidance and procedures on budgeting for the maintenance costs of equipment.

Did you know?

The majority of the maintenance and repair workload is simple tasks requiring common spare parts.

Therefore, try to remember that more than 80 per cent of all spare parts needed (in theory), represent less than 20 per cent of the overall spare parts cost.

In other words, only 20 per cent of your maintenance and repair tasks can eat up 80 per cent of your spare parts budget, because the equipment is complex and expensive.

Because many equipment spare parts come from abroad, you will need access to foreign currency. Some organizations set up a 'revolving fund' to help with the continual purchase of equipment-related supplies (spare parts, accessories, etc), sometimes with assistance from external support agencies (donors) – see country experience box below



Experience in Kenya

The Ministry of Health (MOH) in Kenya (with GTZ support), set up a division specifically responsible for the supply of equipment spare parts. The supply programme was successful and comprised the following elements:

- ◆ *Stock requirements were determined from the equipment inventories of health facilities throughout Kenya. They were: spare parts based on about 20 items of basic medical apparatus found in government hospitals, installation materials, and raw materials (such as canvas for the repair of examination couches), and later expanded to certain building materials, and repair kits designed by the Maintenance Service. It was important only to stock what health facilities really needed, and to avoid 'dead stock'.*
- ◆ *The key to the success of the programme is the catalogue, which has been developed to reduce the problems of mis-ordering. Each item is numbered, carefully described, and illustrated where appropriate. The catalogue and price list are distributed to the senior administrator and technologist (in charge) at every health facility registered with the programme. Periodic updates, catalogue additions, and changes are sent out as required.*

Continued overleaf



Experience in Kenya (continued)

- ◆ *An office was established in Nairobi to undertake all procurement centrally. Four very secure stores were established around the country according to geographical criteria and population density. Each one is fully equipped with office equipment, furniture, storage shelving, and bins. The store-keeping is run by computer programs for: tracking supplies inventory, generating sales invoices to health facilities, compiling data for reports, tracking debtor information, tracking data from other stores, etc. It is important to monitor fast-moving items and avoid stock-outs – the biggest source of frustration for customers. A simple data transmission system was installed, reducing the need for long telephone calls and costly courier services. Customers organize their own transport for the delivery of purchased items. The programme has just a three-ton panel van for stock distribution, a small car for administrative trips within the capital, and a mini-bus for transporting personnel further afield.*
- ◆ *The purchase of the original stock was financed using foreign exchange contributions from both the Kenyan and German governments. They were procured overseas and locally, using official government procedures. All the money is held in a revolving fund – a separate account held by the MOH in the central bank. This fund, therefore, is not subject to the normal annual budgetary rules but can be drawn on at any time either in local or foreign currencies. The facilities requiring goods simply use purchase orders and are invoiced later. It is vital that goods are paid for promptly in order to perpetuate the revolving fund, so great attention is paid to recovery of late payments. It was necessary to try to keep running costs to a minimum, and set the price mark-up at a level which covers both inflation and overheads. Later on, sales were made available to mission and private hospitals at a higher mark-up. For accountability, security, and transparency, bi-annual stock-takes and annual independent audits take place, strict tender rules are followed, and staff are attached to the relevant Provincial Medical Office and not to the hospital where the store is located.*
- ◆ *In 1996, the programme employed around 26 government staff from various disciplines: an accountant, administrators, supplies officers, technicians, storekeepers, secretaries, typists, messengers, and a driver. The operating system was made as easy to use as possible for the calibre of staff available. Procurement, storage, and sales procedures are straightforward and make use of existing government systems. An external procurement agent is used for many standard items, and a computer software maintainer is also used. Specialist training of staff was provided at an early stage in the programme and is reinforced regularly, and job-sharing and flexibility within the teams is encouraged.*

Procurement Issues

Different brands of spare parts and maintenance materials are not necessarily interchangeable and cannot always be used with all makes and models of equipment. Therefore it is vital, when ordering equipment, to specify the particular and exact requirements for your spare parts and maintenance materials (see *Guide 3* on procurement and commissioning). For each spare part, you need to provide as much of the following information as possible:

- ◆ The name of the manufacturer of the equipment.
- ◆ Make, model, and year of manufacture of the equipment that the part is for.
- ◆ Serial number of the equipment.
- ◆ A full description of the part required (try to use the description and names used in the manufacturer's manual or order catalogue).
- ◆ Size, rating (volts, watts, etc), and material.
- ◆ Quantity and pack size required.
- ◆ Manufacturer's order number for that part and quantity.

When buying new equipment, you can try to rationalize your spare part and maintenance material stock. You achieve this by buying equipment which makes use of the types of spare parts and maintenance materials which you already keep in stock. This would be the most efficient use of your stock of supplies, and is an important reason for standardizing the equipment you buy to a small number of makes and models (*Section 2.1*). Also, spare parts and maintenance materials bought in bulk are often cheaper.

For most countries, the procurement of equipment spare parts from abroad is a lengthy and tedious process. It takes time to obtain quotations, secure foreign currency, and ship goods. If you want to retain stock levels and receive items on time, you must plan ahead for items procured from abroad.

Items procured locally (the majority of maintenance materials) should not pose such problems, as long as funds are available. They can be obtained from local suppliers or from a body such as a central stores. The HTM Working Group may want to develop a policy to purchase equipment, spare parts, and maintenance materials locally where possible, in preference to overseas, to encourage the development of sustainable local markets.

The HTM Working Group, or its smaller stock sub-group (*Section 1.2*), should develop procedures for comparing products, and reviewing their cost and performance before reordering them, to avoid the purchase of items known to be poor. Purchasing should be a process without political or social influence to avoid possible allegations of bribery. You should also have a policy of only accepting free gifts if they come with a stock of spare parts, so that you can maintain the equipment (see *Guide 3* on procurement and commissioning).

The quality and effectiveness of a repair job is often jeopardized by the use of low quality parts and materials. Poor parts and materials may break if they are not strong enough, they may fail earlier than expected, or they may rub, corrode, or in some way damage other parts of the machine. Even if you do a first class repair job:

- ◆ poor quality engine oil means the engine will not last as long as it should
- ◆ poor quality batteries affect the performance of the equipment, have a short life, and leak
- ◆ poor tyres compromise the safety of a vehicle
- ◆ poor quality solder evaporates or cracks easily
- ◆ poor gaskets and seals leak, or perish quickly.

Cost and quality often go together. Equipment manufacturers' own brand of spare parts and maintenance materials often produce better results than 'lookalikes'. Many companies are set up solely for the purpose of manufacturing lookalikes – these products are often (but not always) cheaper, but may be of inferior quality. We recommend that, as the items get more technically complex or critical, you should try and buy better quality spare parts and maintenance materials. A discussion on sourcing and obtaining good quality products can be found in *Guide 3* on procurement and commissioning.

In your country, there may be other supply routes which could help your health service provider to obtain high quality supplies. For example:

- ◆ Your country may have a booming electronics or automotive industry which could help with the sourcing, import, distribution, and storage of good quality electronic or automotive components.
- ◆ Sometimes, church or mining health sectors can be more flexible than government ones in their procurement practices. Thus, it will be useful for different health service providers to collaborate and do business with each other.

Quantities to Buy

Many spare parts and maintenance materials have a shelf-life:

- ◆ Items with an expiry date.
- ◆ Items affected by heat.
- ◆ Items which rust or collect condensation.
- ◆ Items which deteriorate, such as batteries.

Shelf-lives will:

- ◆ affect your ability to buy in bulk
- ◆ affect your ability to buy well in advance
- ◆ require you to provide good quality storage facilities (*Section 6.2*)
- ◆ require you to have an effective stock control system, to ensure that you conform to the rules for stocks with shelf-lives – SLFO (shortest life, first out) and FIFO (first in, first out) principles (*Section 6.2*).

Thus, where possible, you should use centralized purchasing and storage arrangements as these are more economical and ensure a good turnover of stock. The quantities that you decide to buy (*Section 6.3*) also depend on the ‘lead-time’ for each item (the time taken for goods to arrive once ordered).

When purchasing new equipment and funds are available, it is a good idea to purchase a supply of spare parts, accessories, and consumables at the same time. Consider purchasing enough for a set period, such as a two-year supply (see *Guide 3* on procurement and commissioning).

Manufacturers’ manuals, their local representatives, and suppliers can often provide information and advice about the likely consumption rates of the items you require, and this may help you decide on the quantity to order.

6.2 STORAGE SYSTEM AND PROCEDURES

Elements of the Storage System

Your health service provider will need to decide where equipment spare parts and maintenance materials are stored. There are a number of options depending on:

- ◆ the size of your Healthcare Technology Management Service (HTMS)
- ◆ the location of the maintenance workshops and HTM Team premises
- ◆ the supply and distribution system
- ◆ the storage system used by the health service for other supplies
- ◆ the skills and trustworthiness of your staff.

What is important is that someone takes responsibility for these maintenance items. Options are:

- ◆ First, decide whether to include them with all other general and medical supplies in the health service storage system, or separate them out and place them in an HTMS storage system.
- ◆ Then use your normal distribution system, and store different quantities at:
 - the central level
 - the district/regional level
 - the health facility store or maintenance workshop store.
- ◆ Finally, decide whether the people looking after the stocks are going to be either trained stores personnel or maintenance staff. Whatever you decide, the individuals should be given training on how to run the stock control system.

Different countries and health service providers find different solutions to this dilemma. The most important issue is that you choose a flexible system which ensures that:

- ◆ the person in charge of the stores (at every level) is trustworthy
- ◆ there is a proper stock control system
- ◆ maintainers have easy access to the items they need whenever they need them (without abuse of the system)
- ◆ the people running the stores are familiar with the items they order and issue.

Remember that you also have responsibility for other equipment-related items, such as accessories and consumables. A similar discussion for these items is provided in *Guide 4* on operation and safety. The HTMS storage system may end up being responsible for all equipment-related items.

Whether you decide to turn maintenance staff into storespersons, or use the professional skills of existing stores personnel depends on:

- ◆ the knowledge of the staff
- ◆ their recognition of the range of spare parts and maintenance materials
- ◆ whether the stores are holding bulk quantities or only those for daily/weekly use
- ◆ whether you need access to the supplies for out-of-hours emergencies.

It is common for general stores staff to have a problem with recognizing the wide range of equipment-related supplies in stores, and this can lead to a number of problems such as non-issue, loss, and incorrect ordering.

It is vital that you train stores staff and procurement officers to recognize equipment-related items.

There needs to be some mechanism to control when spare parts are replaced and maintenance materials used, to avoid abuse of the system. For example, this needs to avoid batteries being replaced early and the old ones being used at home, car parts being substituted unnecessarily and sold off privately, and paint being used in people's homes.

Box 23 provides some strategies for all these issues.



Country Experience

In one country, such things as parts on motor vehicles are labelled to ensure that they remain secure when vehicles are sent to private workshops for servicing and repair. The aim is to prevent the parts being swapped for inferior quality items. Tyres in particular are marked in this way.

BOX 23: Strategies for Storing Equipment-Related Items

Strategy	Suggestions
If you decide to use a general health service store for the majority of the stock, designate a separate section where all equipment-related items can be stored together	This separate section would contain equipment, spare equipment accessories, equipment consumables, equipment spare parts, and maintenance materials. In this way, it is possible to ensure that the small quantities of many varied technical items do not go missing and unrecognized among the bulk of general items kept in the stores.
Allow your workshops to have a sub-store for weekly/regular and special requirements	Maintenance staff are more likely to recognize equipment spare parts and handle them correctly than general stores staff. Also, they need access to the parts in out-of-hours emergencies when the central store is closed. Therefore, train them to use the correct stores stock control system on the smaller quantities kept in a secure maintenance sub-store.
Ensure that the correct technical item is used for the correct application	<p>There are various possibilities:</p> <ul style="list-style-type: none"> ◆ All equipment spare parts could be issued only with the signature of an HTM Manager or his or her deputy. ◆ If there is any uncertainty concerning which is the correct part to be issued/used for a certain application, seek the advice of the HTM Manager, or consult the equipment manual. (In the case of accessories and consumables, the relevant Head of the User Department could be consulted.) ◆ The old part should be returned to the HTM Manager for inspection and disposal.
Any store should have an identification code system for the items in stock	<p>If such a system already exists for general and medical items, it can be extended to cover equipment-related supplies. Some equipment items will be covered by relevant codes for existing categories, and some will require new ones to be set up. For example, there will usually be:</p> <ul style="list-style-type: none"> ◆ an existing code for surgical items, etc ◆ an existing code for hardware, which could cover spare parts and maintenance materials ◆ an existing code for fuel and lubricants, which will cover some maintenance materials ◆ a new code required for equipment accessories ◆ a new code required for equipment consumables ◆ any new code as required.
Develop an illustrated catalogue	This should show equipment-related items with descriptions and photographs or drawings, together with their stores code.
Use a proper stock control system	This ensures that you use some form of Stock Card in order to keep track of the stocks ordered and issued (see below).
Ensure work orders clearly show the supplies required	In this way, you can check the amount and rate of use of supplies against the stock left at the time of the annual audit.

The storage system (at any level, such as a hospital) may have a main store which stocks the major bulk of all items, but which issues weekly/regular requirements to smaller sub-stores in the maintenance workshop or user-departments. The items issued to the sub-stores will depend on the value and frequency of use of each item.

A workshop (or user-department) is allowed a sub-store when:

- ◆ they have a secure, lockable storage room
- ◆ it is agreed which are the regular items required on a daily/weekly basis for storage in the department
- ◆ the Stores Controller provides the workshop with the necessary stores forms to complete
- ◆ the Stores Controller trains a suitable staff member from the workshop to correctly fill in the necessary stores forms for the stocks held in the workshop
- ◆ the workshop has special storage requirements (spare parts of a delicate nature, for example), so the Stores Controller allows bulk stores to be held outside the main stores under agreed special conditions, as long as they are secure.

Box 24 provides some strategies for creating a suitable secure and clean store which is organized in a simple and logical way.



Experience in El Salvador

The Maintenance Department of the Public Health Service in El Salvador established their central store, and regional and local sub-stores, with support from German Technical Aid. All their equipment-related supplies are given codes which are linked to their equipment inventory coding system. Their storage space is divided according to the inventory codes, and the shelves are divided and labelled accordingly. In this way, supplies common to individual pieces of equipment are kept next to each other. In addition, their inventory coding system included codes for families of equipment/areas of use (such as radiographic equipment, suction equipment, heating and ventilation equipment); in this way, supplies for individual machines are stored in the same area as supplies for other machines in the same equipment family. In order to make the stock control system faster and more efficient, they developed a computerized system (with support from Dutch Aid).

BOX 24: Strategies for Creating Suitable Store Rooms

Space	<ul style="list-style-type: none"> ◆ Provide a space which is secure, clean, dry, free from pests, not too hot or cold, well-ventilated, and not exposed to direct sunlight. ◆ Provide enough space to store all the equipment-related supplies and materials on shelves, in cupboards, or in containers such as bins. ◆ If no shelving is available, make your own shelves using planks of wood supported on bricks or crates. ◆ Make use of the space in the middle of the room for shelves – putting shelves only around the walls takes up a lot of space and wastes the space in the middle of the room.
Organization	<ul style="list-style-type: none"> ◆ Organize the store in a simple and logical way so that items can be found quickly and easily. ◆ Organize the stock into different sections for different categories of supplies: in other words, cluster items by their application. ◆ Code each row, block, shelf and bin, in order to identify the location of each part. ◆ Clearly label each section of the store, allocate each item to a specific place and label the position of the item on the shelf so that it is easy to read. ◆ Provide every bin and shelf partition with a stock card.
Monitoring	<ul style="list-style-type: none"> ◆ Monitor stock movements, either through a paper record system or using a computer program. ◆ Rotate stocks according to their expiry date: <ul style="list-style-type: none"> - Use the SLFO (shortest life, first out) and FIFO (first in, first out) rules, and store items that have the latest expiry date at the back and items with the earliest expiry date at the front. - Use the FIFO rules for items without an expiry date and mark these with the date of receipt. ◆ Put a red star or a similar mark on the labels of all items that have an expiry date within the current year. ◆ Remove expired, damaged, or obsolete items from the shelves and dispose of them according to approved waste management procedures (see <i>Guide 4</i>).

What to Keep in Stock

Most stores systems have what are known as ‘stockable’ items: these are items which are automatically replenished when stocks run low, and are therefore always in stock. This is a common system for medical and general items, but is rarely in place for equipment-related supplies and this makes it very difficult to keep equipment functioning. You should therefore aim to make equipment-related items stockable too, including:

- ◆ equipment consumables
- ◆ commonly-used accessories
- ◆ the spare parts and maintenance materials required for PPM
- ◆ those parts and materials which experience tells you will be required for common repairs.

Less commonly used equipment-related items may remain as non-stockable items.

How the System Works

Usually, the Stores Controller monitors the stock levels of stockable items and, when stocks are running low, submits order forms to the Purchasing and Supplies Officer to automatically buy in another batch.

However, if a stockable system has not yet been established for equipment-related items (perhaps because funding for the health service is unstable), recurrent items are considered for purchase each month or quarter, when cash is available. In this case, the workshop submits its order for further supplies to the Purchasing and Supplies Officer (as described in *Guide 2* on planning and budgeting) – see *Annex 9*.

In addition, workshops submit their orders for non-stockable items to the Purchasing and Supplies Officer, as and when they are required.

Keeping Track of Stocks

Whenever new equipment-related supplies arrive, they should be entered into the stores system. Also when new equipment arrives, the stocks of spare parts, etc that were purchased with it should be entered by the Commissioning Team into the Stock Control system (as described in *Guide 3* on procurement and commissioning) – see *Annex 8*.

Stores staff should:

- ◆ allocate code numbers to the different equipment spare parts and maintenance materials
- ◆ enter onto the **Stock Cards** (bin cards) the sorts of information that is shown in *Figure 19*. Guidance on the stock levels required can be sought from the HTM Manager, and information generated from a one-off exercise (as described in *Section 6.3*)
- ◆ store the new supplies on labelled shelves with their stock cards (bin cards)
- ◆ issue a list of the codes for specific items to the HTM Teams (and relevant departments undertaking user PPM), so that they can easily identify and order items (for example, a spare rotor blade for suction pump Type A may have code number HA 07 100).

Figure 19: Sample Stock Card (Bin Card)

Stock Card (Bin Card)						
Item description:					Card no:	
Unit/pack size:			Cost:		Item code no:	
Maximum level:			Minimum/Reorder level:		Location:	
Reserve stock level:			Order quantity:		Lead time:	
Date	Received from/ issued to	No. received	No. issued	New balance	Remarks	Signature

If the workshop has a sub-store, the staff in the main store can consult with the HTM Manager, and issue the short-term requirements to the sub-store every week (or month). The Stores Controller then monitors the usage rate of stocks in the sub-store to ensure that the workshop doesn't request too much for its regular issues, and ensures that the workshop is only issued with what it really needs.



- Tip**
- The stores system described in *Sections 6.2 and 6.3* assumes that the Stores Controller is a senior member of staff with a good understanding of the stock control system, who is used to reviewing usage rates and identifying any irregular trends compared to normal requirements.
 - If your Stores Controller is a junior member of staff without these skills, the HTM Manager may need to help with determining suitable stock levels, monitoring usage rates, and prompting reorders.

As goods are issued and marked off on the stock card, the record system tells the Stores Controller when the stocks are low and the reorder level has been reached. Then:

- ◆ in the case of non-stockable equipment-related items, the Stores Controller prompts the workshop staff to complete an order form requesting further supplies
- ◆ in the case of stockable equipment-related items, the Stores Controller writes a purchase order for approval by the Health Management Team and submits it to the Finance Officer for payment.

The stores stock control system can be a manual paper system or a computerized system. It doesn't matter which you use, because the sort of data that you must record is the same whether you are designing the layout of a card or the fields on your computer screen. Also, any computer system involves an element of paperwork, as standard forms can be printed out for stores staff and workshops to fill in.

The rest of this Section covers paper forms, and various manual ways to summarize the data. If your health service provider has a computerized stores' stock control system, this can automatically generate purchase orders when reorder levels are reached. Stock management is an area in which simple computer systems have proved to be quite valuable (see *Annex 2*).

6.3 CALCULATING USAGE RATES AND REORDER LEVELS

When stocks of equipment spare parts and maintenance materials decrease, levels must be replenished. Thus it is necessary to monitor and control the stock of spare parts and maintenance materials, in order to ensure that you always have the required items in stock on the shelves when they are needed. To achieve this, the Stores Controller needs to know when to reorder goods and how many should be reordered. A number of factors will affect these calculations for different types of items:

- ◆ The rate of use of each item (for example, six per week, two per month). This will be affected by the frequency of timetabled PPM work, planned remedial work, planned site preparation and installation work, and the likely breakdown rate (life of a part) estimated from past experience and records.
- ◆ The lead-time for each item (that is the time taken for goods to arrive from the supplier or central stores once ordered).
- ◆ How often you can place orders (the frequency of ordering).
- ◆ The cost of each item.
- ◆ The shelf-life of the item.

First, you will need to identify what is worth holding in stock, how much is required, and where it should be placed in your stores chain, based on the type of maintenance and repairs you undertake. Secondly, it is necessary to continually restock so that you always have sufficient items to carry out the necessary work. This calculation is based on rates of consumption. The following sub-sections discuss how to do this.

Annual Requirements: What to Have in Stock

First of all, the HTM Teams need to get an idea of how much of each type of spare part/material they are using (the discussion on accessories and consumables is covered in *Guide 4*). If such goods have not been stockable items up to now, there will be little information currently on stores' stock cards from which the Stores Controller can make these calculations. Thus, for existing equipment, you may need to carry out a one-off exercise to identify the type of spare parts and maintenance materials required, the quantities used, their sources, and possible prices (see *Guide 2* on planning and budgeting).

The HTM Working Group can nominate a smaller stock sub-group (*Section 1.2*) to undertake this one-off exercise, the findings of which will be based on the experience and identified needs of the HTM Manager for the area covered by his or her team (for example, a health facility, a district).

Guide 2 describes how the information collected can be used to calculate more realistic maintenance budgets. The information should also be given to the Stores Controller for entry onto the stock cards, so that there is sufficient data on usage rates, reorder levels, and reorder times for equipment spare parts and maintenance materials.

In the case of new equipment purchases, a well documented list of the spare parts supplied should be entered into the stores system automatically during the equipment Acceptance Process (as described in *Guide 3* on procurement and commissioning) – see *Annex 8*.

You will need to decide the following:

- ◆ What types of supplies do you need? (What do you commonly use? What is worth holding in stock?).
- ◆ What quantities of each item should you order? (How much do you need to have available for use?).
- ◆ Which items are the most important to keep in stock? (Is the part/material essential? Will the equipment continue to work without the part being replaced? Is someone available who has the skills, time and tools to fit the part?).

You will need to order large quantities of items that are frequently used, and fewer of items that are only used occasionally. It is preferable not to stock items that are rarely used, since it is not good to tie up your money in stocks that sit on shelves for years doing nothing.

Ordering too little (understocking) results in shortages: your health facility will be unable to provide effective treatment and care as a result, and staff and patient confidence in the service will be undermined. Ordering too much (overstocking) results in a build-up of stock and wastage (of items that are not used before their expiry date, for example, or that become spoiled if left unused for too long) as well as tying up valuable funds unnecessarily.

The quantity of replacement spare parts and maintenance materials that you order depends on factors that you can anticipate, such as:

- ◆ how much stock is normally used
- ◆ how much work is planned or can be expected
- ◆ seasonal demands
- ◆ how often you place an order
- ◆ the storage capacity of your store.

6.3 Calculating usage rates and reorder levels

You may also need to order a limited quantity of extra stocks of some items so that you can deal with unexpected events.

First of all, you need to decide the number and type of spare parts and maintenance materials to own and stock. This depends on the likely life of the item, the number of machines of the same type that you look after, and budget constraints. There are several things to consider, and *Box 25* provides the basic calculations required to work out how much you should own.

Remember, these calculations will have to be done for every type of spare part and maintenance material, for each type of equipment that you maintain and repair.

BOX 25: Steps for Calculating Annual Requirements of Spare Parts and Maintenance Materials

Step 1. Consider the Lifetime of the Spare Part or Maintenance Material	
<i>Consider</i>	<i>Example</i>
You need to know how long the part or material will last. Some parts have a long life, some parts are replaced frequently, and many materials are used up as you undertake your repair work, as follows:	
<p>a. Spare parts required for unpredictable work, such as repairs. You consider the likely life of the part (how long it will last before it fails), and how many machines you need that part for. You assume that all similar parts will not fail at once, and stock a few of them to cover possible failures among a group of machines over time.</p>	You do not buy a spare motor for every suction pump every year, but stock a small quantity of motors to cover possible breakdowns among all your suction pumps over several years.
<p>b. Spare parts required for planned work, such as PPM, and known remedial or installation work. You consider the rate of use of the part, and stock the actual number of parts that you know you will need to replace at set intervals.</p>	You know how often you must replace a suction pump filter, and how many suction pumps you own. Therefore you stock the right amount of filters each year to enable you to undertake the necessary replacements.
<p>c. Consumable maintenance materials. These are used up as you undertake maintenance and repair work, so you need to calculate the consumption rate (this depends on how busy you are and your rate of use). How much you buy will also depend on the pack size for these products.</p>	Suction pump tubing is supplied in rolls of several metres. Oil may come in 1 litre bottles, or 50 litre containers. Grease may come in 100g tubes, or vast tubs.

Continued opposite

BOX 25: Steps for Calculating Annual Requirements of Spare Parts and Maintenance Materials (continued)

Step 2. Calculate Quantities	
<i>Consider</i>	<i>Example</i>
<p>For each equipment type, identify only the parts usually required that you really need.</p> <p>You need to know the life of the part (in years), how often it is used, or its consumption rate. In addition, you need to know the number of similar machines you are maintaining and stocking parts for.</p> <p>Use the following calculation:</p>	<p>For example:</p> <p>You have 20 kerosene refrigerators; $N = 20$.</p> <p>You need the following replacement parts:</p> <ol style="list-style-type: none"> 1) The fuel tank (spare part A) may have a life of seven years; $L_A = 7$ (years) 2) The door seal (spare part B) may have a life of three years; $L_B = 3$ (years) 3) The wick (spare part C) may last six months; $L_C = 0.5$ (years)
<p><i>Quantities according to the lifetime of the part and the number of machines responsible for</i></p> <p>Find out how many similar machines you are responsible for [number of machines = N].</p> <p>This type of information can be obtained from your equipment inventory (see <i>Guide 2</i>).</p> <p>Also find out the life of the part (in years), or how quickly it is used up [life of item $Z = L_Z$].</p> <p>This type of information can be obtained from the manufacturer, their manuals, your experience, planned replacements in your PPM schedules, or the number you know you use each year.</p> <p>Then calculate the quantity used as follows:</p> <p>Quantity of part Z needed per year, [Quantity$_Z$]</p> $= \frac{\text{Number of machines}}{\text{Life of item } Z \text{ (or rate of use)}} = \frac{N}{L_Z}$	<p>In the examples above:</p> <ol style="list-style-type: none"> 1) Quantity of fuel tanks needed each year [Quantity$_A$] = $20/7 = 3$ (rounded up to a whole number) 2) Quantity of door seals needed each year [Quantity$_B$] = $20/3 = 7$ (rounded up to a whole number) 3) Quantity of wicks needed each year [Quantity$_C$] = $20/0.5 = 40$

Continued overleaf

BOX 25: Steps for Calculating Annual Requirements of Spare Parts and Maintenance Materials (continued)

Step 3. Calculate Costs	
<i>Consider</i>	<i>Example</i>
<p>For each part you have calculated that you need, you must establish what it will cost. Use the following calculations:</p>	<p>From the example in Step 2 above:</p> <ol style="list-style-type: none"> 1) The fuel tank (spare part A) costs US\$ 100; $C_A = 100$ 2) The door seal (spare part B) costs US\$ 25; $C_B = 25$ 3) The wick (spare part C) costs US\$ 5; $C_C = 5$
<p><i>i) Costs according to the quantity of a part needed for a particular type of machine, and its price</i></p> <p>Find out the quantity required for each item [quantity of item Z = Quantity_Z]. This was calculated in Step 2 on the previous page.</p> <p>Also find out the cost of the part (in one unit of currency) [cost of item Z = C_Z]. This type of information can be obtained from the manufacturer, their representative, their catalogue, or local suppliers.</p> <p>Then calculate the total cost for each part for one year as follows:</p> <p>Total cost for part Z for one year, [Total cost_Z] = Quantity of part Z x Cost of part Z = Quantity_Z x C_Z</p>	<p>In the examples above:</p> <ol style="list-style-type: none"> 1) Total cost of fuel tanks for one year [Total cost_A] = 3 x 100 = US\$ 300 2) Total cost of door seals for one year [Total cost_B] = 7 x 25 = US\$ 175 3) Total cost of wicks for one year [Total cost_C] = 40 x 5 = US\$ 200
<p><i>ii) Overall cost according to all the parts required, for all machines</i></p> <p>Having found out the total cost required for each item [total cost of item Z = Total cost_Z], you need to find the overall cost of all parts required, for each equipment type you maintain.</p> <p>Then calculate the overall cost for all parts for one year, as follows:</p> <p>Overall cost required for the year, [OC] = Total cost_A + Total cost_B + Total cost_C + so on</p>	<p>In the examples above:</p> <p>Overall cost of the parts required for 20 kerosene refrigerators [OC] = 300 + 175 + 200 = US\$ 675</p>

Continued opposite

BOX 25 Steps for Calculating Annual Requirements of Spare Parts and Maintenance Materials (continued)

Step 4. Adjust Quantities According to Your Budget	
<i>Consider</i>	<i>Example</i>
<p>Is your maintenance budget large enough to purchase all the parts required? If it isn't, how will you reduce the quantities you can buy of each item? Use the following calculations:</p>	<p>From the example in Step 3 on the previous page: The overall cost of all the parts required for 20 kerosene refrigerators for one year [OC] = US\$ 675 The budget available to you for these parts [B] = US\$ 500</p>
<p><i>i) The reduction factor required to reduce the number of parts you buy to a number you can afford</i></p> <p>If the overall cost [OC] of parts is greater than your budget [B], you will need to reduce the quantities you buy. So you determine the reduction factor, as follows: The reduction factor [RF] you require = $\frac{\text{Budget}}{\text{Overall cost}} = \frac{B}{OC}$</p>	<p>In the example above: The overall cost of US\$ 675 is > the budget of US\$ 500 Thus, the reduction factor [RF] required = $\frac{500}{675} = 0.74$ (round the figure down to a smaller number)</p>
<p><i>ii) Actual quantities you can afford</i></p> <p>Having found out the reduction factor [RF], you need to apply it to the quantity of each part [Quantity_Z] calculated in Step 2. Thus, you calculate the actual quantity of each part that you can afford, as follows: Actual quantity of part Z that you can afford, [Actual Qty_Z] = Quantity_Z x RF</p>	<p>In the examples above:</p> <ol style="list-style-type: none"> 1) Number of fuel tanks you can afford [Actual Qty_A] = 3 x 0.74 = 2 (number rounded down) 2) Number of door seals you can afford [Actual Qty_B] = 7 x 0.74 = 5 (rounded down) 3) Number of wicks you can afford [Actual Qty_C] = 40 x 0.74 = 29 (rounded down)
<p><i>iii) Recalculate the total cost to ensure it does not exceed your budget</i></p> <p>Having found out the reduction factor [RF], you can apply it to the cost of each part [CZ] from Step 3 on the previous page. Thus, you calculate the reduced overall cost for all parts for one year to ensure you are now within your budget, as follows: Reduced overall cost [ROC] = Reduced cost_A + Reduced cost_B + Reduced cost_C + so on = (Actual Qty_A x C_A) + (Actual Qty_B x C_B) + (Actual Qty_C x C_C) + so on</p>	<p>In the example above: The reduced overall cost [ROC] = (2 x 100) + (5 x 25) + (29 x 5) = 200 + 125 + 145 = US\$ 470. This is within the budget of US\$ 500</p>

Continued overleaf

BOX 25: Steps for Calculating Annual Requirements of Spare Parts and Maintenance Materials (continued)

Step 4. Adjust Quantities According to Your Budget (continued)	
<i>Consider</i>	<i>Example</i>
<p><i>iv) Implications</i></p> <p>The reduced quantity of parts purchased will not last all year.</p> <p>You can calculate how long they will last (in months) as follows:</p> <p>Time reduced parts will last = 12 months x RF</p>	<p>In the example above:</p> <p>Time reduced parts will last = 12 months x 0.74 = just short of nine months</p>
<p><i>v) Response</i></p> <p>You can either:</p> <ul style="list-style-type: none"> ◆ Attempt to get more money to buy the parts you need for the whole year, and use these calculations to justify your arguments. ◆ Attempt to get more money to make a second order later in the year. <p>IMPORTANT: You should not cut back on the types of parts or quantities of parts that you know to be essential.</p>	

Having decided the type and quantity of parts to stock, there are other considerations to think about when ordering parts. The HTM Service needs to decide who should keep the stocks of different types of parts, and how many of each should be located at different types of stores in the supply chain. This depends on the following:

- ◆ **The cost of the part**
If a part is expensive, it is usually not possible to supply it to every place that may need one. Also, if the part is valuable it is more likely to disappear.
- ◆ **The local ability to fit the part**
If there is nobody trained to fit a part, there is little point in supplying the part to that location for storage.
- ◆ **The reliability of the person keeping the parts**
If the person responsible for storage of spares in a health facility or workshop is not able to keep spares safely, he or she should only be supplied a minimum number of parts for immediate needs.

There is no exact way of determining the correct place to keep a part – it is a matter of judgement. However, *Box 26* shows an example of how to decide how many parts should be kept where.

BOX 26: How to Calculate How Many Parts Should be Stocked Where

Step 1. Who Should Keep Parts?				
<p><i>The information you require is:</i></p> <ul style="list-style-type: none"> ◆ The cost of the part. ◆ The local ability to fit the part. ◆ The reliability of the person keeping the parts. <p><i>The calculation required is:</i></p> <p>i) For each spare part:</p> <ul style="list-style-type: none"> ◆ decide if the cost is high, medium, or low ◆ decide if there would be difficulties installing each part at the health facility level, district workshop level, or central workshop level ◆ as a result of this, decide where the bulk of each type of part should be kept. Use a table like the one in the example below, if it helps. <p><i>Example for a kerosene refrigerator:</i></p>				
<i>Part</i>	<i>Cost</i>	<i>Difficulty of installation</i>		
		<i>Health facility</i>	<i>District</i>	<i>Centre</i>
<i>fuel tank</i>	<i>high</i>	<i>high</i>	<i>medium</i>	<i>low</i>
<i>door seal</i>	<i>medium</i>	<i>medium</i>	<i>low</i>	<i>low</i>
<i>wick</i>	<i>low</i>	<i>low</i>	<i>low</i>	<i>low</i>
<p><i>On the basis of the example in this table, you may decide to keep:</i></p> <ul style="list-style-type: none"> ◆ <i>the fuel tanks at the central store</i> ◆ <i>the door seals at district workshop stores</i> ◆ <i>the wicks at health facility stores.</i> <p>ii) Then, you should:</p> <ul style="list-style-type: none"> ◆ check to see if you think there is a person responsible to keep these parts at these levels ◆ be prepared to revise your plans if necessary. 				
Step 2. How Many Parts Should be Kept at Each Location?				
<p><i>The information you require is:</i></p> <ul style="list-style-type: none"> ◆ Decide where (what level of the supply chain) most of the parts should be kept (as in Step 1 above). ◆ The total number of each part that you have [quantity] which need to be spread around your supply chain. ◆ The number of levels in your supply chain (for example, facility level, district level, central level). ◆ The number of stores at each level. <p><i>From the example above:</i></p> <ul style="list-style-type: none"> ◆ <i>You have 200 wicks = quantity.</i> ◆ <i>They will be kept at the health facility level.</i> ◆ <i>Your supply chain has three levels (facility, district, central).</i> ◆ <i>There is one central store, five district stores, and 25 health facility stores (see diagram overleaf).</i> 				

Continued overleaf

BOX 26: How to Calculate How Many Parts Should be Stocked Where (continued)**Step 2. How Many Parts Should be Kept at Each Location? (continued)**

The calculation required is:

i) For each spare part:

- ◆ You have already decided where the bulk of the spare parts should be kept (see Step 1 above).
- ◆ Now you must keep some reserve stocks at every level 'higher up' your supply chain.
- ◆ To do this, take a quarter of the parts that you have and put them at each of the levels higher in the chain.

From the example above:

The bulk of the wicks will be placed at the health facilities, and reserve stocks are required at the district and central stores, as follows:

Amount of wicks to be placed at the district level = $0.25 \times \text{quantity} = 0.25 \times 200 = 50$

Amount of wicks to be placed at the central level = $0.25 \times \text{quantity} = 0.25 \times 200 = 50$

The remaining wicks to be placed at the health facilities = $200 - (50 + 50) = 100$

ii) Then, you should:

- ◆ Divide the number of parts at each level, by the number of centres at that level:

From the example above:

Amount each of the 25 health facilities will have = $100/25 = \text{four wicks at each health facility store}$

Amount each of the five district workshops will have = $50/5 = 10 \text{ wicks at each district store}$

Amount of wicks the central store will have = $50/1 = 50 \text{ wicks at the central store.}$

This is illustrated by the diagram below.

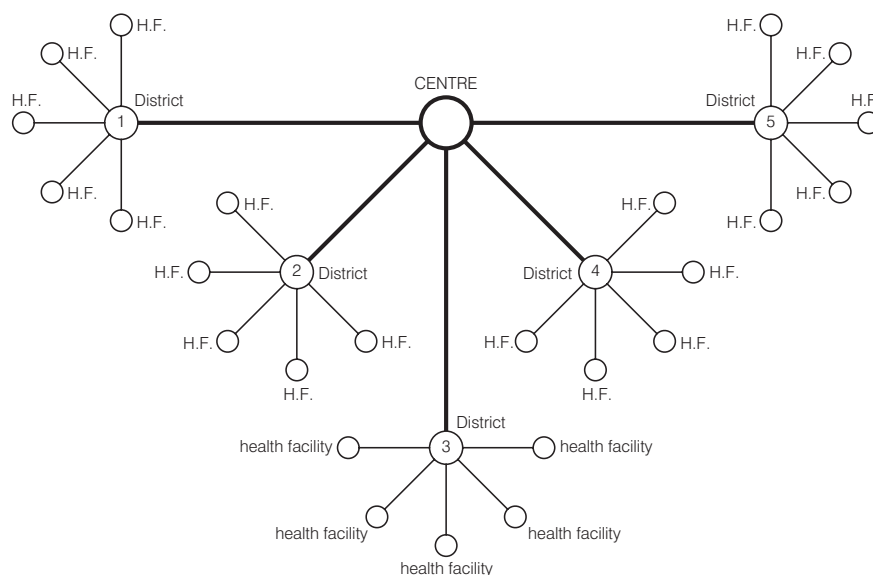

Source: WHO, 1985, 'Technician's handbook for compression refrigerators: Part D: How to keep stocks of spare parts', Logistics and Cold Chain for Primary Health Care Series No.20, Geneva, Switzerland, EPI/LOG/84/20, EPI/TECH.HB/D

Once the HTM Service has calculated the sorts of parts and materials they should be storing, and where in the HTMS network they will be placed, then they can be entered in the storage system for equipment spare parts and maintenance materials (Section 6.2).

Regular Monitoring: When to Restock

Once the equipment spare parts and maintenance materials are in store with stock cards, the stores staff can record the weekly issue quantities, and monitor the workshop usage rate.

Other types of information need to be filled in on the stock cards (see *Figure 19*). This data covers issues such as:

- ◆ when to reorder
- ◆ how much to reorder
- ◆ how long the delivery time is
- ◆ how low stocks can fall.

Box 27 shows you how to calculate the data that should be put on each stock card. From experience over time, the Stores Controller should be able to help you to calculate this data.

The purpose of recording this information on the stock cards, is so that the stock control system will prompt you when it is necessary to buy more stocks. Then the Stores Controller can automatically order the items to ensure that you do not run out of the materials you require for the work of the HTM Team.

Once a month the information on the stock cards is transferred to a **Stock Control Ledger** (stores record book). It is simpler to make an order using the summary in the stock control ledger than using all the individual stock cards. The stock control ledger is also a useful tool for analyzing stock management and reviewing the accuracy of stock levels.

A stock control ledger (stores record book) should be kept by every workshop store in order to keep track of the quantities of spare parts and maintenance materials used and kept in stock. The workshop's storesperson should be responsible for keeping these records. You can either obtain a stock control ledger from your Health Management Team or make one yourself, using a separate page to keep records for each type of item. *Figure 20* shows two different sample layouts for the ledger.

BOX 27: How to Calculate Reordering Times and Quantities

Supply Term Definition	Principle	Calculation	Examples
Time Between Orders [TBO] – supply period, which reflects your frequency of ordering	In some organizations, you must place orders according to a regular schedule. In others, you can order supplies at any time, as and when you need them.	Look at your records/regulations and work out how often you can place an order, for example, once a year, once a quarter, or once a month. Express this in months.	For example, assume: a. o-rings are ordered once a quarter, thus TBO = 3 b. bearings are ordered once a year, thus TBO = 12
Lead Time [LT] – delivery time.	This will depend on the distance, transport, and supplier/sources involved, and will vary from item to item.	Look at your records and work out the time between placing an order and receiving it. Express this in months.	In examples above, assume: a. the LT for o-rings is 1 month b. the LT for bearings is 6 months
Average Monthly Consumption [AMC] – average quantity of an item issued/used each month.	This is calculated over a period of months to take account of seasonal variations in demand.	Look at your records and work out: $AMC = \frac{\text{total quantities issued/used in a time period}}{\text{number of months in that time period}}$	In examples above, assume: a. 3,000 o-rings are used in 6 months, thus AMC = 3,000/6 = 500 b. 48 bearings are used in a year, thus AMC = 48/12 = 4
Reserve Stock [RS] – safety or buffer stock, in other words, the lowest level of stock for each item.	Quantities should not be allowed to fall below this level. It is the extra supplies required to ensure there are no ‘stockouts’ when there is an unexpected increase in demand, or a delay in receiving supplies	$RS = \frac{\text{quantity used in half the lead time}}{2} = \frac{AMC \times LT}{2}$	In examples above: a. $RS = \frac{500 \times 1}{2} = 250$ o-rings b. $RS = \frac{4 \times 6}{2} = 12$ bearings
Minimum Level [Min.] – reorder level, in other words, the stock level that indicates you need to place an order.	You must reorder when you reach this level to avoid running short of supplies. It will change as your usage rate and supplier/source changes, so it needs to be checked regularly.	$\text{Min.} = \text{reserve stock} + \text{stock used during lead time} = RS + (AMC \times LT)$	In examples above: a. Min. = 250 + (500 x 1) = 750 o-rings b. Min. = 12 + (4 x 6) = 36 bearings

Continued opposite

BOX 27: How to Calculate Reordering Times and Quantities (continued)

Supply Term Definition	Principle	Calculation	Examples
Order Quantity [OQ] – quantity of items that is ordered to be used in one supply period.	As the quantity ordered will be used up in the time between orders, it must be calculated to maintain stocks above the reserve stock level [RS] until the next delivery of supplies is received.	$\text{OQ} = \text{average monthly consumption} \times \text{time between orders}$ $= \text{AMC} \times \text{TBO}$	In examples above: a. $\text{OQ} = 500 \times 3 = 1,500$ o-rings b. $\text{OQ} = 4 \times 12 = 48$ bearings
Maximum Level [Max.] – maximum amount you will have at any time.	Usually you only have the maximum level just after receiving a delivery. It prevents you over-ordering. It will change as your usage rate changes, so it needs to be checked regularly.	$\text{Max.} = \text{reserve stock} + \text{order quantity}$ $= \text{RS} + \text{OQ}$	In examples above: a. $\text{Max.} = 250 + 1500 = 1,750$ o-rings b. $\text{Max.} = 12 + 48 = 60$ bearings
Example Summary:	a. You use 3,000 o-rings in six months, order them once a quarter, and they take one month to arrive. Thus, when 750 o-rings are left in stock, you place an order for 1,500 o-rings. Your safety reserve stock is 250 o-rings, and the maximum amount you ever have in stock is 1,750 o-rings. b. You use 48 bearings in a year, order them once a year, and they take six months to arrive. Thus, when 36 bearings are left in stock, you place an order for 48 bearings. Your safety reserve stock is 12 bearings, and the maximum amount you ever have in stock is 60 bearings.		

Figure 20: Sample Layouts for the Stock Control Ledger

Example 1:

Stock Control Ledger					
Item description:			Item code no:		
Unit/pack size:			Order quantity:		
Date	Quantity received	Quantity used	Balance	Quantity to order	Signature

Example 2:

Stock Control Ledger						
Item description:			Item code no:			
Unit/pack size:			Order quantity:			
Date	Previous count (physical)	Amount received	Amount used	Present count (physical)	Quantity to order	Signature

The HTM Manager and the workshop storesperson will routinely review the stock control ledger, and will submit the information on spare part and maintenance materials requirements and rates of use to:

- ◆ the Finance Officer in order to improve budget allocations (see *Guide 2* on planning and budgeting)
- ◆ the Purchasing and Supplies Officer, Specification Writing Group, and Tender Committee (see *Guide 3* on procurement and commissioning) in order to incorporate experience of the quality, performance, and cost of items into the next round of purchasing
- ◆ the Stores Controller in order to prompt the reordering process and timing of procurement.

Box 28 contains a summary of the issues covered in this Section.

BOX 28: Summary of Procedures in Section 6 on Spare Parts and Maintenance Materials

Needs	Health Service Provider	<ul style="list-style-type: none"> ◆ ensures sufficient spare parts and maintenance materials are available for the HTM Teams ◆ considers the use of a 'revolving fund' to help finance the need for spare parts and maintenance materials
	HTM Managers	<ul style="list-style-type: none"> ◆ decide the spare parts and maintenance materials required for different types of equipment
	Health Management Teams	<ul style="list-style-type: none"> ◆ buy good quality spare parts and maintenance materials
Storage System	Health Service Provider	<ul style="list-style-type: none"> ◆ decides whether equipment spare parts and maintenance materials will be stored in a separate section of the health service storage system, or a separate network of HTMS stores ◆ decides whether the HTMS will also take responsibility for storing equipment accessories and consumables ◆ provides the resources for a full stock control system ◆ decides whether to employ stores personnel throughout the system, or to train other staff to be storespersons ◆ provides training to ensure stores staff recognize equipment-related supplies ◆ develops an illustrated stores catalogue of equipment-related supplies
	HTM Managers (at all levels of the HTMS)	<ul style="list-style-type: none"> ◆ create suitable stores and sub-stores for equipment-related items ◆ follow rules for keeping a store ◆ provide advice/authority for the issuing of stocks, to ensure the correct parts are used for the correct application
	Stores Staff	<ul style="list-style-type: none"> ◆ implement a stores code numbering system for equipment-related items ◆ enter new equipment-related stocks onto stock/bin cards ◆ make equipment-related items 'stockable' items, whenever possible ◆ issue regular requirements to smaller sub-stores
Usage Rates and Reordering	Health Management Teams (or HTMWG)	<ul style="list-style-type: none"> ◆ undertake a one-off exercise to discover the usage rates and requirements of equipment-related supplies for which there is no current information available (see <i>Guide 2</i> on planning and budgeting)
	HTM Service	<ul style="list-style-type: none"> ◆ calculates annual requirements (see <i>Box 25</i>) ◆ calculates what spare parts and maintenance materials will be used by which HTM Teams at different levels of the Service (see <i>Box 26</i>) ◆ decides what quantities should be placed around the HTMS network (see <i>Box 26</i>) ◆ provides the stores staff with the results for the stock control system
	Stores Staff	<ul style="list-style-type: none"> ◆ calculate the reorder levels and order quantities (see <i>Box 27</i>) ◆ enter the data on the stock cards ◆ keep a stock control ledger ◆ use the prompts from the stock control system to reorder more stocks when they are required, so that stocks are always on the shelves

7. HOW TO MANAGE STAFF

Why is This Important?

Health service providers need to recruit sufficient staff, with the necessary skills, for the maintenance service, in order to try and guarantee the good physical condition of their equipment.

Effective mechanisms are required for maintenance staff to report on the status of equipment, HTM activities, and the HTM Team. But maintenance staff also deserve effective feedback regarding HTM issues so that they feel informed and encouraged to take responsibility.

Maintenance staff need a constructive staff appraisal system, to boost their morale and encourage career progression, in an attempt to retain skilled staff.

Planning the ongoing development of maintainers' skills is essential for responding to the rapid changes in equipment design, and for career progression. Thus a wide range of training strategies must be introduced.

Guide 1, on organizing an HTM system, includes a discussion on the overall management of staff in the HTM Service, such as the structure/organizational chart of the Service, establishment posts, and suitable job descriptions. *Section 2.2* of this Guide covers the framework requirements for maintenance staffing issues, which need to be resolved at the central level.

In contrast, this Section concentrates on the daily strategies for keeping HTM Teams happy in their work and improving their performance. This is achieved by:

- ◆ creating multi-disciplinary teams, so that staff are not over-stretched (*Section 7.1*)
- ◆ using suitable reporting and feedback methods, so that staff know what is going on (*Section 7.2*)
- ◆ evaluating staff performance, so career development goals can be set (*Section 7.3*)
- ◆ developing their skills further (*Section 7.4*).

7.1 CREATING MULTI-DISCIPLINARY TEAMS

The first (lowest or simplest) level of the HTM Service should be HTM Teams based at small health facility level where there are no workshops. These HTM Teams are made up of a couple of suitable (and interested) staff from any discipline (such as a nurse, a clinical officer, an administrator, a storesperson).

From there on up the HTM referral network, the technical skills increase at larger health facilities and centres where workshops exist. These HTM Teams comprise a combination of different types of technical personnel (such as craftsperson, artisan, technician, technologist, engineer, and engineering managers). The composition of each team depends on the type of technical personnel available in your country, and on the frequency and difficulty of the maintenance tasks they undertake (see *Guide 1* and *Annex 3*).

Depending on the number of agencies who have been given responsibility for maintaining different equipment types (*Section 2.2*), your organization may be maintaining a wide range of equipment (see *Box 1*). Thus, you may require a variety of types of staff who can cover a broad spectrum of technical skills, such as:

medical electronics	electrical installations
electro-medical systems	mechanics
plumbing	refrigeration and air-conditioning
carpentry	bricklaying
automotive work	technical management

Thus, it is preferable to have multi-disciplinary HTM Teams in the HTM Service which work together for the good of each health facility as a whole (*Section 2.2*).

In order not to over-stretch your team with the workload, it is important to employ **qualified** maintenance staff where possible. Of course, it can be useful to employ unqualified staff if you have suitable arrangements for training them on the job and in service, so they can gain recognized skills.

To be able to find maintenance staff with the necessary skills, there need to be sources of basic training in your country or geographical region. *Box 29* shows the sorts of basic training required. Your health service provider and the HTM Service can negotiate with training institutions to modify some courses to be more useful to the field of healthcare technology management (*Section 7.4*). The availability of these courses and your ability to access them will depend on the country you live in.

BOX 29: Basic Training Requirements (see Annex 2)

- ◆ on-the-job training
- ◆ various grades of trade tests for artisans
- ◆ various grades of certificates and diplomas for technicians and technologists
- ◆ degrees for engineers
- ◆ healthcare technology specific training courses
- ◆ management training courses

It may be difficult to find suitable technical staff and to provide them with the correct training in physiology and anatomy so that they can deal with medical equipment. You may need to develop innovative strategies to obtain sufficient maintenance staff. For example, some developing countries have employed doctors in their HTM Service, and trained them in the necessary electronics and engineering subjects instead.



- Tip** • Try to encourage more women to become maintainers. There is a vast pool of women in the health service already working with equipment who may be encouraged to take a greater role in keeping the equipment stock functioning.

There are no rules which dictate the number of staff you must employ, but *Guide 1* provides some guidance for the HTM Service as a whole. Each HTM Team needs a minimum staffing level to be able to carry out the required maintenance – and other HTM – work. The responsibility for managing the equipment should always remain with the health service provider. Therefore, as an absolute minimum, you need to employ sufficient staff to maintain full control of the situation. In other words:

- ◆ To know what's going on and understand the condition of the equipment.
- ◆ To monitor the work of contractors and staff hired on an occasional basis.

However, further, more qualified staff are considered to be essential at workshops, to ensure all equipment is functioning and continuously reliable.

Depending on your level of autonomy, you may hire your own HTM staff or the hiring may be undertaken centrally. Your health service provider needs establishment posts to hire HTM staff against. These ensure that staff are properly placed within the organizational chart for the health service as a whole. This chart must provide an effective reporting structure for daily operational matters, allowing HTM staff to report to the Health Management Team at their facility or decentralized authority level (such as a district health authority).

HTM Managers must be at suitable reporting levels that reflect the importance of being responsible for managing the equipment which enables health services to be provided (*Section 2.2*). In addition, the HTM Service organizational chart (*Section 2.1*) should provide HTM staff with suitable professional support and routes for career progression.

The HTM Service is responsible for looking after the interests of maintenance staff. *Guide 1* describes the reporting structures for maintenance staff in both the health service and the HTM Service, and how they are interlinked.

Job descriptions are crucial tools for managers to make the best use of the staff available, to plan for further training, and to recruit suitable people. They are equally important for each worker as they are a guideline for the work expected of them, the skills required, and possible ways to achieve promotion. However, it is important not to limit any individual to work only at a specific level as this could seriously hamper the running of the HTM Service. An engineer must sometimes be prepared to carry out work described for technicians, and even, occasionally, the work of a cleaner. Sample job descriptions for the HTMS are provided in *Guide 1*.

Poor terms and conditions of employment could lead to the loss of valuable and qualified staff. This would mean the loss of valuable knowledge of the health service's equipment and reticulation systems, which cannot be replaced even if new staff are immediately appointed.

Employment conditions such as salary, number of days' holiday, illness and overtime entitlements are important. But working conditions for maintenance staff are also significant, such as supportive supervision, suitable tools, other resources to undertake the work required, as well as opportunities to attend meetings and conferences to develop their skills. Your organization's skill at staff management and career development will depend on its Human Resources policies and strategies (*Section 2.2*).

7.2 REPORTING AND FEEDBACK

There are various forms of reporting and feedback, both formal and informal.

Formal methods involve such things as written reports to senior management, and the system for appraising staff as set up by the Human Resources Department (*Section 7.3*).

Informal methods involve verbal reports, the use of meetings to share information, and support and supervision activities.

It is common for the informal methods to get forgotten, as long as there is peace within the team. However, informal information paths are often a source of frustration and should not be underestimated. Methods are required to ensure that information goes both up and down the reporting structure (from staff to managers and back again), as well as sideways (between departments and colleagues).

Remember that maintenance staff have to report to both the HTM Service and their Health Management Team. Not only do staff have a responsibility to report on equipment-related activities, but also they deserve feedback on such issues. In this way staff:

- ◆ are informed
- ◆ can obtain support
- ◆ feel involved and empowered
- ◆ can be encouraged to take responsibility.

Staff need feedback on their activities, and answers to their queries, so that they can benefit from experience and feel a part of the system as a whole. Part of the management of equipment-related activities is the identification of problems and needs. All equipment-related activities should be monitored (*Section 8*), and the results of such monitoring are useful for providing feedback to staff and senior management.

Various methods of formal and informal reporting and feedback are described elsewhere in this Guide:

- ◆ Support and supervision of HTM Teams by outreach (*Section 3.6*).
- ◆ The responsibility of users to promptly report equipment faults to the HTM Team (*Section 4.2*).
- ◆ Appraisal of staff and setting personal goals (*Section 7.3*).
- ◆ Monitoring equipment and maintenance statistics to provide data for planning purposes (*Section 8*).

This Section covers:

- ◆ feedback from the HTM Team to the user departments regarding plans and progress with maintenance work
- ◆ planning with, and feedback to, HTM Teams by their managers
- ◆ reporting by HTM Managers to senior management.

Feedback from the HTM Teams to Users

Once equipment users have requested maintenance, it is very important to keep them informed of progress. Common problems are:

- ◆ Users left in the dark wondering what is happening – this makes it very difficult for them to plan their work.
- ◆ Users not told that outsiders (external staff) will be arriving to undertake repairs in their department.
- ◆ Users not told when they can expect their equipment to be functioning again.

It is much easier for user departments to accept problems and understand the HTM Team's difficulties, if reasons are given and delays explained. *Figure 21* provides some strategies.

The heads of equipment user departments should also review their User Department Maintenance File (*Section 4.2*) regularly (at least every month). Doing so gives them valuable information on the progress made with maintenance requests, and enables them to monitor this progress.

Figure 21: Strategies for HTM Teams to Provide Feedback to Users

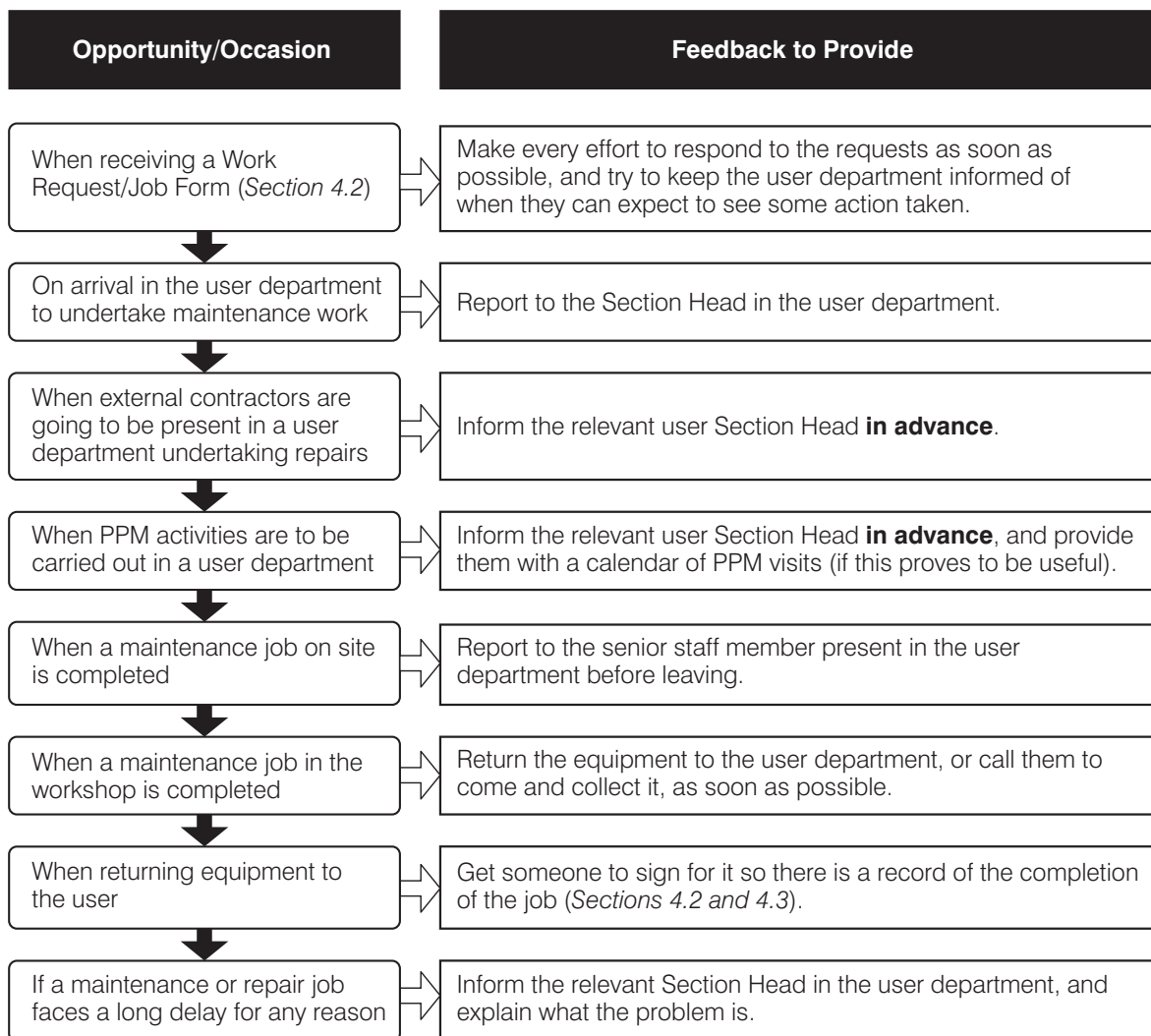

Feedback from HTM Managers to their Teams

Maintenance staff need to know what is going on regarding their work and responsibilities, but also regarding the health service they work in and the maintenance service and profession they belong to. It is common for maintenance staff to feel that only managers attend meetings, that their viewpoint is never heard, and that they never discover what has been agreed at the meetings.

To avoid this situation, HTM Managers need to hold regular team meetings. It is important that **all** members of staff are involved, and obtain feedback on their activities and answers to their queries.

In general, there are two types of meeting:

- ◆ Weekly work planning meetings.
- ◆ Other regular (but less frequent) team meetings.

Weekly work planning meetings allow the progress of work to be monitored regularly, and help identify problems and needs within the team. The weekly work planning should be based on the information kept in the maintenance record system (*Section 4*). These meetings should be used to guarantee that all staff within the HTM Team are involved in:

- ◆ the management of maintenance
- ◆ planning the work the department will carry out
- ◆ costing and prioritizing work for submission to the Health Management Team for expenditure against the maintenance budget.

The HTM Manager should use the Jobs Pending Files and the Stock Control Ledger for the meeting (*Sections 4.2 and 6.3*), to:

- ◆ discuss new pending jobs, ongoing jobs, and jobs awaiting inputs
- ◆ plan and prioritize the work required
- ◆ investigate spare parts and other requirements and costs
- ◆ make a work plan of priority activities for the coming week, for which resources are available
- ◆ compile a priority list of requests for resources that are absent.

In addition, the HTM Manager holds **regular meetings** to discuss the plans for the team and feedback about the team. These meetings should be used to guarantee that all staff within the HTM Team:

- ◆ are involved in, and kept abreast of, ongoing maintenance issues
- ◆ can have their views recorded so that the HTM Manager will represent them adequately at Health Management Team meetings
- ◆ learn of the decisions made in Health Management Team meetings, which the HTM Manager has attended
- ◆ are aware of any feedback about their work
- ◆ are aware of the plans and goals for the team, and their progress towards them (*Section 8*).

Feedback from HTM Managers to Health Management Teams

Depending on where the HTM Team is based, HTM Managers may need to make regular (perhaps weekly) verbal reports to the Health Management Team, in order to report equipment problems and progress. They also need to provide written HTM status reports to various people, possibly every quarter.

These reports will be required by the HTM Manager's immediate boss in the HTMS, and their boss in the health service (in other words, the relevant Health Management Team at facility, district, regional or central level). *Box 30* shows the sorts of information which should be covered by the written status reports.

The HTM Manager uses all aspects of the maintenance record system (*Section 4*) to keep themselves aware of what is happening in the HTM Team on a daily basis, and uses this information to make verbal reports to their immediate bosses in the health facility/authority and the HTM Service as required. To compile the written status reports, the HTM Manager needs to:

- ◆ regularly monitor the data in the maintenance record system
- ◆ use the statistics gathered about the HTM Team (*Section 8.2*)
- ◆ refer to any financial data that he or she is required to keep (see *Guides 2 and 6*).

BOX 30: Typical Contents for HTM Status Reports

Subject areas	Examples
Progress	<ul style="list-style-type: none"> ◆ The number of jobs successfully completed (this can be divided into maintenance jobs and other HTM activities, such as installation, training, and decommissioning). ◆ The achievements made in correcting outstanding problems. ◆ Any new initiatives undertaken.
Equipment problems	<ul style="list-style-type: none"> ◆ Outstanding maintenance problems. ◆ Types of equipment which are breaking down most frequently. ◆ The most common causes of breakdowns. ◆ Other outstanding problems, such as the need for training, commissioning, and disposal.
HTM Team/workshop problems	<ul style="list-style-type: none"> ◆ The most common causes for delays in completing tasks. ◆ The quantity of materials and spare parts used, the additional spares and materials required to complete outstanding work, and the quantities required in future. ◆ The sorts of skills absent within the HTM Team. ◆ The type of cooperation received from equipment user departments.
Performance	<ul style="list-style-type: none"> ◆ Periodic feedback on progress against performance indicators, which are set annually (<i>Section 8</i>).
Finances	<ul style="list-style-type: none"> ◆ How the previous month's maintenance allocation was spent. ◆ The costed requirements for expenditure against the next month's maintenance budget. ◆ Any additional data on financial issues for HTM (see <i>Guides 2 and 6</i>).

7.3 EVALUATION OF STAFF AND ONGOING APPRAISALS

A formal staff appraisal process is required in order to monitor the work performance of individuals, and to identify areas for goal-setting for both the individual and their manager. A good appraisal system also has arrangements for workers to comment on the performance of their manager. The purpose of the interaction is to:

- ◆ guide the individual in their job
- ◆ evaluate their performance
- ◆ take corrective action to improve job performance
- ◆ agree required training, development, and other strategies by the employer, which would assist the employee to become more effective in their job.

The aim of the process is to have open one-to-one meetings between the individual member of staff and their manager or a member of the Human Resources Department. Together, they need to review the individual's performance, set personal goals, identify skill-development requirements, and suggest solutions for the constraints found. In some organizations, such processes are viewed negatively by staff. A system needs to be developed and implemented which doesn't make staff feel that:

- ◆ their boss is in control of the proceedings
- ◆ personal grudges or influences are at play
- ◆ the process is only disciplinary
- ◆ they should be wary of having their performance monitored
- ◆ they are being continually watched.

A good staff appraisal system allows both parties to enter into a discussion that is constructive, and not simply complaining or disciplinary. The process should be seen as a positive two-way negotiation of methods for improving performance, in other words what the individual can do, but also what the manager can do to make the working situation better. The amount of work that has already been done in this direction will depend on the policies and procedures of your local Human Resources Department.

The good and bad performance of staff in relation to equipment should be recorded and fed back into the staff appraisal process. Staff appraisal is an important part of constructive career progression.

7.3 Evaluation of staff and ongoing appraisals

We suggest that, to prepare for this process, each member of the HTM Team keeps their own Personal Record Book (*Section 4.3*). How much each person records will vary, but when a maintenance task is completed he or she should record the following types of things:

- ◆ their strengths
 - special solutions found for problems
 - hints and tips
 - what made things turn out better
- ◆ their weaknesses
 - special problems encountered
 - difficult maintenance tasks which they could not solve
 - methods that failed
- ◆ possible solutions
 - training wishes
 - additional resources required
 - altered working practices
- ◆ response to inputs
 - training or help received, and what they thought of it
 - opportunities, to meet colleagues or discuss issues, and what they thought of them.

The staff appraisal meeting usually takes place once a year. *Box 31* provides some strategies for holding these meetings, and progressing the careers of each staff member.

BOX 31: Strategies for Staff Appraisal Meetings

Preparation before the meetings	<ul style="list-style-type: none"> ◆ Throughout the year, each HTM Team member uses their Personal Record Book to try to identify their strengths and their weaknesses, and any solutions that would have made their work turn out better. ◆ Each HTM Team member uses the issues in their Personal Record Book to prepare for the frank discussions required as part of staff appraisal, and takes their book along to their appraisal meeting.
Procedure	<ul style="list-style-type: none"> ◆ An HTM Manager or a member of the Human Resources Department meets with each staff member in turn, and makes use of any guidance and forms available in the local Human Resources policy and procedures.
Process	<ul style="list-style-type: none"> ◆ The manager and staff member have a frank discussion in order to: <ul style="list-style-type: none"> - identify the personal strengths and weaknesses of the individual - identify ways in which the strengths can be recognized and utilized (for example, be given greater responsibility, be allowed to train colleagues, be able to apply for promotion) - identify solutions for the weaknesses (for example, on-the-job training, attending an external training course, obtaining a different tool, gaining access to transport, making better use of time, getting extra help to share the workload, providing more support, providing better supervision) - take note of any reported good or bad performance by the individual in relation to equipment, and take these into account when agreeing actions - reach agreements which state what each party (both the individual and the manager) will do over a set period of time (for example, the manager agrees to provide the individual with on-the-job training, the individual agrees to arrive for work on time) - review the progress made since the last staff appraisal meeting, with the goals set for the individual and the manager, and identify any constraints to progress - set further personal goals to be achieved over specified periods of time.



Experience in Botswana

Kgalagadi Breweries introduced managed maintenance by hiring maintenance management consultants to work with their maintenance department to develop a new system. The changes made were:

a. Work management:

- ◆ *Introduction of job cards (with four copies for different purposes and files), equipment service records, PPM schedules, stock control cards, and user department monitoring.*
- ◆ *Development of work plans which had to be adhered to.*
- ◆ *Introduction of a visual display board system so that the Maintenance Manager could keep track of the progress of all jobs, and where staff were occupied.*

b. Personnel management:

- ◆ *Organization of maintenance staff into mixed ability teams, so they could support each other.*
- ◆ *Involvement of each member of staff and team in developing their own work goals.*
- ◆ *Public display of progress against goals so that everyone was open about team and personal achievements.*
- ◆ *Support within teams and an atmosphere which enabled members to congratulate other individuals, or chide and encourage them.*
- ◆ *Help for individuals to identify their problems and the constraints to better productivity.*
- ◆ *Development of personal improvement strategies.*
- ◆ *Feedback on progress, improvement, and planned responses.*
- ◆ *Offers to attend training programmes.*
- ◆ *Increases in salaries and incentives for improved performance.*
- ◆ *Ultimately, staff could be fired if they continually performed poorly or without commitment.*

These initiatives worked well. Staff motivation, performance, and productivity improved. The initiatives instilled an attitude in the staff of personal pride in their work, through the use of team building and new working relationships.



- Tip** • Recognition for outstanding work is a great morale booster. Good maintainers can save enormous amounts of time and money, and should be recognized and rewarded for their efforts in many ways – occasional cash bonuses or gifts, mentions in newsletters, a photograph on a notice board – anything that works.

7.4 SKILLS DEVELOPMENT

Since so many new makes and models of equipment are coming out almost every year, maintenance staff need to continually update their skills. Equipment training for maintainers needs to cover:

- ◆ planned preventive maintenance (PPM) for users
- ◆ PPM and repair for maintainers
- ◆ maintenance management
- ◆ management of stocks and stores
- ◆ procurement procedures and tender adjudication (see *Guide 3*)
- ◆ financial planning and accounting (see *Guides 2 and 6*)
- ◆ protocols concerning how to work in the health facility environment (*Section 3.5*).

However, maintainers also need knowledge of other skills common to equipment users (see *Guide 4*) as follows:

- ◆ Good practice when handling equipment – basic do's and don'ts.
- ◆ How to operate equipment.
- ◆ The correct application of equipment.
- ◆ Care and cleaning.
- ◆ Safety procedures.

Remember that training shouldn't be an activity that only happens once. Training is required at various times throughout a member of staff's career:

- ◆ Induction training – when staff are newly placed in post, move to a new department or facility, or to a new location with different responsibilities.
- ◆ Training at the commissioning of equipment – when new equipment first arrives.
- ◆ Refresher training – to update and renew skills throughout the working life of staff.

The provision of such training must be addressed seriously by the health service provider. There are a number of options available for developing skills in service, and each health service provider has to pursue a combination of strategies for sourcing the training required. Whatever options prove to be the most feasible, a skills development programme is vital. As explained in *Section 2.2*, the training needs of staff at every level should be addressed by the overall Equipment Training Plan, which is an ongoing rolling programme of in-service training.

We suggest that the HTM Working Group, or possibly a smaller training sub-group (*Section 1.2*), is responsible for establishing training requirements. This Section looks at some strategies which can be introduced at the facility or district level to implement the Equipment Training Plan (developed in *Guide 2* on planning and budgeting).

Box 32 provides a variety of strategies to help you consider the sources of training and professional support available.

When you begin to monitor maintenance work, you will notice a number of prompts that training is required. These training requirements should be passed on to your Health Management Team and the HTM Service (*Section 8.2*). *Figure 22* shows the likely prompts.

Figure 22: Example of Prompts Showing That Training is Required

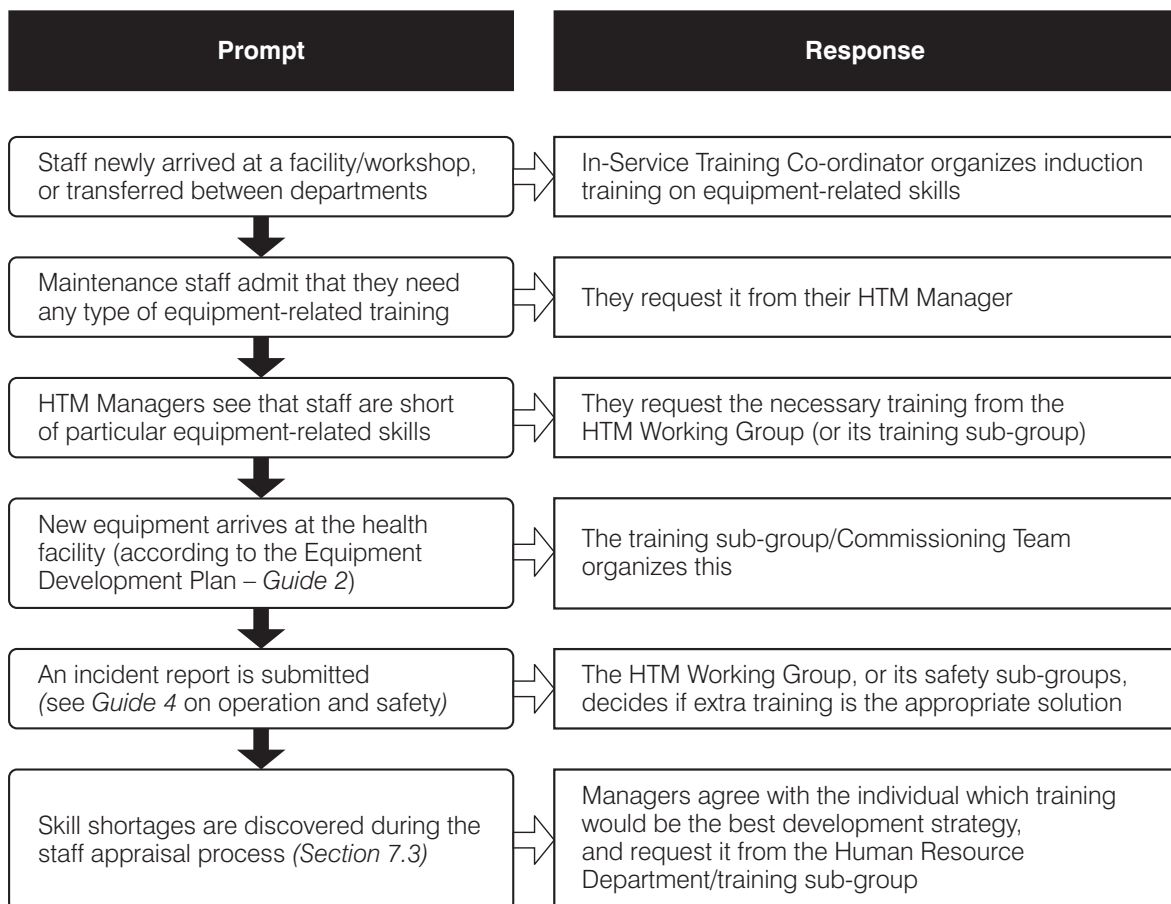

BOX 32: Strategies for Developing Equipment Skills

Strategy	Advantages/Disadvantages
Send staff to factories that manufacture equipment	This can be good training but may be expensive as it often entails going abroad and paying in foreign currency. However, the equipment manufacturer may have a local representative that has the skills to provide the necessary training. Although this is a more affordable option, the danger is that the company will offer a course which is either too simple (not much more than a factory tour), or alternatively is very theoretical. Good communication is required to ensure that this equipment-specific training is effective and appropriate.
Invite engineers from manufacturers to visit your facility to conduct training on their equipment.	This option may not be the most affordable, and therefore may not be ideal if you are facing financial constraints. If the company's local representative has sufficient skills to undertake the training, this may be more affordable.
Send staff to other locations which have already developed the skills required.	Other facilities, workshops, or teams may already have developed skills that you need. Here your staff can either attend specific training courses, or have a period of secondment in order to obtain skills through on-the-job training, work experience, or work exchange visits.
Link the provision of training to the procurement process.	When equipment is purchased from a company, you can ask them to provide training at the time of commissioning (see <i>Guide 3</i>). Who covers the cost of the training and where it will take place is negotiated in the procurement contract, and may be dependent on the type and total cost of the equipment.
Run in-house (on-the-job) training sessions	You can make use of local, national, or regional experts who are maintenance and/or clinical staff. It may be necessary to send some staff for training abroad so that they can become the local trainers/experts.
Make use of regular clinical/professional meetings	These can be used as a forum to introduce staff to particular equipment concerns. They can be run at facility, district, central, or international levels.
Make use of academic courses at various levels	These are useful for gaining additional specialist skills. They will be available nationally, regionally, and overseas (see <i>Annex 2</i> and <i>Box 29</i>).
Approach local colleges to develop, run, and accredit new modules specifically designed for your equipment needs	<ul style="list-style-type: none"> - The Trade Testing Authority can develop trade tests suited to the range of skills used by artisans/craftsmen who maintain healthcare technology, so they can progress in their careers. - The Polytechnic can combine a mixture of existing engineering modules to create a certificate or diploma course suited to the range of skills used by technicians who maintain healthcare technology, so you can hire and train more suitably qualified staff.
Provide opportunities for practical on-the-job experience	Practical experience, with or without supervision, provides excellent training as long as it is targeted at the right skill level. When a piece of equipment is not in use, staff should be encouraged to familiarize themselves with the equipment, and learn its principles and the technical solutions for specific problems.

Continued opposite

BOX 32: Strategies for Developing Equipment Skills (continued)

Strategy	Advantages/Disadvantages
Provide opportunities for studying and teaching	Books, manuals, and articles from journals will give answers to many questions on principles of maintenance and repair for different types of equipment (see <i>Annex 2</i>). If staff are given opportunities to study, with a little pressure and an expectation that they will lecture to colleagues afterwards, the benefits for individuals can be great.
Let maintenance staff attend peer group meetings	This allows staff to share experiences regarding equipment, learn from their colleagues, and develop a professional approach to work. The meetings will be available nationally and internationally.
Provide various training materials for staff to refer to (see <i>Box 7</i> and <i>Figure 23</i>).	The materials, together with demonstrations, help staff to learn and provide them with something to regularly refer to when uncertain. The materials can be hand-outs, posters, OHP acetates, laminated cards, etc.
Provide work placements for student maintainers in your workshop	This will raise your profile and give you contacts with training institutions. The students may also return to you for employment when they graduate, and you will already have a good idea of their abilities.

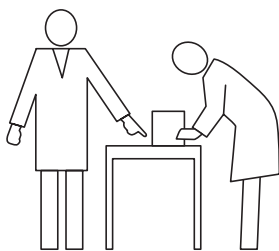

on-the-job

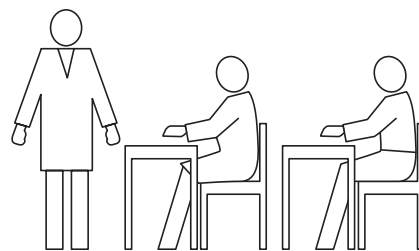

seminars

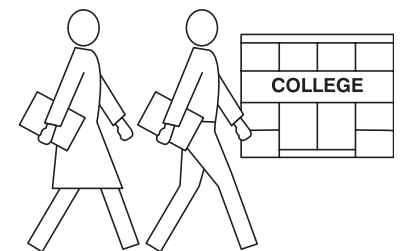

going to college

A variety of resources can help you when you decide to undertake training yourself. These will vary depending on the training source, and on which of the available skill-development options (described in *Box 32*) you use. *Box 33* details some of the resources you may require.

BOX 33: Resources Required When Running Training Courses Yourself

Information	about the training required (background and needs assessment) and the training sources available.
Training materials	appropriate to the piece of equipment to be studied.
Space	suitable for carrying out the training in.
Equipment	to be practised on during the training courses.
Test and calibration instruments	in order to verify technical conditions and safety during training.
Spare parts and materials	appropriate for maintenance training.
Supplies	for operation (and user training), such as consumables, medical supplies, and cleaning materials.
Manuals	to refer to, such as the manufacturer's operator and service manuals.
Test method and certificate	a formal way of testing trainees and issuing them with a certificate at the end of the training course, as a quality control and motivating factor (depending on the extent of the training).
Recognition	a formal way of ensuring that the additional skills attained by staff are reflected in their promotion chances and job grades by the Human Resources Department.
Additional expenses	possible room hire, overnight accommodation, travel and subsistence, trainers' fees, visual aids, teaching equipment, etc.
Records	a system for keeping a record of the specific training that a staff member has received.

Developing Training Materials

We suggest you develop simple guidelines for each type of training required for every type of equipment, based on good principles and procedures. This Series includes the following examples:

- ◆ *Guide 2* covers equipment planning and budgeting, including taking inventories and writing specifications.
- ◆ *Guide 3* covers procurement, adjudication of tenders and quotes, installation, commissioning, and acceptance testing.
- ◆ *Guide 4* covers good practice when handling equipment (basic do's and don'ts), how to operate equipment, the correct application of equipment, care and cleaning, safety procedures, decommissioning, planned preventive maintenance (PPM) for users, and management of accessories and consumables.
- ◆ *Guide 6* covers financial management for HTM Teams.
- ◆ Finally, this Guide, *Guide 5* covers PPM and repair for maintainers, work planning, management of the work place, tools, spare parts and maintenance materials, and stock control.

The specific guidelines for different equipment types should be modelled on the advice in:

- ◆ the equipment manufacturers' operator and service manuals
- ◆ the manufacturers' PPM schedules
- ◆ written resources produced by other organizations (see *Annex 2*).

Training can also incorporate the experience of existing staff. *Figure 23* shows a number of strategies to follow when developing training materials.

Figure 23: Strategies for Developing Training Materials

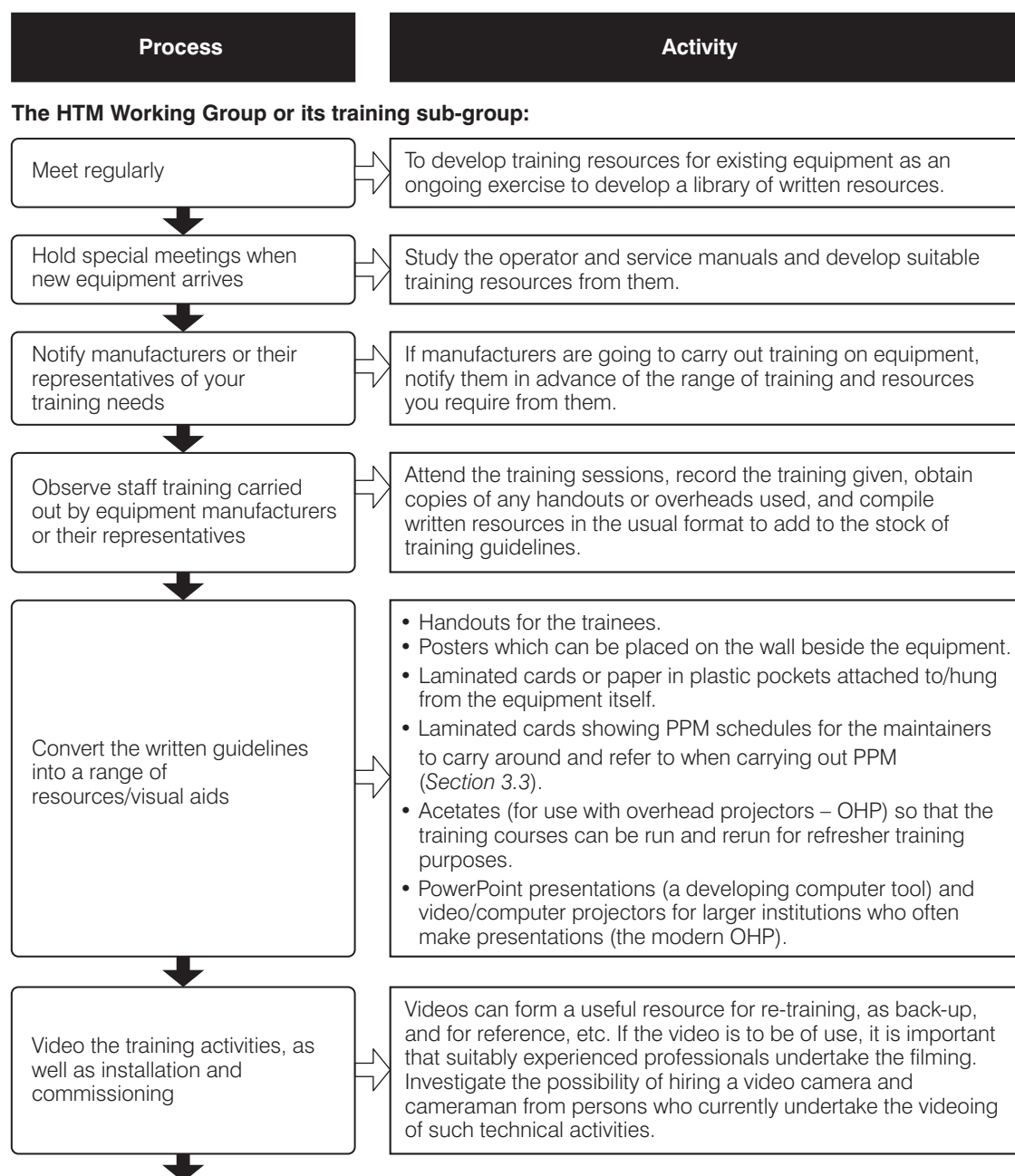

Continued overleaf

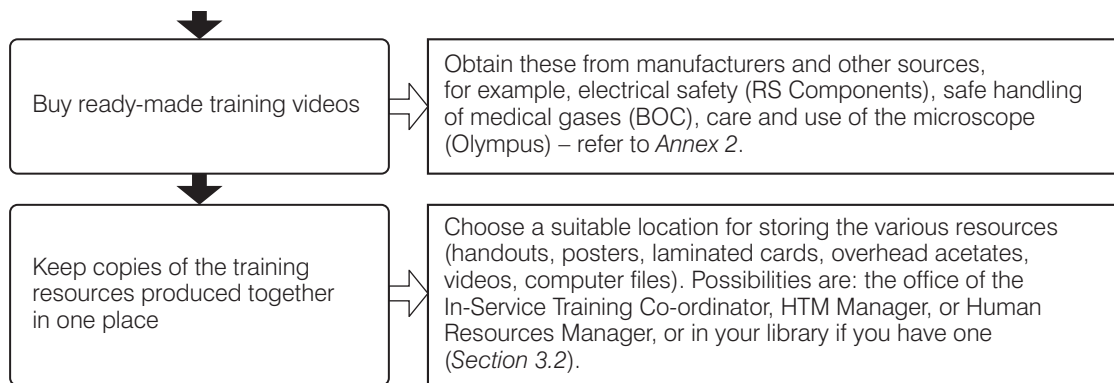
Figure 23: Strategies for Developing Training Materials (continued)

Training Trainers

The trainers who run the equipment training sessions are usually one or more of the following:

- ◆ Staff from the equipment manufacturer.
- ◆ Staff from the manufacturer’s representative.
- ◆ Maintenance or clinical staff from other teams, workshops, health facilities, and health service providers who are knowledgeable about the equipment.
- ◆ Senior maintenance or clinical staff within your team, workshop, or health facility who were previously trained on the equipment or who have the necessary skills.
- ◆ Partners in technical cooperation projects, or staff from non-governmental organizations and charities.

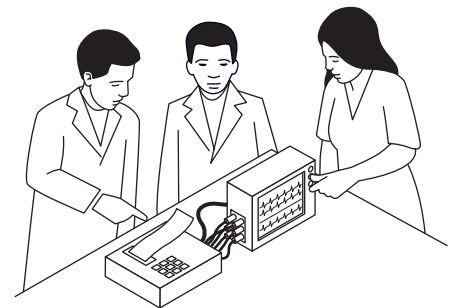

If you don’t currently have enough trainers, you can nominate staff who can be trained to become trainers. When maintainers are being trained at the time of commissioning new equipment, it may be useful to select staff from among the trainees who you would like to become trainers. These individuals can then go on to train staff who could not attend the initial training sessions: for example, a technician at district level could be trained to teach artisans around the district.

The trainers will need to be taught sufficient skills to train their colleagues. They should be capable of running both formal and informal training sessions in order to pass on their skills in the operation, safety, care, and maintenance of equipment. They will require training on the equipment concerned and can receive this either from the manufacturer, from other facilities where the equipment is in use, or from colleagues with the necessary experience.

Box 34 contains a summary of the issues covered in this Section.

BOX 34: Summary of Procedures in Section 7 on Staff Management

Creating Teams	Health Service Provider	<ul style="list-style-type: none"> ◆ ensures the recruitment of sufficient numbers of suitably skilled technical staff for the HTM Service, in multi-disciplinary teams ◆ enables general health staff to be members of first-level HTM Teams at small health facilities ◆ provides a suitable organizational chart, posts, terms and conditions, and reporting structure for the HTM Service
	Health Management Teams and HTM Service	<ul style="list-style-type: none"> ◆ implement suitable Human Resource policies and procedures to hire HTM staff and to try and retain them in post ◆ utilize job descriptions to identify and make use of staff wisely
Reporting and Feedback	Equipment Users and their Managers	<ul style="list-style-type: none"> ◆ report any faults to their HTM Team immediately they occur (<i>Section 4.2</i>) ◆ use the User Department Maintenance File to review progress on maintenance work
	HTM Teams	<ul style="list-style-type: none"> ◆ keep user departments informed of progress with maintenance (<i>see Figure 21</i>) ◆ participate in regular team meetings
	HTM Managers	<ul style="list-style-type: none"> ◆ hold weekly work planning meetings with their team ◆ regularly hold team meetings to discuss the direction of the team and its place in the health service, and provide feedback ◆ make verbal and written reports to the Health Management Team and the HTMS
Staff Appraisal	Health Service Provider	<ul style="list-style-type: none"> ◆ ensures there are good Human Resources staff appraisal strategies
	Maintainers	<ul style="list-style-type: none"> ◆ keep a Personal Record Book ◆ bring the Personal Record Book to the staff appraisal meeting, and participate in a constructive process
	HTM Managers (at all levels of the HTMS)	<ul style="list-style-type: none"> ◆ hold staff appraisal meetings, and participate in a constructive process ◆ implement solutions possible with existing resources, to correct any problems identified during the appraisal process

Continued overleaf

BOX 34: Summary of Procedures in Section 7 on Staff Management (continued)

Skills Development	Health Service Provider	<ul style="list-style-type: none"> ◆ develops and funds an Equipment Training Plan (see <i>Guide 2</i> on planning and budgeting) ◆ provides inputs for the in-service training programme ◆ coordinates training scholarships (<i>Section 2.2</i>) ◆ considers 'bonding' issues for staff sent for training (<i>Section 2.2</i>)
	HTM Service	<ul style="list-style-type: none"> ◆ investigates and uses the broad range of training sources available (see <i>Box 32</i>)
	HTM Working Groups (or Training Sub-Groups)	<ul style="list-style-type: none"> ◆ develop training materials (see <i>Figure 23</i>) ◆ identify and train suitable staff to be trainers ◆ receive and act on any prompts which indicate that staff need training (see <i>Figure 22</i>) ◆ provide the necessary resources when running training courses themselves (see <i>Box 33</i>)

8. HOW TO UNDERTAKE ACTION PLANNING AND MONITORING OF PROGRESS

Why is This Important?

Managing the activities described in this Guide will involve a cycle of actions. You need to monitor your performance, and set yourself goals so that you can improve. Then you monitor your progress, revise your goals, and review your progress again – thus undertaking a continuous cycle of planning and review. Such evaluation helps you to ensure the quality of your work. This is one element of quality management – an important goal for managers.

The planning and review activities are interlinked in a cycle as shown in *Figure 24*, but it is necessary to start the discussion at some point in the cycle. This Section discusses:

- ◆ the planning process (setting goals) in *Section 8.1*
- ◆ the review process (monitoring progress) in *Section 8.2*.

Figure 24: The Planning and Review Cycle

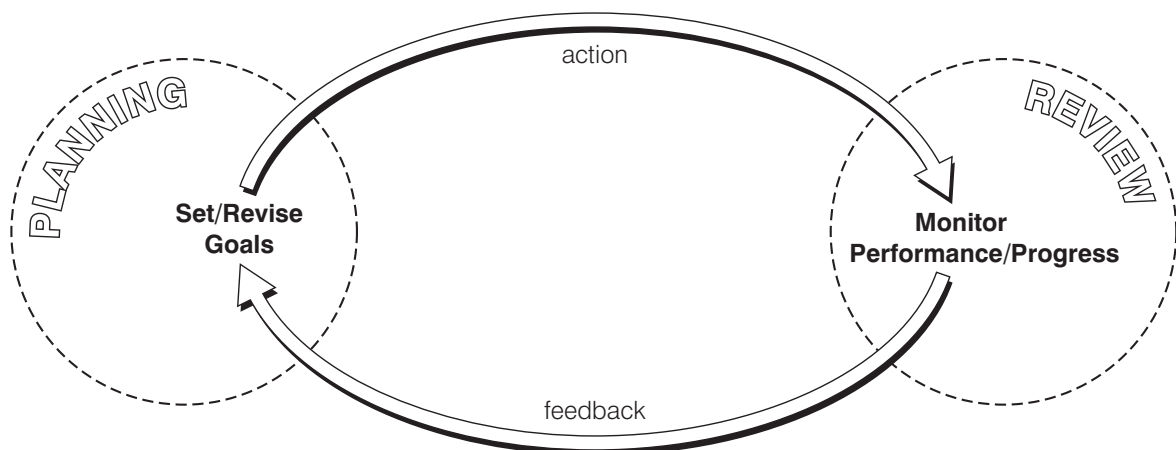

All staff involved in equipment maintenance should be involved in planning and reviewing their progress with this work. Thus, this Section is relevant for all different types of staff in:

- ◆ HTM Teams
- ◆ HTM Working Groups
- ◆ their various sub-groups
- ◆ staff from equipment user departments who undertake user PPM.

The main outcome of the planning and review process is that you are able to evaluate your performance. This is important for ensuring the quality of your work (quality assurance), which is an essential component of quality management.

Aims of Quality Management

- ◆ client satisfaction
- ◆ cost efficiency
- ◆ compliance to laws

We recommend that quality management is introduced into the health management systems of all the decentralized levels of the health service. It can help to improve staff attitudes, and this, in turn, can help staff handle the challenges connected with the many reforms and new management tasks they face (such as those described in this Guide). Important elements of quality management are:

- ◆ a management team approach
- ◆ supervision and evaluation
- ◆ participative leadership
- ◆ methods for encouraging staff
- ◆ individual responsibility and initiative
- ◆ control measures such as performance measurements and impact analysis
- ◆ community participation.

8.1 SETTING GOALS (ANNUALLY) FOR EQUIPMENT MAINTENANCE

Purpose

It is necessary for each HTM Team to have goals and plans which set out their priority activities. The goals and plans must be clearly defined so that they guide the work of:

- ◆ the HTM Team
- ◆ the health facility or decentralized health authority level the team is based at
- ◆ the HTM Service
- ◆ the health service as a whole.

The goals and plans will also enable staff and managers to monitor their own performance and progress with regard to the maintenance and repair of equipment (as well as their wider range of HTM activities).

Every team or department can benefit from an Annual Action Plan which contains clear, specific goals relating to its key activities. An action planning process should take place once a year, as standard practice. This is an opportunity for the members of the team to agree the range of activities (initiatives and changes) they want to implement, because they believe the activities will improve:

- ◆ their working environment
- ◆ their performance
- ◆ the service they provide.

There are boundaries and limitations to this planning process. The need for major investments in equipment should be discussed outside the annual action planning process, through activities such as the Equipment Development Planning exercise (see *Guide 2* on planning and budgeting). Similarly, ongoing shortages of staff or money are usually excluded from the annual action planning process, and should be addressed instead by higher authorities who can influence such issues.

Instead, we suggest that annual action planning should focus on improvements and changes that staff can undertake themselves, and that can be achieved with existing staff, equipment, facilities and other resources. Staff involved in maintenance should devise a wide range of initiatives and goals for all aspects of their work, such as:

- ◆ obtaining information about new products
- ◆ improving operator skills in using equipment
- ◆ implementing safety testing procedures
- ◆ improving stock control of spare parts and maintenance materials
- ◆ improving PPM
- ◆ quicker maintenance response
- ◆ more successful repair outcomes.

The planning process, and the plans themselves, should be clear and straightforward. This assists participation and produces goals that can be understood and used by all staff. Staff who are involved in setting goals and preparing plans are more likely to be committed to carrying them out. Thus, the planning process should incorporate representatives of all different types of staff, from all relevant disciplines.

We suggest that you hold an action planning seminar once a year. Such seminars can be held in various ways:

- ◆ Either across a ‘horizontal’ level of the health service, in other words, planning for the health service as a whole with participation from all disciplines (including the HTM Team), undertaken by your health facility or by your district health authority.
- ◆ Or across a ‘vertical’ professional programme within the health service (such as the maintenance service, or laboratory service). In this case, representatives would meet from all the HTM Teams, for example, in your district, or region, or throughout the health service as a whole.

The main purpose is to establish an annual planning cycle which:

- ◆ reviews past performance, problems, and needs
- ◆ identifies solutions and sets specific goals for the year
- ◆ prepares an annual action plan for delivering improvements in the coming year
- ◆ monitors implementation
- ◆ starts back at the beginning again with another review the following year.

Setting Goals

Three types of goals are required: targets, recommendations, and longer-term objectives.

i. Targets

Targets guide the work of the HTM Team, HTM Working Group (or its sub-groups) and user departments during the following year. They help to improve services and make sure that the most important work gets done. Targets are one of the best tools for judging progress and work performance. We suggest that each group/department should have between five and 10 targets, following the ‘SMART’ target-setting process:

Specific	state what should be done and who will do it
Measurable	easy to measure, or easy to decide that the target has been achieved or if progress is being made
Achievable	possible to carry out with existing staff, equipment and money
Relevant	cover a priority problem or improvement
Time-bound	state when the activity should be completed by.

It will be clearer if targets are written down using the following headings, which can be used when the final plans are produced:

Target	By whom	How to measure	How to achieve	Timetable
Actions agreed, listed in order of priority	Names of persons who will be responsible	How progress will be determined (see indicators below)	Resources required	Time-frame for start and completion

ii. Recommendations

You will discover that some important problems cannot be overcome or improvements achieved unless extra supplies, staff, or funds are provided, or unless assistance is obtained from outside. In such cases, recommendations are required. These should be:

- Specifically addressed to the person, official, department, organization, etc that is able to carry out the recommendation.
- Reasonable there is no point in asking for the impossible, such as 10 times more staff.
- Essential there should be no easy way for the HTM Team to achieve the same results on their own.

iii. Longer-term objectives

You will also discover some problems which cannot be solved in one year. Maybe they need large amounts of money, longer preparation, or plenty of time to achieve. Or maybe it is simply not possible to do everything at once. In such cases, longer-term objectives are required which will be carried forward to the next year, or for implementation later on.

How to Measure the Goals

Each goal must be easily measured, so that you can see if it has been achieved or if progress is being made:

- ◆ You need a way of determining if you are moving towards your goal – this is called an *indicator*. There will always be several possible indicators for each goal, and more than one way of measuring them.
- ◆ You need to know where you are starting from, in other words, what the situation is now – this is called the *baseline data*. The data chosen must be relevant to the indicator.

Box 35 provides an example of different ways of measuring a goal using indicators and baseline data.

BOX 35: Example of How to Measure a Goal

Goal: Stop wasting water – cut the health facility water bill

An indicator: Reduction in the number of leaking taps

One way of measuring this:

Calculation required: Percentage of reported leaking taps fixed per month

$$= \frac{\text{Number of leaking taps fixed in a month}}{\text{Number of leaking taps reported in that month}} \times 100 \%$$

Baseline data: In a study of the current situation you find that 20 taps were repaired in October, but 60 were reported as leaking.

Therefore your baseline data is 33%.

Your aim is to improve this situation and increase this percentage.

Alternative way of measuring this:

Baseline data: In a study of the current situation you find that 20 taps are too old, and you plan to replace half of them in the next three months. An additional 30 taps could be renovated with new washers, and you plan to do them all in the next three months.

Calculation required: Percentage of faulty taps replaced

$$= \frac{\text{Number of old taps replaced in a time period}}{\text{Number of old taps you planned to replace in that time period}} \times 100 \%$$

and percentage of faulty taps renovated

$$= \frac{\text{Number of old washers replaced in a time period}}{\text{Number of old washers you planned to replace in that time period}} \times 100 \%$$

After three months you find that, in fact, you only managed:

- ◆ to replace five taps, that is, 50% of your first target
- ◆ to replace 20 washers, that is, 66% of your second target.

It is necessary to choose suitable indicators that are specific to all your annual goals. There are many possible indicators for HTM Teams, the HTM Service, and the health service as a whole, so staff and managers should decide upon the most important activities (or statistics and results) to measure.

Examples of the types of indicators which can be used for equipment maintenance are those describing:

- ◆ the existing situation
 - numbers of pieces of broken equipment
 - down-time (time between a machine breaking down and functioning satisfactorily again)
 - key spare parts available and used
- ◆ improved performance
 - number of accident-free driver days
 - response time by the HTM Team when faults are reported
 - numbers of maintenance staff attending training courses
 - increase in the number of PPM interventions
- ◆ cost-benefits
 - down-time when PPM implemented compared to down-time when there is no PPM
 - lost income due to malfunctioning equipment
- ◆ efficiency and effectiveness
 - equipment availability per year (for different types of equipment)
 - productive time worked by maintenance staff compared to total time present (for more on productivity see *Guide 6* on financial management).

The HTM Teams and HTM Working Groups should meet to agree on a few suitable indicators that can be measured easily and quickly (if possible). Positive indicators are preferable as they motivate staff. Sometimes it is useful to use common indicators for different teams, groups, and staff, so that their progress can be compared.

Once the indicators have been agreed, they need regular measuring and charting.

The relevant Health Management Team will need to decide:

- ◆ how records of these indicators will be kept, for example, in a register, with a form, or on a chart (*Section 8.2*)
- ◆ who will be responsible for keeping them
- ◆ how regularly the results will be summarized (each month, for example)
- ◆ what form of charts and displays you will use to display the monthly summarized results (so that it is easy for people to see how they are progressing).

The Annual Planning Process

In preparation for the annual action planning process, every HTM Team, HTM Working Group, and sub-group should be involved in carrying out a review of:

- ◆ their performance and progress in the previous year
- ◆ their targets, plans, and needs for the coming year.

HTM Managers or Chairs of Sub-Groups should involve their staff through regular meetings. Alternatively, if the team is large, they can nominate a small review group to prepare material for the action planning process. It is useful for each group to undertake an exercise which involves asking a selection of their 'clients' about the team's work. Thus an HTM Team or sub-group will ask their clients what they think are the five most important problems regarding equipment and its maintenance.

These clients should be a mixture of:

- ◆ staff in the health facility or decentralized health authority served by the HTM Team or sub-group
- ◆ members of the Health Management Team at their facility or health authority level
- ◆ the HTM Service
- ◆ patients.

If targets were prepared the previous year, they should be assessed to see how well they were implemented. This helps the HTM Team or sub-group to identify and study the successes and problem areas for the team, and agree on which problems are priorities for tackling in the coming year.

The HTM Team or sub-group should now have prepared sufficient information to take to the annual action planning seminar. If the seminar is a large one (in other words, it covers many HTM Teams or health facilities), the HTM Manager or Chair of Sub-Group may have to nominate a couple of senior, knowledgeable and responsible members of staff to be their representatives at the meeting.

Depending on the number of people attending, the seminar may be a one- or two-day event, as described in *Box 36*. For each priority problem area identified, delegates at the seminar will consider and discuss the issues raised and come up with suggestions for solutions. For each solution or improvement, representatives write new targets, recommendations, and longer-term objectives, as well as indicators for the coming year (as described above).

The Annual Action Plan developed should state the agreed goals, who is responsible for achieving these goals, how they will be measured, the resources required, and the timescale by which they should be achieved. Once the plan is ready, it needs to be communicated to all staff.

BOX 36: Strategies for Running an Annual Action Planning Seminar in the Health Service

All managers (including those in the HTM Service) ensure that their nominated representatives attend the annual action planning seminar.	
<i>Process</i>	<i>Actions</i>
<p>The first half day to one full day Participants are divided into working groups.</p> <p>Each working group is given different departments or areas of the health service to consider.</p> <p>Each working group analyzes their department/area under study.</p>	<p>No more than 10 people in each group (with a mix of nurses, doctors, and other staff), in order to improve participation.</p> <p>They are given the material prepared by those departments (as described earlier in this Section).</p> <p>They: ♦ review performance over the past year ♦ assess how well targets were implemented ♦ consider the lists of problems and solutions provided ♦ identify successes ♦ carefully examine problem areas.</p>
<p>Each working group prepares a list of:</p> <ul style="list-style-type: none"> ♦ between five and 10 most important difficulties or problems for the department/area; ♦ their five to 10 targets, recommendations, and longer-term objectives. 	<p>They take large sheets of paper, with the name of the working group on top, and from their analysis they clearly list:</p> <ul style="list-style-type: none"> ♦ the priority problems ♦ the targets, recommendations, and longer-term objectives.
<p>The second half day to one full day The participants are brought together in a plenary session.</p> <p>Each working group presents its findings in turn.</p> <p>Participants from other groups provide input.</p> <p>The Chair oversees an end-result of the plenary session.</p>	<p>The purpose is to reach agreement on all proposed targets, recommendations, and longer-term objectives by the end of the seminar.</p> <p>They display and briefly explain their list of problems, targets, recommendations, and longer-term objectives.</p> <p>They put forward questions, advice, and suggestions for amendments.</p> <p>He or she ensures that agreement is reached for all goals.</p>
<p>After the seminar The Health Management Team reviews and finalizes the material from the seminar.</p> <p>The Health Management Team distributes the Annual Action Plan.</p> <p>Heads of Department, HTM Managers and Chairs of Sub-Groups display their goals.</p>	<p>It: ♦ reviews the materials generated at the seminar ♦ arranges them appropriately in order to produce the Annual Action Plan ♦ combines duplicated suggestions from different working groups ♦ writes any additional goals required ♦ makes revisions as necessary ♦ groups together all targets, recommendations, and longer-term objectives by team/department and subject.</p> <p>It ensures that the Annual Action Plan is reproduced quickly and distributed widely around the service, so that all staff have access to it.</p> <p>They ensure the goals are displayed in suitable locations, to ensure that staff are aware of them.</p>

Development Projects Related to Healthcare Technology

Any health facility, district health authority, or HTM Service may be involved in a large development project, which can be donor-funded. Such a project may be set up across many sectors in the health service, and if it involves a healthcare technology component the HTM Service must be involved. Such a component could address a number of healthcare technology issues, such as:

- ◆ the purchase of equipment
- ◆ improvements to health facilities
- ◆ improvements to the HTM Service
- ◆ support for healthcare technology management.

The healthcare technology component could apply across the health facility, the district, or the health service as a whole, and over a longer time span than one year. Such a project will usually have goals of its own which are different to the departmental ones set annually.

It is important to remember that such projects are often financed by external support agencies which may have their own requirements for the goals, and the time frame for reaching them. The HTM Working Group, or possibly a smaller project sub-group (*Section 1.2*), should set goals and oversee the progress of the healthcare technology component. It should use the principles provided concerning setting targets, recommendations, and longer-term objectives (as detailed in this Section), in consultation with the external support agency. For each element of the healthcare technology component of any development project it is necessary to:

- ◆ set goals and measurement indicators
- ◆ agree the time frame for reaching the goals set
- ◆ monitor progress
- ◆ report to the external support agency as required by them.

8.2 MONITORING PROGRESS WITH EQUIPMENT MAINTENANCE

Part of the management of equipment-related activities is the identification of problems and needs. All equipment-related activities should be monitored and evaluated, and the performance of equipment, staff, and departments should be supervised (this applies to all clinical, technical, and support departments). The results of such monitoring are useful for providing feedback to staff, Health Management Teams, and the Healthcare Technology Management Service.

Monitoring progress involves a number of different activities. The following monitoring activities are described in this Section:

- ◆ Monitoring progress against the annual goals (as set in *Section 8.1*).
- ◆ Monitoring progress in general, using statistics.
- ◆ The audit process for development projects.

Monitoring Progress Against Annual Goals

Monitoring progress against goals is one of the best ways that staff, managers, and the health service provider can judge their work performance. Thus, it is necessary to follow up the plans and goals set, in order to ensure that they are put into practice. If this is not done and goals sit on a shelf gathering dust, then all the time spent planning will have been wasted.

Regular monitoring of progress against goals is essential throughout the year. This should be done using the measuring and charting methods introduced in *Section 8.1*. Displaying annual goals and progress towards them can be helpful to staff.

At the end of each year, it is essential to review and carefully analyze the results achieved on all the team goals, before starting to develop the Annual Action Plan for the following year. This step is the most important – to review results on a regular basis **with the people who are doing the work**.

This is the time to give praise for good progress, or to find out what might be causing shortcomings or problems, and then seek a solution. If solutions are quite impossible it may be necessary to change the plans. If common indicators were used for different teams, groups, and staff, it will be possible to compare their progress.

Once planning and financial systems are established, it is also possible to link annual planning with the process of setting the health facility's budget. For example, the fact that an HTM Team achieves its goals could play an important part in justifying the budget allocations they request from the Health Management Team (see *Guide 2* on planning and budgeting).

Monitoring Progress in General

Since monitoring equipment-related activities helps to identify problems and needs, the results of monitoring can usefully provide feedback to staff and senior management (*Section 7.2*). Thus, regular monitoring of activities and services is essential for improving the quality of healthcare. Management need facts so that they can plan effectively, and need to know how equipment-related activities are performed.

Thus, it is important to have some method of collecting information, such as:

- ◆ the numbers of equipment not functioning
- ◆ spare parts and maintenance material usage rates
- ◆ resource constraints
- ◆ skills and training deficiencies.

It may be possible to incorporate this data gathering into a Maintenance Information System as part of the existing Health Management Information System (see *Guide 1* on organizing HTM). This will enable 'evidence-based' planning to take place.

HTM Managers (and Chairs of Sub-Groups) need to gather and compile statistics regularly. These will provide information on the progress of their team and its work performance in relation to equipment. They need to gather this data in order to:

- ◆ be better managers
- ◆ improve the running of their teams
- ◆ provide information to other people and bodies who need to know how their team is performing.

Thus the HTM Manager (Chair of Sub-Group) needs to:

- ◆ analyze completed Work Request/Job Forms and various files (*Section 4*), in order to extract information about problems with equipment, procedures, staff, or resources
- ◆ use data from the maintenance record system to compile statistics about the condition of equipment, HTM activities, and the performance of the HTM Team
- ◆ produce brief, informed and accurate written reports for the Health Management Teams and the HTM Service on pertinent equipment maintenance issues (*Section 7.2*).

Statistics should be gathered regularly, for example on a monthly or quarterly basis. *Box 37* shows the sort of statistics that can be gathered. You will need to decide which are the most useful ones for your health service.

The HTM Manager should gather the completed Work Request/Job Forms (*Section 4.3*) on a regular basis (every week or month, for example) in order to analyze their contents. He or she can extract and record maintenance statistics from these forms (and other general ledgers) on the issues determined to be important.

The compilation of these statistics is made easier if you design relevant and useful Statistics Forms to enter the data into. *Figure 25* shows examples of the types of forms which could be used to present useful data. You will need to adapt and modify the forms shown in order to make them workable for your needs, and you will need to create additional ones as required. We suggest that you file these Statistic Forms in Statistics Folders (see *Box 17*), and that you use them for creating reports for senior management (*Section 7.2*).

The results from the statistics gathered can also be used to measure the performance of the HTM Team, their productivity, and how economical they are. For more details on these procedures see *Guide 6* on financial management.



- Tip**
- Simple collection of statistics does not improve performance. The statistics must be interpreted by managers with a certain amount of worldly wisdom. Staff will be aware that they are being monitored and may try and alter their performance to hit whatever targets are being monitored.
 - The gathering of statistics also needs to be introduced with care and at a pace at which their effects can be observed. They should not be introduced all at once.

BOX 37: Examples of Statistics Which Can be Gathered Regularly

Type of statistics	Examples
Statistics obtained by counting numbers	<p>The workload and performance of the HTM Team, such as:</p> <ul style="list-style-type: none"> ◆ the number of jobs received by different sections (electrical, mechanical, plumbing, biomedical, etc) (see <i>Figure 25</i>) ◆ the number of jobs completed by different sections ◆ the number of jobs still outstanding. <p>The number of jobs delayed due to different causes (see <i>Figure 25</i>), such as:</p> <ul style="list-style-type: none"> ◆ spares not available ◆ no money to buy materials ◆ low staffing levels ◆ no access to transport ◆ specific tools unavailable ◆ restricted access to the equipment in the user department ◆ poor response time of the service contractor. <p>The number of breakdowns due to different causes, such as:</p> <ul style="list-style-type: none"> ◆ poor quality equipment ◆ poor workmanship by maintainers ◆ user problems ◆ service history/old age. <p>The frequency of breakdown for different types of equipment.</p> <p>The departments where problems are most frequent (see <i>Figure 25</i>).</p> <p>The number of times external contractors are called out.</p> <p>The skills available (or absent) among the maintenance staff.</p>
Statistics obtained by doing calculations	Use of internal resources, for example labour time of the in-house team compared to total maintenance costs.
Statistics obtained by doing analysis	This method is used for things that are more difficult to measure or assess and refers to the quality of performance and user satisfaction rather than quantities.

Figure 25: Types of Forms Which Can Be Used for Gathering and Presenting Statistics for a Set Time Period

Example of statistics to show how busy different sections are

NUMBERS OF JOBS BY SKILL TYPE/SECTION:				
Electrical	Plumbing	Carpentry	Medical	Medical
2	2	2	2	6

These figures may be useful for highlighting where more technical staff are needed, where there may be user problems, or where there may be poor building infrastructure.

Example of statistics which show where the major problems are

NUMBER OF PROBLEMS BY LOCATION:		
Female Ward	Laundry	Laboratory
0	2	6

Or

NUMBER OF PROBLEMS BY LOCATION:				
	Female Ward	Male Ward	Theatre	Casualty
Suction Pump	0	0	2	6
Examination Light	4	3	5	4

These figures may be useful for highlighting where there may be user problems, a need for training, or a need to replace old equipment.

Regular monitoring of equipment-related activities will also mean that instances of good or bad work performance, in relation to equipment, can be incorporated into the staff appraisal system (*Section 7.3*). Staff such as the In-Service Training Coordinator and the Infection Control Officer can also play a role in monitoring equipment skills and issues across the health facility as a whole. This helps them to identify where problems are occurring which they could follow up with in-service training or other measures (*Section 7.4*). In addition, HTM Managers should regularly report to the Purchasing and Supplies Officer regarding the quality of materials purchased (*Section 6*), and the performance of external maintenance contractors (*Section 3.5*).

The Audit Process for Development Projects

In the case of large (donor-supported) development projects, the project sub-group will have prepared the goals for each element of the healthcare technology component (*Section 8.1*). Depending on the aspects being developed, different elements will be under scrutiny. Here are some examples.

If equipment is being purchased, you may need to monitor progress with:

- ◆ equipment procurement procedures
- ◆ site preparation work
- ◆ installation, commissioning, and acceptance procedures
- ◆ the stores system for equipment components
- ◆ training of maintainers and users
- ◆ utilization of new equipment.

If the maintenance service is being improved, you may need to monitor progress with:

- ◆ maintenance staffing levels
- ◆ workshop facilities – rooms, tools, technical literature
- ◆ maintenance systems – development of records, PPM, statistics, etc
- ◆ maintenance budgets
- ◆ maintenance contracts
- ◆ rehabilitation work.

If equipment management is being improved, you may need to monitor progress with:

- ◆ the formulation of equipment development plans
- ◆ technical participation in health service management
- ◆ development of management ‘tools’ such as an equipment inventory, specifications, and job descriptions
- ◆ training and development plans for the improvement of management skills.

Indicators will have been chosen to measure progress with the goals for such elements. A standard Audit Form can be developed based on this monitoring structure, containing:

- ◆ a list of the healthcare technology elements involved
- ◆ the aspects being developed for each element
- ◆ a record of the progress made (possibly entered against a record of the goal set)
- ◆ a record of the date the audit was taken.

Such an Audit Form ensures continuity and consistency with subsequent audits of the project. An Audit Process can be developed and agreed, and an Audit Team established to monitor progress regularly.

Box 38 contains a summary of the issues covered in this Section.

BOX 38: Summary of Procedures in Section 8 on Action Planning and Reviewing Progress

Setting Goals	Health Service Provider	<ul style="list-style-type: none"> ◆ ensures there is an annual action planning process whether across ‘horizontal’ levels (within a health facility or district), or within a ‘vertical’ programme (for the HTM Service as a whole)
	HTM Teams and HTM Working Groups	<ul style="list-style-type: none"> ◆ set their targets, recommendations, and longer-term objectives each year, in order to improve their performance (after reviewing the previous year’s performance) ◆ develop suitable measurement indicators for these goals and gather baseline data (see Box 35) ◆ participate in the annual action planning seminar
	Health Management Teams (or their Project Sub-Group)	<ul style="list-style-type: none"> ◆ set the targets, recommendations, and longer-term objectives for any development projects relating to equipment, in consultation with the external support agency ◆ develop suitable measurement indicators for these goals
Monitoring Progress	Health Service Provider	<ul style="list-style-type: none"> ◆ ensures the Health Management Information System is developed to include factors which measure progress with equipment
	HTM Managers (at all levels of the HTMS)	<ul style="list-style-type: none"> ◆ ensure progress against annual goals is monitored, displayed, and used to provide feedback to team members, as well as to develop improved goals for the following year ◆ design suitable statistics which are informative and easy to gather (see Box 37) ◆ use the maintenance record system for gathering and compiling statistics, enter them on Statistics Forms, and file them in Statistics Folders ◆ use the statistics when reporting to management ◆ monitor staff’s good and bad performance, and feed it into the staff appraisal system
	Health Management Teams (or their Project Sub-Group)	<ul style="list-style-type: none"> ◆ ensure that progress against any goals (annual, regular, or project) is used to prompt the correct response, such as training, better budgets, different suppliers, career progression, etc ◆ ensure progress against project goals is monitored and reported as required by the external support agency

ANNEX 1: GLOSSARY

Acceptance process:	Activities undertaken when equipment arrives at an health facility, at the end of which the equipment will be operational and officially belong to the facility, such as receipt, unpacking, installing, commissioning, initial training, entering into stores and onto records, payment.
Accessories:	For equipment, those items which connect the machine to the patient (e.g. leads, probes), assist with the use of the machine (e.g. trays, foot-switches), or adapt its performance (e.g. adaptors, lenses).
Administrative level:	See decentralized authorities.
Autonomous:	Self-governing or independent.
Budget:	A written financial plan listing future, known, or estimated income and expenditure covering a given period of time, for example a year (annual budget).
Calibration	The comparison of the readings of a piece of equipment with those of a standard, followed by any adjustments required to ensure the equipment's performance meets the standard.
Capital budget:	Planned expenditure on capital items (such as buildings, equipment, vehicles) which require substantial (possibly one-off) payments in a year, and should not be included in the recurrent (or operational) budget.
Central level:	Highest authority of your health service provider, such as Ministry of Health or Board.
Commissioning:	A series of tests and adjustments performed to check whether, and ensure that, new equipment is functioning correctly and safely before being used.
Communication equipment:	Any equipment that is used for sending or receiving information, such as telephones, two-way radios, nurse-call systems, paging systems.
Consumables:	For equipment, those items which are used up during the operation of equipment (e.g. film, reagents, gel).
Contract:	A written agreement for work to be done by another person or organization, which is intended to be enforceable by law.
Craftsperson:	A skilled person who works with their hands; someone with craft skills such as a plumber, carpenter, and electrician; ranges from someone with informal training (such as a handyman) to trade test holders at various levels (known as 'artisans').
Decentralized authorities:	Local units of an organization which have had authority transferred to them from the central level of the organization. For example, district, regional, provincial or diocesan health authorities.
Decommission:	Take out of service; dismantle and make safe; board. The process of condemning or writing off equipment and disposing of it.
Donor:	See external support agency.
Energy sources:	A source of energy or power, such as generating sets, solar panels or transformers.

Engineer:	Someone qualified in a branch of engineering such as electrical, mechanical, or electronics, with advanced academic knowledge of controlling, designing, and building equipment, and using their skills to develop original ideas; ranges from someone with a higher national diploma from a technical college to someone with a bachelor degree in engineering.
Equipment-related supplies:	Items which are essential for equipment use, such as consumables, accessories, spare parts, and maintenance materials used with equipment.
Equipment users:	All staff involved in use of equipment, such as clinical staff (e.g. doctors and nurses), paramedical staff (such as radiographers and physiotherapists) and support services' staff (such as laundry and kitchen workers)
Establishment posts	Available jobs within an organization that staff can be appointed to.
External support agency:	A body responsible for providing money, equipment, or technical support to developing countries on various terms, such as international donors, technical agencies of foreign governments, non-governmental organizations, private institutions, financial institutions, faith organizations
External support agency staff:	People working for external support agencies that health workers come into contact with, such as a country representative, desk officer, consultant, coordinating agency, director
Fabric of the building:	Items which are part of the integral structure or framework of a building, such as doors, windows or roofs.
Facility:	See health facility
Fire fighting equipment:	Equipment used to put out fires, such as fire blankets, buckets, extinguishers, hose and sprinkler systems
Fixtures built into the building:	Items which are not part of the integral structure of a building but are installed into the fabric of the building, such as ceiling-mounted operating theatre lights, scrub-up sinks and fume cupboards.
Head of section:	Departmental manager, such as head of department, group leader, officer in-charge, senior operator
Health facility:	Buildings where healthcare is delivered, ranging from small units (clinics, health centres), and small hospitals (rural, district, diocesan), to large hospitals (regional, referral)
Health facility furniture:	Furniture with a specific clinical use in health facilities, such as beds, cots, trolleys, infusion stands.
Health management team:	Health management body, such as facility management committee, district/regional/diocesan/central health management team, Board
Health service provider:	A provider of health services, such as Ministry of Health or Defence, non-governmental organization, private institution, employer organization or corporation (for example, mine), faith organization
Health system:	Comprises all organizations, institutions, and resources devoted to health actions (defined as any effort, in personal or public health services or through intersectoral action), whose primary purpose is to improve people's health (Source: WHO).

HTM Manager:	Head of the HTM Team; ranging from a general member of health staff with some management skills in the smallest HTM Teams, to an engineering manager in the highest level of HTM Team.
HTMS:	Healthcare Technology Management Service made up of a network of HTM Teams and HTM Working Groups
HTM Team:	A body responsible for the management of equipment, such as, equipment management team, maintenance management team, physical assets management team; part of the HTM Service.
HTM Working Group:	A working group, or standing committee responsible for making decisions on healthcare technology management issues; part of the HTM Service.
Indicator	Something that will provide information which shows whether progress is being made towards achieving a goal.
In-house:	Activities undertaken by staff already employed by the health service provider organization (rather than using temporary hired labour or external contractors).
Installation:	The process of fixing equipment into place; can range from building equipment into the fabric of a room to simply plugging it into an electrical socket.
Inventory:	A systematic listing of stock (or assets) held. An <i>annual inventory</i> is prepared at the end of each year following a physical inspection and count of all items owned by an organization. The list gives details, such as location, reference number, description, condition, cost, and the date the inventory was taken.
Laundry and kitchen equipment:	Equipment required for kitchen or laundry activities, such as cookers, cold rooms, washing machines, hydro-extractors, roller-ironers.
Lifetime:	Lifespan, life expectancy. For equipment, the likely length of time that an item will work effectively, dependent on the type of technology and parts used in its manufacture.
Maintainers:	See maintenance staff.
Maintenance materials:	Those items used up during the maintenance of equipment, and generally available from many sources (e.g. washers, oil, fuses, paint).
Maintenance staff:	Staff responsible for maintenance of equipment, such as craftspeople, artisans, technicians, technologists, engineers.
Manager:	Any staff involved in the management of equipment-related activities. This could include administrator, nurse-in-charge, medical superintendent, chief executive, director, health secretary, medical practitioner, maintenance manager, policy-maker.
Medical equipment:	Equipment used for medical purposes, including X-ray units, diathermy units, suction pumps, foetal doppler, scales, autoclaves, infant incubators, centrifuges.
Office equipment:	Equipment used in an office, such as computers, photocopiers, calculators, record systems.
Office furniture:	Furniture used in an office, such as desks, chairs or filing cabinets.

Outreach:	When an organization travels out from its base to undertake work amongst the community it serves.
Outsource:	Obtain something (such as a service) by contract from an outside supplier; contract work out to an external agency.
Pending:	Awaiting an outcome; waiting for something to take place.
Plant, general:	Machinery such as boilers, lifts, air-conditioners, water pumps or compressors.
Quality control:	A system of maintaining standards; testing a sample against specifications.
Recurrent budget:	Planned expenditure on recurrent items for ongoing monthly needs, such as drugs, materials, spare parts, food, fuel, which should not be included in the capital budget.
Rehabilitate:	Restore to a former state; renovate; undertake major repair work to return an item to a working condition.
Safety testing:	A series of procedures undertaken to establish that equipment is in a condition which is safe for the operator and patient.
Service history:	A record in date order (history) of the maintenance and repair work (service) undertaken on a piece of equipment over time.
Service supply installations:	Supply installations such as electrical installations, water and sewage pipelines, gas supplies.
Spare parts:	For equipment, those items which make up the machine, need replacing as they wear out, and may be specific to a particular model (e.g. bearings, bulbs, printed circuit boards).
Standard:	A required or agreed level of quality attainment set by a recognized authority, used as a measure, norm, or model for all aspects of health services and healthcare technology.
Standardization:	Rationalization, normalization, and harmonization. In other words, reducing the range of makes and models of equipment available in stock, by purchasing particular or named makes and models.
Stock:	In stores, this is the goods held by an organization for its own use. The 'equipment stock' is all the equipment assets owned by an organization.
Supplier:	Someone who provides equipment, such as a manufacturer, manufacturer's representative, wholesaler, salesman.
Support staff:	Additional types of staff in the health service besides medical personnel, such as planner, finance officer, procurement officer, stores controller, human resource officer.
Technician:	Someone skilled in a craft such as plumbing, carpentry, electricity, with academic knowledge of how to put the science of their skills into practice. Ranges from someone with a craft certificate at various levels from a vocational training college, to someone with a basic-level technical diploma from a technical college.
Technologist:	Someone skilled in a craft such as plumbing, carpentry, electricity, with considerable academic knowledge of how to put the science of their skills into practice; someone with a technical diploma from a technical college.

Trade testing:	Training and examinations at various levels carried out by a Trade Test Authority in a range of nationally recognized skills used by artisans/craftspeople, which are known as ‘trades’ (such as plumbing, masonry, electrics, carpentry).
Training equipment:	Equipment required when running training courses, such as overhead and slide projectors, video and tape recorders.
Users:	See equipment users
Vehicles:	Any conveyance used for transporting people, goods, or supplies in the health service, such as ambulances, cold-chain motorbikes, mobile workshops, lorries, buses.
Walking aids:	Items used to aid mobility, such as wheelchairs, zimmer frames, crutches.
Waste treatment plant:	Any plant used to treat waste, including incinerators, septic tanks or biogas units.
Working group	A group of people set up to be responsible for a particular subject area, such as a standing committee, select committee, sub-committee
Workshop equipment:	Equipment used in a workshop, such as hand tools, bench tools or test instruments.
Your organization:	See health service provider.

BOX 39: WHO’s Definition of the Technology Management Hierarchy

Equipment support:	undertaking maintenance and repair.
Equipment management:	using the equipment database (inventory and maintenance history) to help you make decisions for improving equipment support.
Asset management:	including cost and utilization information (life-cycle cost analysis) in the equipment database to help you make decisions on replacement and acquisition.
Technology assessment:	reviewing past, current, and future technologies to determine their efficacy and effectiveness, and to help you make decisions for capital planning and acquisition.
Technology management:	using: <ul style="list-style-type: none"> equipment equipment support equipment management asset management technology assessment to manage technology in health care from conception to retirement.

Source: Department of Health Service Provision, World Health Organization, 2000

ANNEX 2: REFERENCE MATERIALS AND CONTACTS

This Annex is in two parts, and provides information about:

- Part i. Books, guidelines, databases, and websites
- Part ii. Organizations, sources of publications in *part i*, resource and information centres, and training institutes.

i. Books, Guidelines, Databases, and Websites

The following books, guidelines, videos, databases, and websites are listed in subject categories according to the topics found in Sections of this Guide. For each publication, a brief description of the content and the main source(s) are included. Contact details for the source organizations are included in *Part ii*. Readers should note that many of the publications are available at low cost. In some countries it may also be possible to obtain these publications from local bookstores, as publishers and distributors increase efforts to ensure wider availability. Published prices may be flexible depending on the order size, discounts available and distribution method.



- Tip** • Many books and documents cover a variety of topics that appear in several Sections of this Guide. The first time they appear in this list they are described in full. For each subsequent entry only the basic details are provided.

Healthcare Technology Management Framework Issues

This material covers issues in *Sections 1 and 2*, such as healthcare technology management definitions, policy, regulations, guidance, and services. It is listed alphabetically by title. Further detailed information on this topic is provided in *Guide 1*.

Developing healthcare technology policy

Health care technology management No.1: Health care technology policy framework
Kwankam Y, Heimann P, El-Nageh M, and M Belhocine (2001). WHO Regional Publications, Eastern Mediterranean Series 24. ISBN: 92 9021 280 2

This booklet is the first in a series of four titles. It introduces the ideas of and behind health care technology management, defines terms relating to and sets objectives for health care technology management policy. It examines what should go in to such a policy, and the national policy framework and organization. Capacity-building and human resources issues are considered, as well as economic and financial implications. Attention is also given to legislation, safety issues, cooperation nationally and between countries, implementation, monitoring, and evaluation. See *Guide 1* for information on the three further titles in this Series:

No.2: Eastern mediterranean regional strategy for appropriate health care technology

No.3: Health care technology policy formulation and implementation

No.4: Country situation analysis.

Available from: WHO

Interregional meeting on the maintenance and repair of health care equipment: Nicosia, Cyprus, 24-28 November 1986

WHO (1987). WHO document WHO/SHS/NHP/87.5

This document provides a comprehensive discussion of the problem of non-functioning equipment and of proposed solutions. The major policies, recommendations, and strategies proposed by the conference on the issue of maintenance and repair of health care equipment are presented. It includes four Working Papers which cover in detail: maintenance and management of equipment, the proposed health care technical service, manpower development, and training.

Available from: WHO

Management of equipment

DHSS, UK (1982). Health Equipment Information No. 98

The aim of this booklet is to recommend a system of equipment management that, if fully implemented, would ensure that all equipment used in the British National Health Service was suitable for its purpose, was maintained in a safe and reliable condition, and was understood by its users. Its recommendations and procedures are structured into sections on equipment selection, acceptance procedures, training, servicing (maintenance, repair, and modification), and replacement policy. It also covers the management of inventories, equipment loans, servicing, long-term commercial contracts, infection hazards.

Available from: Her Majesty's Stationery Office (HMSO).

Medical equipment in sub-saharan Africa: A framework for policy formulation

Bloom, G and C Temple-Bird. (1988). IDS Research Report Rr19, and WHO publication

WHO/SHS/NHP/90.7. ISBN: 0 903354 79 9

This book provides a good overview of the situation of medical equipment in Africa. Its approach to the analysis is to unpackage medical equipment technology into its component activities, such as planning, allocating resources, procurement, commissioning, operation, maintenance, training, etc. It provides good general policy formulation strategies to address the problems discussed.

Available from: WHO

Practical steps for developing health care technology policy: A manual for policy-makers and health service managers in developing countries

Temple-Bird, C (2000). Institute of Development Studies, University of Sussex, UK. ISBN: 1 85864 291 4

This book is a practical step-by-step guide for developing health care technology policy. It can be used by health service providers, regional and district health authorities, health facility managers, and external support agencies. It describes a process for developing health care technology policy which is collaborative, participatory, iterative, and involves community stakeholders. Guidance is provided on underlying management concepts, undertaking a situation analysis, running a ideas workshop, formulating policy, developing an implementation plan and procedures manual, as well as the resources required to complete these tasks.

Available from: Ziken International Consultants Ltd

See *Guide 1* for further resources on, and examples of, developing healthcare technology policy.

Regulating relationships with external support agencies that provide equipment**Guidelines for health care equipment donations**

WHO (1997). WHO document WHO/ARA/97.3

This document presents guidelines that aim to improve the quality of equipment donations, not to hinder them. They are not an international regulation, but intended to serve as a basis for national or institutional guidelines, to be reviewed, adapted and implemented by governments and organizations dealing with health care equipment donations. They provide detailed guidance and checklists for both the potential donor and recipient. The guidelines are based on extensive field experience and consultations with many experts internationally. They also merge together several earlier documents, including the one listed below.

Available from: WHO

Guidelines on medical equipment donations

Churches' Action for Health (1994). World Council of Churches' publication

This paper is a guide for those accepting and making donations, and is also useful for those planning to buy equipment. It clearly lays out in point form the responsibilities of the recipient and the responsibilities of the donor.

Available from: WCC

Understanding healthcare technology management

International seminar for hospital technicians/engineers: February 1998, Moshi, Tanzania

Clauss J (ed) (1998). FAKT

This document reports the results of intensive work by 38 national and international experts brought together from faith, public, and private agencies to strengthen equipment management measures in the health sector. It includes papers, with country examples, on healthcare technology management, financing maintenance, workshop and tool requirements, cash control, equipment standardization, networking, structures of health care technical services, training, communication technologies, modification of medical and hospital equipment, and energy supply and photovoltaics.

Available from: FAKT

International workshop on healthcare technology management: 2-6 October 2000, Catholic Pastoral Centre, Bamenda, Cameroon

Clauss, J (compiler) (2000). FAKT

This document reports the results of intensive work by 35 national and international experts involved in setting up and operating systems for the sustainable management of healthcare technology. It includes papers, with country examples, on healthcare technology management, the role of stakeholders, public/private partnerships for providing HTM, cost-effective maintenance and repair services, and acquisition and utilisation of healthcare technology.

Available from: FAKT

Medical equipment in Botswana: A framework for management development

Temple-Bird C L, Mhiti R, and G H Bloom (1995), WHO publication WHO/SHS/NHP/95.1

This book reports on the results of a study of the healthcare technology sector in Botswana, and the lessons learnt are of relevance to many other countries. The study was undertaken by unpackaging the sector into its component activities, such as planning, allocating resources, procurement, commissioning, operation, maintenance, training, etc. In this way, the book provides good general healthcare technology management strategies to address the problems discussed. This book also describes how technical staff obtain their basic technical qualifications either as artisans at local Trade Testing Centres, or as technicians at the local Polytechnic, and provides an understanding of how such systems and qualifications work.

Available from: WHO

Medical technology management

David Y, and T Judd. (1993) BioPhysical Measurement Series, SpaceLabs Medical Inc.

ISBN: 0 9627449 6 4

This book looks at the appropriate management tools needed to make technology's role more clinically effective and cost-effective (based on the healthcare delivery system in the USA). It focuses on strategic technology planning principles, and how they contribute to improved patient outcomes. It also looks at a process for technology assessment and life-cycle cost analysis. It defines many common terms, and the role of useful committees, procedures, and forms.

Available from: SpaceLabs Medical Inc.

Physical assets management and maintenance in district health management

Halbwachs H (2000). GTZ document

This paper provides practical guidance to health workers involved in district health systems concerning health technology – one of the critical areas in managing health service delivery at district level. It presents the physical assets management approach, and elaborates on key strategies for maintenance, financing, quality control, monitoring indicators, and a basic paper-based maintenance information system. It also has an example of a maintenance job card.

Available from: GTZ

The effective management of medical equipment in developing countries: A series of five papers

Bastiaan Rimmelzwaal (1997). FAKT, Project Number 390

This document is aimed at the health workers, administrators, maintainers, and overseas aid workers who are involved in medical equipment management in developing countries. It examines the variation in performance with management of medical equipment in different countries, with the objective of identifying successful approaches. It addresses some of the managerial issues related to the conservation of equipment; allocation of human, financial and material resources; and acquisition and use. It looks at the structure for the HTM Service, and the HTM cycle.

Available from: FAKT

See *Guide 1* for more information on further relevant issues, such as health service definitions, the place of HTM in health systems, regulations, and standards.

Discussions on Maintenance

This material covers issues in *Section 1.2* on the importance and benefits of maintenance, *Section 2.2* on the resources required for maintenance, *Section 3.1* on priority setting and work allocation, *Section 3.5* on contract management, *Section 3.6* on outreach work, and *Section 4* on record-keeping. It is listed alphabetically by title.

Clinical engineering service departments: Establishment, scope of work and organization

Raab M (1999). Swiss Centre for International Health, Basle, Switzerland

This paper discusses the issues that prompted the evolution of clinical equipment support services, the resources and staff required when establishing clinical engineering service departments, and their scope of work, including details of necessary documentation and reporting using inventories and other recorded data, as well as acceptance testing of equipment.

Available from: SCIH

Computerizing maintenance for health care facilities in developing countries

Halbwachs H, and B Miethe (1994). GTZ, Eschborn, Germany

This book describes the documentation and analysis required if healthcare technology management is to be undertaken effectively (such as inventory management, planned preventive maintenance timetabling, costs analysis). It illustrates that for large stocks of equipment such work is made easier with the aid of computers. The book goes on to describe when and how to computerize equipment and maintenance records, including details of hardware and software requirements and products available. It includes details of the sort of data to be collected for effective healthcare technology management.

Available from: GTZ

Engineering and maintenance services in developing countries

Mehta JC (1983). In *Approaches to planning and design of healthcare facilities in developing areas, Vol 4*, Kleczkowski BM et al (eds). WHO Offset publication No 72. ISBN: 924 170072 6

This document is based on over 8 years of experience of the maintenance system in a government hospital in India. The document discusses maintenance for the hospital as a whole including buildings, plant, and equipment. There are many sections including ones on maintenance management, activities of the hospital engineering and maintenance department, planning the maintenance program, personnel, stores, services offered, PPM schedules for plant, and lists of cost estimates for maintenance (as a percentage of capital cost) for different types of healthcare technology.

Available from: WHO

Hospital engineering in developing countries

Dammann V, and H Pfeiff (eds)(1986). GTZ, Eschborn, Germany. ISBN: 3 88085 293 6

This is a report of a symposium held in 1983 in Giessen. It covers the constraints in developing countries, and requirements for establishing healthcare technical services. This includes discussions on defining maintenance and repair tasks, establishing maintenance records, equipping a workshop, and training of maintenance and user staff.

Available from: GTZ

Implementation guideline for physical assets management (PAM)

Department of Hospital Services (2003). Ministry of Health, Kingdom of Cambodia

The Cambodian Ministry of Health has developed its own healthcare technology policy, with assistance from a number of external support agencies. This implementation guideline for the policy contains a wide range of forms for assessing the state of existing facilities, supply installations, and equipment, requesting maintenance, assessing spare parts needs, and advice on workshop and tool requirements.

Available from: GTZ, Ministry of Health of the Kingdom of Cambodia

International seminar for hospital technicians/engineers: February 1998, Moshi, Tanzania

Clauss J (ed) (1998). FAKT

La maintenance dans les systemes de santé/ Maintenance for health systems: 4th GTZ Workshop, Dakar, Senegal, September 1993

Halbwachs H, and R Schmitt (eds) (1994). GTZ

This document reports the results of intensive work by 67 national and international experts brought together from health services and support agencies to strengthen equipment maintenance measures in the health sector. It includes papers, with country examples, on the benefits of maintenance, the place of maintenance in the district health system, maintenance management and organization, training requirements, energy management, photovoltaic systems, networking and computers, and record-keeping. The document has sections written in both French and English.

Available from: GTZ

Maintenance strategies

Raab M (1999), Swiss Centre for International Health

This paper discusses the main factors that can optimize maintenance strategies and gives some guidelines and examples from different countries, mainly those in transition. It looks at models and structures for providing HTM, and staff skill and workload requirements.

Available from: SCIH

Management of equipment

DHSS, UK (1982). Health Equipment Information No. 98

Management of the clinical engineering department: How to convert a cost center into a profit center

Fennigkoh L (1987). Quest Publishing Company Inc. ISBN: 0 930844 19 X

This book looks at how to convert a (maintenance) cost center into a profit center in order to increase operational efficiency and effectiveness. It looks at the range of healthcare technology services, how to market them, price them, and control their quality. It includes a variety of forms for record-keeping.

Available from: Quest Publishing Company Inc

Medical administration for frontline doctors: A practical guide to the management of district-level hospitals in the public service or in the private sector (2nd edition)

Pearson C (1990). FSG Communications Ltd, Cambridge, UK. ISBN: 1 871188 03 2

This book provides information for doctors who combine wide clinical responsibilities with administration and support for primary health care services. It covers a wide range of topics, with country examples, including: management structures; infrastructure and maintenance; buildings, support services, and equipment; hospital supplies and stores; training; outreach programmes; and wider responsibilities in the district and above. It includes advice on many safety topics such as cleaning procedures, linen handling, earthing, lightning protection, and fire prevention.

Available from: TALC

Medical equipment management in hospitals

American Hospital Association (1982)

This book contains scheduled preventive maintenance procedures and tables of estimated annual maintenance costs for labour and parts for a large number (over 200) of the medical equipment items found in a typical modern hospital (in the USA). The book also contains informative sections on determining productivity, how to make use of the tables to set up your own maintenance program, calculations of the feasibility of an in-house maintenance system, evaluation checklists which include financial and performance considerations for a biomedical maintenance programme, and a manufacturer's service contact.

Available from: AHA

Physical assets management and maintenance in district health management

Halbwachs H (2000). GTZ document

Reflections on the economy of maintenance: Presentation at the summit conference of the African Federation for Technology in Healthcare, Harare, Zimbabwe, 1998

Riha J, Mangenot L, Halbwachs H, and G Attemené. (1998). GTZ

This paper aims to provide convenient quantitative guidelines for engineers, administrators and decision makers on the cost implications of maintenance approaches. It explores how to define an annual maintenance cost ceiling by relating maintenance cost to the expected increase in equipment lifetime. This is achieved through the use of various equations with worked examples.

Available from: GTZ

The importance of maintenance and repair in health facilities of developing economies

Halbwachs H (1999). GTZ

This paper describes, with country examples, the consequences of a lack of maintenance and repair, and how the introduction of planned preventive maintenance can benefit the health service by providing a positive economic impact.

Available from: GTZ

The Madagascar experience

Halbwachs H (1992). In Berche T, *The district hospital: WHO-IMT-GTZ workshop report*, Yaounde, Cameroon.

This paper discusses the implementation and success of the initiative in Madagascar of creating a first (simplest/lowest) level of their HTM Service from general staff at facility level.

Available from: GTZ

The right equipment in working order

Bloom GH et al (1989). Reprinted from *World Health Forum*, Vol 10, No. 1, pp 3 – 27. WHO, Geneva, Switzerland

This document contains a series of papers that discuss planning and budgeting issues for healthcare technology in developing countries, including maintenance. They contain cost estimates (as a percentage of the capital stock value), financial planning implications, constraints and strategies. They also discuss the different roles of the users, donors, manufacturers, and their local representatives if procurement of equipment is to be successful, the need for training, and the tasks required of a maintenance department.

Available from: WHO

The technical and financial impact of systematic maintenance and repair services within health systems of developing economies or 'How good is my maintenance service?'

Halbwachs H (1998).pp57-60 in *Proceedings of the IFHE 15th International Congress, Edinburgh, June 1998*, International Federation of Hospital Engineering

This paper describes, with country examples, the consequences of a lack of maintenance and repair, and how the introduction of planned preventive maintenance and repair services can benefit the health service by providing a positive economic impact. It covers how to measure the quality of maintenance services using process, impact, and cost indicators, including savings calculations. It reports on the results of studies in three countries on the cost-effectiveness of maintenance services. It also describes a suitable national body through which donors could provide financial contributions to maintenance services.

Available from: GTZ, IFHE

See *Guide 2* for more material on planning and budgeting for maintenance and repair of equipment, and establishing an equipment inventory. See *Guide 6* on financial management for HTM Teams, including the selling of HTM services.

Repair, Planned Preventive Maintenance, and Testing Guidelines

This material covers issues in *Sections 3.2, 3.3, and 3.4* on repair techniques, maintenance schedules, skills requirements, inspections, safety testing, and advice. It is listed alphabetically by title.

A guide to power conditioning and power back-up

Huys J (1996). FAKT, Basler Mission, and HEART Consultancy

This document is an introduction to guide you through the terminology and information regarding power conditioning and power back-up. It is aimed at health workers facing problems with ensuring power quality for any electrical equipment, and ensuring power is available when you need it. It deals with the problems which can occur in the mains supply, and an explanation about the main measures which can be taken for power conditioning and power back-up (including advice on suppressing electro-magnetic interferences and radio frequency interference, and advice on different types of uninterruptible power supplies). It is meant for anybody involved in the decision-making process for the procurement, installation, and use of such equipment.

Available from: FAKT

Anaesthetic equipment: Physical principles and maintenance (2nd Edition)

Ward C (1985). Baillière Tindall. ISBN: 0 7020 1008 1

This book provides a comprehensive and practical coverage of the wide range of equipment used in anaesthetic practice. It allows the reader to understand the mode of operation and maintenance of equipment, and how to cope with common causes of mechanical failure. Suitable for trainee and established anaesthetists, intensive care specialists, anaesthetic nurses, and theatre and maintenance technicians.

Available from: book suppliers

Blood pressure measuring equipment: Principles, use, maintenance, repair

Huys J (1992). TOOL, Amsterdam. ISBN: 90 70857 26 X

This book is for medical technicians in rural hospital and clinics. It covers the principles of common BP equipment, how to use BP measuring equipment, advice about its use, and instructions for maintenance and repair.

Available from: Medical and Health Library, free at <http://media.payson.tulane.edu:8086/cgi-bin/gw?e=t1c11copyrigh-mhl-1-T.1.B.21.1-500-50-00f&q=&l=e&g=00>

Care and safe use of hospital equipment

Skeet M and Fear M. (1995). VSO. ISBN: 0 9509050 5 4

This book provides practical advice for health service staff about proper management of the type of equipment found in district hospitals or health centres. It includes guidelines on preventive maintenance and servicing, simple user instructions, checklists for correct and safe use of equipment, and basic technical information for training of first-line maintenance staff. The information is easily accessible to those without a technical background. It includes advice on many topics relating to safety and testing such as checking power supplies, gas cylinders, disinfection and sterilization, as well as a basic tool list.

Available from: TALC, VSO

De Montfort medical waste incinerators

Picken DJ (2005). De Montfort University, Leicester, UK

This website provides information on De Montfort University incinerators designed by Prof. DJ Picken. It contains copies of drawings and instructions for the building, operation and maintenance of various incinerator models. The range of DMU incinerators has been developed for use by rural PHC facilities, and designed to be constructed on site using local materials. There may be a small charge to cover the cost of printing and postage of the plans.

Available from: www.mw-incinerator.info/en/101_welcome.html

District health facilities: Guidelines for development and operation

WHO Regional Publications: Western Pacific Series No 22 (1998). ISBN: 92 9061 121 9

This revised and expanded book presents detailed, richly illustrated guidelines for the planning and design of district hospitals including the efficient utilization of space and easy movement of people, equipment, and supplies. It also provides extensive information on the selection and maintenance of medical and laboratory equipment, including PPM schedules. Additional material covers sanitation and waste management, workshop layout requirements, and test instruments.

Available from: WHO

District laboratory practice in tropical countries (part 1)

Cheesbrough M (1998). Tropical Health Technology. ISBN:0 9507434 4 5

A valuable resource aimed at those responsible for the organization and management of district laboratory services but can also be adapted for use by health centres. Covers selection and procurement of laboratory equipment and supplies, as well as their use, care, and maintenance. It covers parasitological tests, clinical tests and training of personnel, as well as all types of safety issues for laboratories.

Available from: TALC, THT

District laboratory practice in tropical countries (part 2)

Cheesbrough M (2000) Tropical Health Technology. ISBN:0 9507434 5 3

Covers microbiological, haematological and blood transfusion techniques required at district level.

Available from: TALC, THT

Electricity at work (training video)

RS Components Ltd.(1990). Code 446-2238 (catalogue page 1-201 Sept 2003)

This video examines electricity at work regulations. It includes sections on the need for regulations, the dangers of electricity, safe construction and maintenance of electrical systems, strength and capability of electrical equipment, equipment exposed to adverse conditions, prevention of danger, earthing and protective devices, electrical continuity, joints and sockets, excess current protection, isolation of equipment, live working, access for work, and suitable personnel and training.

Available from: RS Components Ltd

Emergency Care Research Institute (ECRI, USA) products

This organization produces a variety of products on healthcare technology. They are available as hard copy and as software regularly renewed by subscription, with special rates for developing countries. The data is comprehensive and primarily written for the US audience, and the software is sophisticated. The products cover various issues, such as:

- ◆ **Inspection and preventive maintenance system** (helps you plan, execute, and document your inspection and preventive maintenance activities, and contains inspection and PPM schedules)
- ◆ **HECS 4 for Windows** (software which manages a range of things such as inventories, work orders, maintenance schedules, parts)
- ◆ **Health devices alerts database** (international database of medical hazards, problems, and recalls of equipment)
- ◆ **Healthcare product comparison system**
- ◆ **Health devices source book** (a directory of manufacturers and distributors for the US market, their contact details, products, and typical price ranges)

Available from: ECRI

Engineering and maintenance services in developing countries

Mehta JC (1983). In *Approaches to planning and design of healthcare facilities in developing areas, Vol 4*, Kleczkowski BM et al (eds). WHO Offset publication No 72. ISBN: 924 170072 6

Essential equipment for district health facilities in developing countries

Halbwachs H, and A Issakov (eds.) (1994). GTZ, Eschborn, Germany

This book describes the types of equipment required at different levels within the district health services – at health post level (sub-health centre without beds), at health centre or small district hospital level (with 1–75 beds), and at district or provincial hospital level (with 76–250 beds). It also provides tool lists for these different levels of health facility, and guidance on the maintenance skill levels required for each equipment type.

Available from: GTZ, WHO

How to look after a refrigerator

Elford J, (1992). Healthlink (formerly AHRTAG). ISBN: 0 907320 07 4

Provides practical guidelines for care and maintenance of a range of kerosene, gas, electric and solar refrigerators.

Available from: Healthlink Worldwide

IEE wiring regulations (16th edition)

William Ernest (amended 2004). RS Components Ltd

This is the latest edition of the IEE wiring regulations which describes how to plan and implement electrical installations safely in accordance with international wiring rules. (Guidebooks for implementing the IEE wiring regulations are also available).

Available from: RS Components Ltd

If not in use – switch off!: Guidelines and key recommendations for a sustainable and cost-effective energy supply for health facilities in remote locations

Röttjes M (1995) FAKT, Stuttgart, Germany

This practical document aims to provide a variety of courses of action that medical and administrative staff can pursue when health facilities are hit by energy problems. It covers sustainable and cost-effective energy supplies, the different energy requirements, possible energy sources, and suggestions for a hospital energy supply. It includes PPM schedules for air-cooled diesel power plants.

Available from: FAKT

Instrumentation for the operating room: A photographic manual (5th edition)

Brooks Tighe S (1999). ISBN 0323003508

Colour photographic reference manual illustrating in detail a range of instruments for major surgical procedures: endoscopic, neurosurgery, ophthalmic, orthopaedic, and oral, maxilla and facial surgery. Also includes a section describing the care and handling of instruments from cleaning to sterilization, inspection and testing.

Available from: all major internet bookshops

Maintenance and repair of laboratory, diagnostic imaging, and hospital equipment

WHO (1994). ISBN: 92 4 154463 5

A practical manual for maintenance and repair of basic laboratory and diagnostic equipment, as well as anaesthetic machines, operation room equipment, and ultrasound and X-ray generators. Intended for use in settings that do not have technicians or engineers with specialist expertise. The manual uses line drawings and numerous checklists for inspection and cleaning, good working practices, routine operation and maintenance. It is also useful as a training aid. It includes advice on many topics relating to safety and testing such as disinfection, gas cylinders, laboratory hazards, radiation hazards, and hazards from other types of equipment, as well as providing tool lists.

Available from: WHO

Maintenance strategies for public health facilities in developing countries: Report of a workshop held in March 1989 in Nairobi by GTZ

Halbwachs H, and R Korte (1990). WHO/SHS/NHP/90.2

This report presents the results of a workshop attended by 60 participants from 18 countries including project staff and counterparts from GTZ projects in various countries, representatives of various donor agencies, and resource persons. The papers included address when to introduce PPM, maintenance strategies for different types of equipment, lists of skill levels for maintenance on different types of equipment, and spare parts and stores. It also includes the different types of personnel required in maintenance services, the training they require, experiences of establishing national training courses in hospital maintenance, and ways to monitor progress with maintenance and training.

Available from: GTZ, WHO

Manual de mantenimiento preventivo planificado (MPP)

Proyecto de Mantenimiento Hospitalario (1992). GTZ/Ministry of Public Health and Social Assistance, San Salvador

This manual contains planned preventive maintenance schedules for a wide range of medical equipment and plant. It is in Spanish.

Available from: GTZ

Manual of darkroom technique

Palmer P (1985). WHO Basic Radiological System: ISBN: 92 4 154178 4

This manual is intended for use by operators working with the WHO Basic Radiological System (WHO-BRS), but the principles and methods described can be used in the processing of X-ray films taken with any type of X-ray equipment. The manual provides a step-by-step illustrated guide to darkroom technique, and outlines all the basic requirements for the storage and handling of X-ray films and processing equipment. It contains sections covering the maintenance of the processing tank (non-electric) and the cassettes and screens. This is in the form of schedules of cleaning to be undertaken daily, weekly and monthly.

Available from: WHO

Medical equipment management in hospitals

American Hospital Association (1982)

Medical supplies and equipment for primary health care: A practical resource for procurement and management.

Kaur M, and S Hall (2001). ECHO International Health Services Ltd. ISBN: 0 9541799 0 0

This book is intended for health workers and those responsible for the procurement and management of medical supplies and equipment at primary healthcare level. It covers guiding principles for selecting supplies and equipment, provides guidelines for ordering and procurement, storage and stock control, care and maintenance, and considers decontamination and safe disposal of medical waste. The manual also discusses the use of standard lists as a tool for encouraging good procurement practice and includes model lists of medical supplies and equipment required for primary health care activities in both health facilities in the community, and basic laboratory facilities.

Available from: TALC

Medicines and Healthcare Regulatory Agency (MHRA, UK) products

This agency of the UK government (formerly the Medical Device Agency) ensures medical devices and equipment meet appropriate standards of safety, quality, performance, and effectiveness, are used safely, and that they comply with relevant Directives of the European Union. The MHRA provides a variety of publications, such as:

- ◆ **Medical device alerts** (replacing former hazard notices, safety notices, device alerts, advice notices, etc.)
- ◆ **Device bulletins** (replacing former evaluation reports)
- ◆ **Device evaluations**
- ◆ **Advice on a wide variety of safety topics** (visit the website, click on contacts, then medical devices, then search under a subject area such as decontamination, or laundry for example).

Available from: MHRA

Physical asset planning and management software (PLAMAHS)

This software package holds information, and supports analysis, on: the equipment inventory, equipment models and standards, existing and planned facilities, procurement support, and maintenance support. The software holds various digital images, standard lists and templates for forms, etc., and has a security system. It has been designed especially with developing countries in mind, is available at special rates for developing countries, and HEART can assist with the set up and initial training requirements. The maintenance support section enables you to generate job-cards for each item on your inventory, to make a detailed log of repairs, user complaints, fault diagnoses, spare parts usage, and the time, source and costs of repairs, etc. PPM schedules and intervals can be held in the system, as can user instructions and technical manuals.

Available from: HEART Consultancy

Practical laboratory manual for health centres in East Africa,

Carter J and Olema O (1998). AMREF

Practical laboratory manual providing information necessary to establish, select and use laboratory tests for patient management. Also includes material on implementation of safe working practices, reporting and recording test results, keeping an inventory of supplies and equipment, ordering supplies and maintaining equipment.

Available from: AMREF

Refrigerators use, maintenance and repair series

Expanded Programme on Immunisation (EPI) (1984-1987). WHO

EPI/LOG/84/14 - 19, 21, 22, 25, 26 and EPI/TECH.HB/A - H

This series is grouped into two sub-series: i) User and 'how to look after' handbooks, and ii) Repair technicians handbooks. The user's handbooks are comprehensive illustrated guides that contain information on installation, the components, operation, schedules for daily/weekly/monthly care, fault-finding, basic maintenance procedures, and conversion to electric operation. The 'how to look after' handbooks contain task sheets for different maintenance tasks, with information on the tools and materials required, and step-by-step action required for the tasks (written as training modules). The technician's handbooks have the same format as the user material but cover much more complicated maintenance procedures. They are meant to be used in conjunction with the manufacturers' own maintenance and repair manuals.

Available from: WHO

Safety at work (training video and interactive CD)

RS Components Ltd. (1994). Codes 446-2446 and 446-2452 (catalogue page 1-196 Sept 2003)

This video/CD covers the important safety issues that every electrical apprentice needs to know. It includes sections on the range of hazards and risks of working in the electrical industry, health and safety law, portable appliance testing, keeping an eye out for hazards, using equipment properly, accessing and handling equipment, what to do in an emergency, and recognizing the signs.

Available from: RS Components Ltd

Selection of basic laboratory equipment for laboratories with limited resources

Johns ML and ME El-Nageh (2000). ISBN: 9290212454

This book provides a framework to help laboratory workers, supply officers and decision makers to choose and buy laboratory equipment and consumables. Includes information on maintenance and energy requirements for laboratory equipment, quick reference buyer's guides and equipment data specification sheets provide easy reference for equipment buyers. The framework can be adapted to guide general equipment purchasing.

Available from: WHO

Spare parts and working materials for the maintenance and repair of health care equipment: Report of workshop held in Lübeck, August 1991

Halbwachs H, and C Temple-Bird (eds) (1991). GTZ, Eschborn, Germany

This book, mainly aimed at maintenance technicians, covers the maintenance requirements for common items used at district level (anaesthesia equipment, infant incubators, X-ray equipment, suction pumps, autoclaves and laundry equipment) including advice on common parts required, and possible modifications. It also includes some information on safety testing, test instruments, workshops, and stock control of parts.

Available from: GTZ

Sterilization of medical supplies by steam, volume 1: General theory (2nd edition)

Huys J (2003). HEART Consultancy. ISBN: 90 75829 04 3

This book focuses on the most common and most safe method used for sterilization in the Central Sterile Supplies Department in healthcare institutions – sterilization by pressurised high temperature steam. Originally intended to educate technical service personnel in remote health institutions, it has grown into a textbook that can be used by anyone interested in sterilization. Contains information on operation and maintenance, steam pulsing, monitoring sterility, self-made test packs, use of thermocouple testing kits, and process profiles. Available in several languages.

Available from: HEART Consultancy

Testing to the 16th edition (training video)

RS Components Ltd.

This video describes how to test electrical installations according to the latest IEE wiring regulations (16th edition).

Available from: RS Components Ltd

Where there is no technician: A practical guide for users of medical equipment

Rommelzwaal B, and E de Villiers (eds) (2002). MOHSS, Namibia

This manual aims to cover situations where the nearest knowledgeable maintenance technician or private company is hundreds of kilometres away, and health workers must develop basic skills related to maintenance, calibration, and safe operation of equipment. In a modular style, it covers 10 pieces of medical equipment commonly found in district health facilities. The manual intends to serve both as a training manual and as a practical reference guide for individual health workers.

Available from: Ministry of Health and Social Services, Namibia

See *Guide 4* on operation and safety for information concerning the decommissioning of equipment, a fuller discussion of a wide range of safety issues including decontamination of equipment, and more training videos. See *Guide 1* for more information on understanding the skill levels required for different maintenance tasks.

Managing Work Facilities and Tools

This material covers issues in *Section 5* on workshop design, managing activities in the workshop, and requirements for tools and test instruments. It is listed alphabetically by title.

Care and safe use of hospital equipment

Skeet M and Fear M. (1995). VSO. ISBN: 0 9509050 5 4

District health facilities: Guidelines for development and operation

WHO Regional Publications: Western Pacific Series No 22 (1998). ISBN: 92 9061 121 9

Essential equipment for district health facilities in developing countries

Halbwachs H, and A Issakov (eds.) (1994). GTZ, Eschborn, Germany

Hospital engineering in developing countries

Dammann V, and H Pfeiff (eds) (1986). GTZ, Eschborn, Germany. ISBN: 3 88085 293 6

International seminar for hospital technicians/engineers: February 1998, Moshi, Tanzania

Clauss J (ed) (1998). FAKT

Maintenance and repair of laboratory, diagnostic imaging, and hospital equipment

WHO (1994). ISBN: 92 4 154463 5

Management of solid and liquid waste at small healthcare facilities in developing countries.

Jantsch F, and H Vest, (1999). GATE-Information Service, Division 44: Environmental Management, Water, Energy, Transport, GTZ, Eschborn, Germany

This book aims to raise awareness and provide advice for healthcare waste management in order to improve the overall environmental conditions at health facilities. Part one of this practical guide provides advice on healthcare waste generation and related hygiene risks, waste management and factors influencing its effectiveness at health facilities in developing countries. Part two presents a series of detailed worksheets with illustrations to provide the reader with practical solutions suitable for immediate implementation.

Available from: GTZ, GATE

Safe management of wastes from health-care activities

Pruss A, Giroult E, and P Rushbrook (1999). ISBN: 9241545259

A comprehensive and practical guide covering all aspects of the management of health care waste. The book defines waste categories and characteristics, describes the planning needed, collection, segregation, storage, transport, and disposal of waste. There is also chapter on training and a section on simple and safe waste management techniques for emergencies and small rural facilities. It is relevant to hospitals in developing countries and health centres.

Available from: WHO

Spare parts and working materials for the maintenance and repair of health care equipment: Report of workshop held in Lübeck, August 1991

Halbwachs H, and C Temple-Bird (eds) (1991). GTZ, Eschborn, Germany

See *Part ii* for companies that produce a range of safety testing instruments, and technical literature.

Stock Control and Stores Management

This material covers issues in *Sections 4.1 and 6* on stock control, management of supplies, as well as data on the lifetime of equipment to assist with inventory control. It is listed alphabetically by title.

Estimated useful lives of depreciable hospital assets (revised 2004 edition)

American Society for Hospital Engineering (2004). American Hospital Association. ISBN: 1 55648 319 8

One of the organizations which have tried to estimate typical equipment lifetimes for healthcare technology. The AHA's extensive list reflects how equipment lasts within the United States' health care system whether it was manufactured in the US or abroad. It covers buildings, estate, fixed equipment, and individual items of movable equipment. The list was compiled after discussions with manufacturers of healthcare equipment, discussions with various hospital department managers, and analysis of actual retirement practices for actual hospital assets.

Available from: AHA

How to manage a health centre store

Battersby A (1994). Healthlink Worldwide (formerly AHRTAG).

Describes in detail the structure and organization of a store or dispensary, methods of arranging stocks, stock control, and basic dispensing.

Available from: Healthlink Worldwide

Maintenance and the life expectancy of healthcare equipment in developing economies

Hans Halbwachs, GTZ. In *Health Estate Journal* (March 2000) pp 26-31

This article comes from one of the organizations that have tried to estimate typical equipment lifetimes for healthcare technology. The GTZ estimates are for 16 types of medical equipment and plant, and tries to more closely reflect the realities in developing countries. The article describes the Delphi survey used to obtain feedback from 23 experts from 16 different country backgrounds. Rather than providing exact lifetimes, this approach provides a range for the lifetime which depends on the quality of the initial equipment and how well it has been maintained.

Available from: GTZ

Maintenance strategies for public health facilities in developing countries: Report of a workshop held in March 1989 in Nairobi by GTZ

Halbwachs H, and R Korte (1990). WHO/SHS/NHP/90.2

Medical supplies and equipment for primary health care: A practical resource for procurement and management.

Kaur M, and S Hall (2001). ECHO International Health Services Ltd. ISBN: 0 9541799 0 0

Spare parts and working materials for the maintenance and repair of health care equipment: Report of workshop held in Lübeck, August 1991

Halbwachs H, and C Temple-Bird (eds) (1991). GTZ, Eschborn, Germany

Stock control software

Stock control of items in stores is an area where simple computer software programs can be of assistance once you have mastered a manual paper system, have a large enough store (for example, at central level), and can obtain sufficient training of staff. The following products can be viewed on the internet and should provide either a full demonstration CD of the software to study, or use of a shareware program free of charge for a set period of time:

- ◆ Website: www.easy4you.net/EN/stock.htm
Low cost stock control and invoicing package for small to medium size businesses, provided as shareware software.
- ◆ Website: www.microsoft.com/BusinessSolutions/Navision/supplychain.aspx
Navision sales and stock management software is suitable for medium to large scale businesses, and is available in various building blocks. Navision is used by several central/national medical stores in Africa, but requires a lot of training
- ◆ Website: www.requisoft.com/stock/stock.html
Requisoft Stock software controls and manages an organization's stock, and allows you to browse through your stock records. It can be used on its own or as a module of the Requisoft Procurement system.
- ◆ Website: www.artisan.co.uk/products/index.php?p=Stock
Artisan stock management and control software is comprehensive, and includes complex assembly component and works order systems.

Technician's handbook for compression refrigerators – Part D: How to keep stocks of spare parts

WHO Expanded Programme on Immunization (1984). EPI/TECH.HB/D, Document EPI/LOG/84/20 in *Refrigerators use, maintenance and repair series*, WHO, Geneva.

This booklet contains a series of case studies to help the reader learn about spare parts management. Although designed for vaccine refrigerators, it can be applied to any spare parts. It has sections covering how to choose and order spare parts, how to keep track of stocks of spare parts, how to decide who should keep the stocks, and how many parts should be kept at each level of the health service. It contains exercises and case studies for each topic.

Available from: WHO

The division for the supply of medical spare parts in the health system of Kenya

Paton J, Green B, and J Nyamu (1996). Ministry of Health, Nairobi/GTZ, Eschborn, Germany

This paper describes how a Division for the Supply of Medical Spare Parts was set up and is run in the health system of Kenya, financed through the use of a revolving fund.

Available from: GTZ

Developing Skills, Managing Change, and Monitoring Progress

This material covers issues in *Section 2.1* on managing change, *Section 7* on managing staff and developing skills, and *Section 8* on target-setting and monitoring progress. It is listed alphabetically by title.

District health care: Challenges for planning, organization and evaluation in developing countries (2nd edition)

Amonoo-Larston R, Ebrahim G, Lovel H, and J Rankeen (1996). MacMillan. ISBN: 0 333 57349 8

This book contains practical support and advice intended for those in the planning, management and evaluation of health services at district level. It covers a wide range of topics based on country experience, including: staff motivation, teamwork, developing management skills, managing change, managing conflicts, and staff development; managing finances; monitoring and evaluation; as well as district health needs, plans, organization and management.

Available from: TALC

Healthcare technology: Training skills for hospital technicians and engineers

FAKT (1999). FAKT Technical Library Data Sheet

This paper discusses the major objectives of training both on- and off-the-job. It then provides practical guidance on how to undertake on-the-job training effectively by using the PESOS procedures (prepare, explain, show, observe, supervise). It explains each step in detail. Although written for maintenance staff, its advice is just as useful for any other types of staff.

Available from: FAKT

Hospital engineering in developing countries

Dammann V, and H Pfeiff (eds)(1986). GTZ, Eschborn, Germany. ISBN: 3 88085 293 6

Hospital technology: Communication – a vital skill for successful healthcare technical service management

FAKT (1999). FAKT Technical Library Data Sheet

This paper discusses the importance of communication for both working in a team and working in an organization/network. It provides advice on how to communicate effectively, its importance, the barriers that exist, how to promote effective communication, the role of the head of department, methods to use, and related reading. Although written for maintenance staff, its advice is just as useful for any other types of staff.

Available from: FAKT

How to make and use visual aids

Harford, N and N Baird (1997). VSO. ISBN: 043592317X

This booklet describes a number of useful and practical methods for making visual aids quickly and easily, using low cost materials.

Available from: TALC, VSO

Maintenance strategies for public health facilities in developing countries: Report of a workshop held in March 1989 in Nairobi by GTZ

Halbwachs H, and R Korte (1990). WHO/SHS/NHP/90.2

Management support for primary health care: A practical guide to management for health centres and local projects

Johnstone P, and J Ranken, (1994). FSG Communications Ltd, Cambridge, UK. ISBN: 1 87118 02 4

This practical user-friendly book gives support and guidance to leaders in health centres and other local projects to help stimulate and maintain primary health care (PHC) in their surrounding communities. Aid workers, and others unfamiliar with PHC and basic management techniques may also benefit. Includes sections which will assist with staff motivation, such as teamwork and team effectiveness; managing oneself, others and tasks; and managing change, as well as sections on planning and monitoring progress.

Available from: TALC

Medical administration for frontline doctors: A practical guide to the management of district-level hospitals in the public service or in the private sector (2nd edition)

Pearson C (1990). FSG Communications Ltd, Cambridge, UK. ISBN: 1 871188 03 2

Medical equipment in Botswana: A framework for management development

Temple-Bird C L, Mhiti R, and G H Bloom (1995), WHO publication WHO/SHS/NHP/95.1

See this book's details for a description of training artisans at Trade Testing Centres and training technicians at Polytechnics

On being in charge: A guide to management in primary health care (2nd edition)

McMahon R, Barton E, and M Piot (1992). ISBN: 9241544260

This practical guide aims to improve the managerial skills of middle level health workers. The text is reinforced with practical examples, questionnaires and illustrations that help relate the information to health workers' own experiences. Topics include identifying health problems, assigning priorities to their solution, planning and implementing programmes, and evaluating results. Also serves both as a training and reference guide, covering all aspects of primary health care management including equipment and drugs.

Available from: WHO

PAD: Protocols for the appraisal of physical assets management in health services in developing economies

Halbwachs H (1996). GTZ

This document presents the PAD Method for appraising the management of physical assets in healthcare through the collection of hard information to use as baseline data. It contains standardized sets of checklists for various management areas that provide a semi-quantitative and quick method of data gathering. The results can serve as a baseline for measuring project progress over several years by describing system effects rather than single technological indicators, and are therefore suitable for assessing mid- to long-term changes.

Available from: GTZ

Physical assets management and maintenance in district health management

Halbwachs H (2000). GTZ document

Results of the international survey of clinical engineering departments

Frize M (2000). IFMBE

This paper discusses how clinical engineering departments vary globally. In terms of staffing they discuss where most departments are located, how that relates to hospital size, if the departments employ more technicians than engineers, and the ongoing training provided.

Available from: www.ifmbe-news.iee.org/ifmbe-news/may2000/survey.html

Technology in health care: GTZ concepts and experience

Halbwachs H (1997). pp70-73 in *Technologie Sante*, No.31, November 1997

This paper describes the involvement of GTZ in healthcare technology management projects around the world. It describes GTZ support for the development of training courses in healthcare technology maintenance and management in various countries. The courses in Kenya and Senegal are well established, open to students from the region (and are described in *Part ii* of this Annex). There is a course in Jordan, modular courses in El Salvador, a series of seminars in the Philippines, and new course developments in Chile and Peru – for more information contact Friedeger Stierle of the GTZ.

Available from: GTZ

The technical and financial impact of systematic maintenance and repair services within health systems of developing economies or ‘How good is my maintenance service?’

Halbwachs H (1998).pp57-60 in *Proceedings of the IFHE 15th International Congress, Edinburgh, June 1998*, International Federation of Hospital Engineering

Training health personnel to operate health-care equipment: How to plan, prepare and conduct user training – A guide for planners and implementors

Halbwachs H, and R Werlein, (1993). GTZ, Eschborn

The aim of this book is to ensure that users are in a position to operate equipment and plant without causing failure or malfunction. Part one addresses the planner/administrator developing user courses and gives information about methods, course organization, finances, etc. Part two discusses interesting issues for the implementers i.e. how to design a course, teaching methods and teaching aids, conducting a course, etc. This practical guide provides sample checklists, questionnaires, worksheets, tests, certificates, etc.

Available from: GTZ

Transfer of learning: A guide for strengthening the performance of health care workers

Intrah/PRIME II/JHPIEGO (March 2002)

This book is for health care workers involved in training and learning interventions and enables them to transfer their newly acquired knowledge and skills to their jobs, resulting in a higher level of performance and sustained improvement in the quality of services at their facilities.

Available from: free online at <http://www.prime2.org/prime2/section/70.html>

WHO Interregional meeting on manpower development and training for health care equipment management, maintenance and repair: Campinas, Brazil, November 1989

WHO (1989). WHO document WHO/SHS/NHP/90.4

This document provides a comprehensive discussion of the complexities of manpower development and training for healthcare technology maintenance and management, as well as proposed strategies. It uses reports from countries, participating institutions and organizations regarding skill development for healthcare technical services. It discusses the needs, professional development, use of an equipment survey to determine manpower requirements, certification, and job descriptions.

Available from: WHO

See *Part ii* for regional and international training institutes for maintenance personnel, and *Guide 4* for more information on training in equipment operation. See *Guide 1* for more material on staffing requirements for HTM Teams and developing a Healthcare Management Information System.

Accessing Information

These websites are sources of information concerning many aspects of health service delivery. They are locations where there is, or may be, information about healthcare technology management and maintenance and repair.

Africa online: Health website: <http://bamako.africaonline.com/afol/index.php>

Provides links to health information sites related to Africa. The links are organized into the following categories: health information, health news, events, African organizations, international organizations, schools and hospitals in Africa, projects, publications and health services

AFRO-NETS (African networks for health research and development)

website: www.afronets.org

Forum for exchanging health research information in and between East and Southern Africa.

AJOL (African journals online) website: www.inasp.org.uk/ajol

Offers free online access to tables of contents and abstracts of over 70 journals published in Africa.

Deliver website: www.deliver.jsi.com

USAID funded project focusing on supply chain logistics for health products in developing countries from estimating demand for supplies, and maintaining optimal supply levels, to proper storage guidelines

Eurasia health knowledge network (EHKN) website: www.eurasiahealth.org

Specialises in the health information needs of the Former Soviet Union (FSU) and Central and Eastern Europe (CEE). Site links to clinical practical guidelines, medical textbooks, and other educational materials, many in Russian and other regional languages

FIN: Free international newsletters: www.healthlink.org.uk

Healthlink produces this publication that lists over 130 print and electronic health-related newsletters and magazines which are available free to readers in developing countries.

GATE (German Appropriate Technology Exchange) website: www5.gtz.de/gate/

The GATE Information Service seeks to improve the technological knowledge of organizations and individuals involved in poverty alleviation projects and to develop information and knowledge management systems of organizations.

Healthcare waste website: www.healthcarewaste.org

WHO site for health care waste management

Health exchange website: www.healthcomms.org

Explores issues, ideas and practical approaches to health improvement in developing countries and provides a forum for health workers and others to share viewpoints and experiences in this area.

HealthNet news website: www.healthnet.org/medpub

Weekly newsletter distributed to health professionals in Africa, Asia and Latin America. Features current, practical, clinical and public health information.

HIF-net at WHO discussion group

Discussion list dedicated to issues of improving access to reliable health information in resource-poor settings. To join, email your name, affiliation and professional interests to: health@inasp.info

HINARI (Health inter-network access to research initiative) website: www.healthinternetwork.net

WHO initiative offering free/discounted access to journals from six leading publishers.

HNP flash website: www.worldbank.org/hnpflash

A free monthly electronic newsletter dedicated to sharing knowledge regarding the latest technical developments in the fields of health, nutrition, population, and reproductive health.

ID21 health website: www.id21.org/health

An internet based development research reporting service for health policy makers and development practitioners on global health issues. Latest research summaries are provided on a searchable website, by email and in a quarterly publication.

IEC website: www.iec.ch

International Electrotechnical Committee, which sets standards for the safe manufacture of electrical healthcare technology. There is a wide range of specific standards for testing medical electrical equipment, falling under the standard numbers IEC 60101–1, 2, and 3.

IEE healthcare technologies professional network website: www.iee.org/pn/healthtech

The Institution of Electrical Engineers of the UK provides internet sites for a wide variety of engineering professions, with the aim of enabling people to communicate with their peers around the world and access the latest global industry news and key information sources. One of their professional networks focuses on healthcare technologies. It has also hosted a series of seminars on **Appropriate medical technology for developing countries**, and their reports can be obtained from the IEE.

INFRATECH discussion group

WHO forum for global exchange of information on infrastructure and health care technology issues. To subscribe send an email to LISTSERV@LISTSERV.PAHO.ORG enter in text: subscribe infratech 'your full name'.

International health exchange website: www.ihe.org.uk

Provides training, information and advice to health workers in emergency aid and development situations. This site also provides information about jobs and health development issues.

KAR (Knowledge and research programme on disability and healthcare technology) website:

www.kar-dht.org, and for the latest projects being funded use website: www.disabilitykar.net/

This is the Knowledge and Research Programme on disability and healthcare technology of the UK governments's Department for International Development (DFID). It supports a range of projects on development and use of appropriate disability and healthcare technologies in developing countries.

The website also provides links to:

- ◆ **Disability and healthcare technology newsletter** produced every six months describing the progress and findings of the projects funded;
- ◆ **KaR global database** on healthcare technology publications, organizations, manufacturers, training institutions, etc.

Programme for appropriate technology in health (PATH) website: www.path.org

PATH identifies, develops and applies appropriate technologies to public health problems in developing countries. It produces the newsletter, **Outlook**, see:

www.path.org/resources/pub_outlook.htm

Public health care laboratory website: www.phclab.com

Global forum of information exchange and resource centre for laboratory personnel and those concerned with PHC laboratory services in developing countries.

TechNet (Technical network for strengthening immunisation services) website:

www.technet21.org

Forum focusing on improving management and operational logistics for health service delivery in developing countries, in particular, immunisation services.

The manager's electronic resource center website: <http://erc.msh.org>

The ERC website is an electronic information resource and communication service for health managers, containing more than 150 ready-to-use management tools in various languages. A key feature is:

- ◆ **The health manager's toolkit**, includes spreadsheet templates, forms for gathering and analyzing data, checklists, guidelines for improving organizational performance, and self-assessment tools that allow managers to evaluate their organizations. Tools cover areas such as strategic planning, developing information systems, cost and revenue analysis, and sustainability.

WHO: Health technology and pharmaceuticals website: www.who.int/technology

This WHO site provides information on pharmaceutical and health technology developments with a particular focus on developing countries. It includes links to blood transfusion safety and clinical technology, essential drugs, medicines, vaccines and biologicals.

WHO: Management of health services (MAKER) website: www.who.int/management

This WHO site provides information, publications, and country experiences on all types of management issues for health services, such as facility management, resource management, and district management.

ii. Organizations, Sources of Publications in Part i, Resource and Information Centres, and Training Institutes

For the following institutions we have included the name, address, contact details, a brief description of the various services they offer, and additional contact details for further relevant activities.

AFTH (African Federation of Technology in Healthcare)

PO Box 19070, Tyberg 7505, South Africa

Email contacts: ykwankam@cht.uninet.cm and pheimann@mweb.co.za

For information use website: <http://ifmbe-news.iee.org/ifmbe-news/may1998/mrc.html>, and look up the South African Medical Research Council (SA MRC).

Amazon Bookshop

PO Box 81226, Seattle, Washington 98108-1226, USA

Website: www.amazon.com or www.amazon.co.uk

Internet bookshop

AIME (Association of Institutions concerned with Medical Engineering)

Website: www.aime.org.uk

American College of Clinical Engineering (ACCE)

5200 Butler Pike, Plymouth Meeting, Pennsylvania PA 19462, USA

Tel: 1 610 825 6067, website: www.accenet.org

The ACCE is an organization of clinical engineers experienced in the management and support of medical devices and technology. The purpose of the ACCE is to establish a standard of competence and to promote excellence in the practice of clinical engineering in the United States and around the world. Many ACCE members are based in overseas facilities or have broad international experience. Their International Committee is able to offer training and consultation worldwide (write to the Chairperson of the International Committee at ACCE or email: icchair@accenet.org).

American Hospital Association

Clinical Engineering Section, 840 North Lake Shore Drive, Chicago, Illinois 60611, USA

Website: <http://aharc.library.net/>

Their documents are published by HealthForum, use website: www.ahaonlinestore.com

AMREF International (African Medical and Research Foundation)

Resource Centre, AMREF Headquarters, Langata Road, PO Box 00506 – 27691, Nairobi, Kenya

Tel: 254 2 501301/2/3, fax: 254 2 609518, email: amref.info@amref.org, website: www.amref.org

Publishes practical books, journals and other literature for health workers, and provides advice on primary health care. Runs training courses and seminars.

BOND (British Overseas NGO's for Development)

Website: www.bond.org.uk

A network of more than 260 UK based voluntary organisations working in international development and development education. BOND works to promote the exchange of experience, ideas and information by acting as a broker for a variety of relationships and by collating and distributing information.

DFID (Department for international development)

Website: www.dfid.gov.uk

UK government's department for international development assistance.

ECHO International Health Services Ltd

ECHO International Health Services is no longer trading as it used to. Its services can be accessed as follows:

- i. the charitable foundation can be contacted at:
ECHO, Ullswater Crescent, Coulsdon, Surrey CR5 2HR, UK
Tel: 44 208 6602220, fax: 44 208 6680751, website: www.echohealth.org.uk/intro2.html
- ii. the trading branch of the business (wholesale providers of medical supplies and equipment) is now: Durbin PLC, 180 Northholt Road, South Harrow, Middlesex, HA2 0LT, UK
Tel: 44 208 8696500, fax: 44 208 8696565, email: cataloguesales@durbin.co.uk,
website: www.durbin.co.uk
- iii. ECHO publications are still available from TALC (see below).

ECRI (Emergency Care Research Institute)

5200 Butler Pike, Plymouth Meeting, Pennsylvania 19462-1298, USA

Tel: 1 610 825 6000 ext 5368, fax: 1 610 834 1275, website: www.ecri.org

Offers guidance and advice on health care technology, planning, procurement and management; and health technology assessment and assistance.

Elsevier Health Science

Elsevier Books Customer Services, Linacre House, Jordan Hill, Oxford, OX2 8DP, UK

Tel: 44 1865 474110, fax: 44 1865 474111, email: eurobkinf@elsevier.com,

website: www.us.elsevierhealth.com

Books published by WB Saunders, Mosby, Churchill Livingstone, and Butterworth-Heinemann are now all members of the Elsevier Science, Health Sciences Division.

European Union (EU)

http://europa.eu.int/comm/development/index_en.htm

EU site for international development and aid.

FAKT (Consultancy for Management, Training, and Technologies)

Gansheidestrasse 43, D-70184 Stuttgart, Germany

Tel: 49 711 21095/0, fax: 49 711 21095/55, email: fakt@fakt-consult.de, website: www.fakt-consult.de

Non-profit consultancy firm, that provides information on appropriate hospital and medical equipment and training in healthcare technologies. FAKT is not a supply organisation.

Fluke Biomedical Inc

5200 Convair Drive, Carson City, Nevada 89706, USA

Tel: 1 775 883 3400, fax: 1 775 883 9541, website: www.FlukeBiomedical.com

This company sells the 601 Pro Series_{XL} International Safety Analyzer for electrical safety testing in accordance with IEC 60601-1 for hospital and laboratory electromedical equipment. It produces NIBP simulators, a pulse oximeter simulator, patient simulators, an ultrasound wattmeter, a thermo-hygrometer, and performance analysers for defibrillators, electrosurgery, external pacemakers, gas flow analysers, incubators, IV pumps, and pressure meters. It also produces other test and calibration instruments for other engineering branches (such as electrical, electronic, heating and ventilation, air-conditioning).

Global Directory of Health Information Resource Centres.

Health Information for Development (HID) Project, PO Box 40, Petersfield, Hants, GU32 2YH, UK

Tel: 44 1730 301297, fax: 44 1730 265398, email: iwsp@payson.tulane.edu,

website: www.iwsp.org/directory.htm

This is a directory of health information resource centres that is arranged alphabetically by country. Between January 2000 and May 2001, Health Information for Development (HID) compiled a Global Directory of Health Information Resource Centres (HIRCs). This is available from their website. The Directory is updated on an ongoing basis.

GTZ (Deutsche Gesellschaft für Technische Zusammenarbeit – German government technical aid agency)

Division of Health and Education, PO Box 5180, D-6236, Eschborn, Germany

Tel: 49 6196 791265, fax: 49 6196 797104, email: Friedeger.Stierle@gtz.de

Website: <http://www.gtz.de/de/4030.htm>

Friedeger Stierle is the contact for the GTZ's healthcare technology management programme, and any articles or documents on HTM.

Healthlink Worldwide

Cityside, 40 Adler Street, London, E1 1EE, UK

Tel: 44 20 7539 1570, fax: 44 20 7539 1580, email: info@healthlink.org.uk,

website: www.healthlink.org.uk

Publishes a range of free and low-cost newsletters, resource lists, briefing papers and manuals about health and disability.

HEART Consultancy

Quadenoord 2, 6871 NG Renkum, The Netherlands

Tel: 31 317 450468, fax: 31 317 450469, email: jh@heartware.nl, website: www.heartware.nl

Consultancy firm working in all aspects of healthcare technology management in developing countries. It also produces and supplies the PLAMAHS software package for managing the inventory, model lists, maintenance, and procurement needs for your healthcare technology stock. HEART also undertakes research and training, and produces publications on many aspects of sterilization for developing countries. It has developed a basic testkit for performance testing of sterilizers, and can identify suppliers that still manufacture basic sterilizers (manually operated/fuel heated).

HMSO (Her Majesty's Stationery Office)

Website: www.hmso.gov.uk

Publishers of material produced by departments of the UK government.

Humanitarian Information for All

c/o Human Info NGO vzw and Humanity CD Ltd, Oosterveldlaan 196, B-2610 Antwerp, Belgium

Fax: 32 3 449 75 74, email: humanity@humaninfo.org, website: www.humaninfo.org

The goal of this organization is to disseminate health care information free-of-charge in developing countries. Thus, their Medical and Health Library makes publications available on the internet. Refer to their homepage to find the large list of publications available.

Institute of Healthcare Engineering and Estate Management (IHEEM)

2 Abingdon House, Cumberland Business Centre, Northumberland Road, Portsmouth, Hants, PO5 1DS, UK

Tel: 44 23 92 823186, fax: 44 23 92 815927, email: office@iheem.org.uk, website:

www.iheem.org.uk/index.php

IHEEM is the learned society and professional body licensed by the Engineering Council for all those working in healthcare engineering, estates and facilities management in the UK. Membership is applicable to architects, builders, engineers, estate managers, surveyors, medical engineers and other related professionals. The Institute aims to advance research, education and training in healthcare engineering and estate management. They produce the **Health estate journal**.

Institute of Physics and Engineering in Medicine (IPeM)

Fairmount House, 230 Tadcaster Road, York, YO24 1ES, UK

Tel: 44 1904 610821, fax: 44 1904 612279, email: office@ipem.ac.uk, website: www.ipem.ac.uk

Professional body for personnel working in the field of physics and engineering in medicine, both for the UK and overseas affiliates. It produces a range of publications and has information on a wide variety of medical equipment areas.

Institution of Electrical Engineers (IEE)

Savoy Place, London, WC2R 0BL, UK

Tel: 44 207 240 1871, Fax: 44 207 240 7735, email: postmaster@iee.org, website: www.iee.org.uk

Largest professional engineering society in Europe with worldwide membership for those working in electronics, electrical, manufacturing and IT professions. Produces a wide range of publications, is a source of a wide range of information, and has a Healthcare Technologies Professional Network.

Copies of their publications are available from IEE Publication Sales Department, Michael Faraday House, Six Mills Way, Stevenage, Herts, SG1 2AY, UK

Tel: 44 1438 767 328, fax: 44 1438 742 792, email: sales@iee.org.uk

International Atomic Energy Agency (IAEA)

Wagramerstrasse 5, P.O. Box 100, A-1400, Vienna, Austria

Tel: 43 222 2360, fax: 43 222 230 184 website: www.iaea.org/

Offers regionally-based training courses in the field of nuclear medicine.

International Electrotechnical Commission (IEC)

IEC Central Office, 3, rue de Varembé, P.O. Box 131, CH - 1211 GENEVA 20, Switzerland

Tel: 41 22 919 02 11, fax: 41 22 919 03 00, email: info@iec.ch, website: www.iec.ch/

Sets the standards for the safe manufacture of medical equipment.

International Federation for Medical and Biological Engineering (IFMBE)

IFMBE Secretariat, Croatia

Tel: 385 1 6129 938, fax: 385 1 6129 652, email: office@ifmbe.org, website: www.ifmbe.org/

Professional body for clinical engineers and technicians. IFMBE also produces the **Medical and biological engineering and computing journal** as well as the subscription newsletters **MBEC news** and **Clinical engineering update** which discuss pertinent issues and news concerning clinical engineers and equipment from around the world. Available from: Subscription Offices, Medical and Biological Engineering and Computing, Peter Peregrinus Ltd, Station House, Nightingale Road, Hitchin, Herts, SG5 1SA, UK.

International Federation of Hospital Engineering

Website: <http://home.enter.vg/ifhe/main.html>

This body enables national engineering professional organizations to join in a world-wide federation. It encourages and facilitates exchange of information and experience in the broad field of hospital and healthcare facility design, construction, engineering, commissioning, maintenance, and estate management. It arranges an International Congress every two years at different locations, in conjunction with a healthcare trade exhibition. It publishes a newsletter.

Isopharm Sentry Ltd

The Validation Centre, Millindale, Rotherham, South Yorkshire, S66 7LE, UK

Tel: 44 1709 811460, fax: 44 1709 813535, email: sales@isopharm-sentry.com, website: www.sentry-products.co.uk

Supplier of a wide range of validation, testing, and commissioning equipment used with items such as sterilizers, washer/disinfectors, and medical gas pipelines.

JMS (Joint Medical Store)

PO Box 4501, Kampala, Uganda

Tel: 256 41 269699 or 268482, fax: 256 41 267298, email: sales.jms@imul.com

Not-for-profit mission medical store supplying pharmaceuticals, medical supplies and equipment, with a technical department to deal with maintenance issues and capital equipment. Supplies the public and non-profit health sector in Uganda, East Africa and Great Lakes region.

Medical Research Council South Africa (MRC-SA)

PO Box 19070, 7505 Tygerberg, South Africa

Tel: 27 21 9380911, fax: 27 21 9380200, email: info@mrc.ac.za, website: www.mrc.ac.za

The MRC-SA's mission is to improve the nation's health status and quality of life through relevant and excellent health research aimed at promoting equity and development. They have a WHO Collaborating Centre for Essential Technologies in Health, at website:

www.mrc.ac.za/innovation/whocollaborating.htm

Medicines and Healthcare Regulatory Agency (MHRA)

Hannibal House, Elephant and Castle, London, SE1 6TQ, UK

Tel: 44 0207 972 8000, email: devices@mhra.gsi.gov.uk, website: www.mhra.gov.uk

Offers guidance, advice, and regulations on medical device quality, safety, performance, use, and standards.

Ministry of Health, Kingdom of Cambodia

Department of Hospital Services, Ministry of Health, 151-153 Kampuchea Krom Boulevard, Phnom Penh, Kingdom of Cambodia.

Email: procure.pcu@bigpond.com.kh, website: www.moh.gov.kh

Ministry of Health and Social Services, Namibia

Dr N Forster, Under Secretary: Health and Social Welfare Policy, Private Bag 13198, Windhoek, Namibia

Email: nforrster@mhss.gov.na

PAHO (Pan American Health Organization)

Pan American Sanitary Bureau, Regional Office of the World Health Organization,

525 Twenty-third Street, N.W. Washington, D.C. 20037, USA

Tel: 1 202 974-3000, fax: 1 202 974-3663, website: www.paho.org/

The Pan American Health Organization (PAHO) is an international public health agency working to improve health and living standards of the countries of the Americas. It also serves as the Regional Office for the Americas of the World Health Organization. Antonio Hernandez is the contact for healthcare technology issues, email: 1hernana@paho.org

Quest Publishing Company Inc

1351 Titan Way, Brea, California 92621, USA

Tel: 1 714 738 6400, fax: 1 714 525 6258

Replacement Parts Industries Inc. (rpi – “The Alternate Source”)

20338 Corisco Street, Chatsworth, California 91311, USA

Tel: 1 800 221 9723, or 1 88 882 8611, fax: 1 818 882 7028, email: order@rpiparts.com,

website: rpiparts.com

This supplier acts as an alternate source of quality and competitively priced replacement parts for well-known makes of healthcare equipment. The catalogue is divided into sections according to equipment types (such as sterilizers, dental equipment, centrifuges, infant incubators, lamps/bulbs) and provides information on which parts will fit which make of machine. There are descriptions and illustrations to simplify identification. It not only covers current models, but can help you find parts for older models of equipment that you may still own. The company also offers technical assistance on repair solutions.

Rigel Medical Ltd

Bracken Hill, South West Industrial Estate, Peterlee, County Durham, SR8 2SW, UK

Tel: 44 191 587 8744/41, fax: 44 191 586 0227, email: info@rigelmedical.com,

website: www.rigelmedical.com

This company produces the Rigel 266 Plus electrical safety tester for undertaking medical safety testing in accordance with IEC 60601-1, a free guide on medical safety testing, a NIBP simulator, pulse oximeter simulator, patient simulator, defibrillator analyser, pressure vacuum meters, and ventilator tester.

RS Components Ltd.

Birchington Road, Corby, Northants, NN17 9RS, UK

Tel: 44 1536 201234, fax: 44 1536 405678, email: general@rs-components.com, website: rswww.com

Supplier of equipment, supplies, parts, and components for a wide range of engineering professions such as electrical, electronic, mechanical, heating, ventilation, air-conditioning, plumbing, welding, pneumatics, computing, automotive. Also a source of textbooks, technical data books, technical literature, and training videos for all these engineering fields.

Source (International Information Support Centre)

The Wellcome Trust Building, Institute of Child Health, 30 Guildford Street, London, WC1N 1EH, UK
Tel: 44 20 7242 9789 ext 8698, fax: 44 20 7404 2062, email: source@ich.ucl.ac.uk,
website: www.asksource.info

The Source Centre has a unique collection of over 20,000 health and disability related information resources. These include books, manuals, reports, posters, videos, and CD-Roms. Many materials are from developing countries and include both published and unpublished literature.

SpaceLabs Medical Inc

15220 N.E. 40th Street, Redmond, WA 98052, USA

Tel: 1 206 882 3700, website: www.spacelabs.com/

Spacelabs Medical is a leading global provider of patient monitoring and clinical information systems. Their educational service produces a Biophysical Measurement Book Series for biomedical and clinical professionals.

Swiss Centre for Development Cooperation in Technology and Management (SKAT).

Website: www.skat.ch/dc/publ/publ.htm

SKAT works internationally in the areas of water and sanitation, architecture and building, transport infrastructure, and urban development. They also publish the **SKAT newsletter**

Swiss Centre for International Health (SCIH)

Swiss Tropical Institute, Socinstrasse 57, PO Box, CH-4002 Basle, Switzerland

Tel: 41 61 284 82 79, fax: 41 61 271 86 54, email: martin.raab@unibas.ch,

website: www.sti.ch/francais/scih/scih.htm

Undertakes consultancies in healthcare technology management in developing countries and countries in transition.

TALC (Teaching Aids at Low Cost)

PO Box 49, St. Albans, Herts, AL1 5TX, UK

Tel: 44 1727 853869, fax: 44 1727 846852, email: talc@talcuk.org website: www.talcuk.org/

UK registered non-profit charity specialising in supplying affordable books, slides and teaching aids on health and community issues in developing countries, with a particular focus on materials for PHC and district levels.

Third World Network

Email: twnet@po.jaring.my, website: www.twinside.org.sg

The Third World Network is an independent non-profit international network of organizations and individuals involved in development issues. Its website offers articles and position papers on a variety of subjects related to developing countries, including trade, health, biotechnology and bio-safety.

Transaid (Transport for Life)

137 Euston Road, London, NW1 2AA, UK

Tel: 44 20 7387 8136, fax: 44 20 7287 2669, email: info@transaid.org website: www.transaid.org

A charity working in the field of international transport management. Thus unique organization works with many sectors, including health, to ensure that transport resources are efficiently and effectively used. Their aim is to develop local capacity in transport and logistics management. They produce a newsletter **Hub and spoke**, and have developed the **Transaid transport management handbook**.

Tropical Health Technology (THT)

14 Bevills Close, Doddington, March, Cambridgeshire PE15 OTT, UK

Tel: 44 1354 740825, fax: 44 1354 740013, email: thtbooks@tht.ndirect.co.uk,

website: www.tht.ndirect.co.uk

Charity concerned with supporting and improving laboratory services in the developing world. Primary focus is laboratory services, information and technology. Specializes in supply of laboratory equipment, books, bench aids, slide sets and microscopes.

Ultramedic Ltd

4F Wavertree Boulevard South, Wavertree Technology Park, Liverpool, L7 9PF, UK
 Tel: 44 151 228 0354, fax: 44 151 252 1673, email: sales@ultramedic.com,
 website: www.ultramedic.com

This company sells the 601 Pro Series_{XL} International Safety Analyzer for electrical safety testing in accordance with IEC 60601-1 for hospital and laboratory electromedical equipment. It also produces NIBP simulators, a pulse oximeter simulator, patient simulators, an ultrasound wattmeter, thermohygrometer, and performance analysers for defibrillators, electrosurgery, external pacemakers, incubators, IV pumps, pressure meters, and ventilators. It also sells medical scopemeters, isolation transformers, oxygen monitors, and digital tachometers.

Voluntary Service Overseas (VSO), and VSO Books

317 Putney Bridge Road, London, SW15 2PN, UK
 Tel: 44 20 8780 2266, email: webteam@vso.org.uk, website: www.vso.org.uk

A UK-based charity with worldwide experience of providing skilled volunteers for work overseas, including workers in the fields of medicine, hospital engineering, and associated technical services. VSO Books publishes practical books about specific areas of development, using the professional experience of volunteers.

World Bank (WB)

www.worldbank.org
 One of the world's largest sources of development assistance including health, nutrition and population projects

World Council of Churches (WCC)

PO Box 2100, 1211 Geneva, Switzerland
 Tel: 41 22 791 6111, fax: 41 22 791 0361, email: info@wcc-coe.org, website: www.wcc-coe.org
 International fellowship of churches that produces publications and newsletters. Recent publications include **Guidelines on medical equipment donations**.

World Health Organization (WHO)

20 Avenue Appia, CH-1211 Geneva 27, Switzerland
 Tel: 41 22 791 2476 or 2477, fax: 41 22 791 4857, website: www.who.int/en/
 WHO offers advice, and undertakes programmes, on all aspects of health care. Contact your regional or field office for advice on all aspects of health care and WHO materials – the addresses of the regional offices worldwide are available on the website.

- i. WHO has programmes and literature on many aspects of healthcare technology management. Andrei Issakov, Coordinator of Health Technology and Facilities Planning and Management, is the contact, and source of WHO literature on healthcare technology management that is not available as published documents, email: issakova@who.int.
- ii. WHO produces and distributes books, manuals, journals, practical guidelines and technical documents, several include aspects of healthcare technology management. The Distribution and Sales Office is the contact point for information on WHO publications, email: publications@who.ch, website: www.who.int/publications/en/. To order WHO publications use email: bookorders@who.int.
- iii. WHO has a comprehensive library and information service on international public health literature. Contact email: library@who.int. The WHO library catalogue has electronic access to more than 4000 technical documents, use website: www.who.int/library.
- iv. WHO produces many newsletters, for a list contact website: www.who.int/library/reference/information/newsletters/index.en.shtml

Ziken International Consultants Ltd

Causeway House, 46 Malling Street, Lewes, E.Sussex, BN7 2RH, UK
 Tel: 44 1273 477474, fax: 44 1273 478466, email: info@ziken.co.uk, website: www.ziken.co.uk
 A consultancy organization working worldwide in many aspects of health care development, including healthcare technology management.

Training Institutes

This section lists some of the regional and international institutions that offer a range of courses for technical staff in healthcare technology maintenance at various levels. Some of the courses also offer a training component in healthcare technology management. These institutions are known to train staff from developing countries or aim their training at students from developing countries.

American College of Clinical Engineering (ACCE)

5200 Butler Pike, Plymouth Meeting, Pennsylvania PA 19462, USA

Tel: 1 610 825 6067, website: www.accenet.org

Courses offered:

- ◆ short tailor-made advanced healthcare technology management/clinical engineering workshops run jointly by ACCE, PAHO and WHO four to five times a year in all WHO regions (contact the International Committee, email: icchair@accenet.org).

British Columbia Institute for Technology (Canada)

School of Health Sciences, 3700 Willingdon Avenue, Burnaby, British Columbia, Canada, V5G 3H2

Tel: 1 604 434 5734, email: anthony_chan@bcit.ca, website: www.bcit.ca, contact: Anthony Chan

(Program Head)

Courses offered:

- ◆ 2-year full-time diploma of technology in biomedical engineering (for high school graduates with qualifications in specific subjects)
- ◆ web-based continuing education course in medical technology management
- ◆ web-based continuing education course in medical device development and standards
- ◆ extra courses, seminars, and workshops in assorted medical technology subjects run on campus.

Campinas University (UNICAMP), Brazil

Email: calil@ceb.unicamp.br, website: www.deb.fee.unicamp.br/ec

Contact: Saide Jorge Calil, (Course Coordinator)

Course offered:

- ◆ 18-month part-time post-graduate clinical engineering specialization course.

The course is run for Portuguese-speaking students, and is aimed at those wishing to work as clinical engineers in the health sector, whether industrial, government or other hospitals.

Catalan Agency for Health Technology Assessment and Research (CAHTA)

30 Esteve Terradas, Edifici Mestral (1a planta), Recinte Sanitari Parc Pere Virgili, 08023 Barcelona, Spain

Tel: 34 93 259 42 00, fax: 34 93 259 42 01, email: direccio@aatrm.catsalut.net

Website: www.aatrm.net/html/en/dir395/index.html, contact: Dr Emília Sánchez

Courses offered:

- ◆ 4-month part-time assessment of health care services course
(website: www.uoc.edu/masters/esp/sanidad/sanidad/servicios_sanitarios.html)
- ◆ 4-month part-time information management for decision making course
(website: www.uoc.edu/masters/esp/sanidad/sanidad/habilidades_informacionales.html)

This agency also participates in two modules of the International Masters Degree in Health Technology Assessment and Management, at the University of Barcelona.

Centre National de Formation de Techniciens en Maintenance Hospitalière, (Ministry of Health, Senegal)

Diourbel BP 16, Senegal

Tel: 221 971 13 42, fax: 221 971 13 42, website: www.cnfthm.sn, contact: Mr. Saliou Dione (Director)

Courses offered:

- ◆ 3-year 'Brevet de Technicien' certificate course in hospital maintenance, which includes maintenance management
- ◆ 1-year hospital maintenance course for secondary school certificate holders
- ◆ ongoing training courses from 1 week to 5 months in electronics, medical equipment, sterilization, power generation, air conditioning, laboratory equipment, etc.

All courses are in French, can be tailored for the different qualifications of candidates (vocational training, middle certificates, professionals, etc), and are open to French-speaking students from the region.

The Diourbel Centre is a WHO Collaborating Centre for equipment/maintenance issues.

Department of Clinical Physics and Bioengineering Overseas, (West of Scotland Health Board, UK)

South Glasgow University Hospitals NHS Division, 135 Govan Road, Glasgow, G51 4TF, Scotland, UK

Tel: 44 141 201 1889/1888, fax: 44 141 201 1891, email: dporter41@tesco.net, or

dr_david_porter@hotmail.com

Website: www.show.scot.nhs.uk/sguht/professionals/dcpbo.htm, contact: Dr David Porter (Overseas Projects Manager)

Courses offered:

- ◆ tailor-made courses in healthcare technology operation, maintenance, and management for overseas students
- ◆ 3-year degree course in physics with medical technology (with Paisley University)
- ◆ Masters degree and Doctorate in medical technology
- ◆ on-the-job work experience training for staff working towards qualifications for their professional body (IPEM)

The Department also undertakes consultancies in developing countries through its Overseas Training and Support Group.

Eastwood Park Training and Conference Centre, UK

Falfield, Wotton-under-Edge, Glos, GL12 8DA, UK

Tel: 44 1454 262777, fax: 44 1454 260622, email: training@eastwoodpark.co.uk,

website: www.eastwoodpark.co.uk

Courses offered:

- ◆ a wide range of scheduled and tailor-made short courses in healthcare engineering, estates and facilities, at certificate level accredited with known bodies (such as BTEC, City and Guilds).
- ◆ specific equipment courses, such as sterilization technology courses.

Health Technology Assessment Unit (Ministry of Health, Malaysia)

Health Technology Assessment Unit, Medical Development Division, Ministry of Health, Malaysia, Level 4, Block E1, Govt. Office Complex, Precinct 1, 62250 Putrajaya, Malaysia

Tel: 60 3 8883 1228, fax: 60 3 8883 1045, email: sivalal@hotmail.com, and sivalal2001@yahoo.com

Contact: Dr S Sivalal (Head, Health Technology Assessment Unit)

Courses offered:

- ◆ annual 4-day HTA training course
- ◆ two systematic review workshops aimed mostly at physicians involved in formulating clinical practice guidelines
- ◆ HTA seminars for other health personnel like allied health professionals
- ◆ an occasional supply chain management seminar focusing on the different components of technology management
- ◆ a module on health technology management run for students of the Masters in Public Health programme at the University of Malaya.

Institut International Supérieur de Formation des Cadres de Santé (IISFCS)

Hôpitaux de Lyon-162, Avenue Lacassagne-69424, Lyon, France

Tel: 33 4 72115105, fax: 33 4 72115122, email: marie-jo.pachtem@chu-lyon.fr

Contact: Maryjo Pachtem (Technical Director)

Courses offered:

- ◆ 12-month multidisciplinary training certificate in hospital maintenance for senior technicians
- ◆ 5-month specialized training certificate in the maintenance of medical imaging for senior specialized technicians
- ◆ 5-month specialized training certificate in laboratory maintenance for senior specialized technicians

All students come from French-speaking developing countries and must have as a minimum a higher-level technical diploma. Professional experience in the field is desirable but not a prerequisite.

The Lyon Institute is a WHO Collaborating Centre for training in hospital maintenance training

Mombasa Polytechnic, Kenya

Department of Medical Engineering, Mombasa Polytechnic, PO Box 90420, Mombasa, Kenya

Tel: 254 41 492222/3/4, 490571, email: msapoly@africaonline.co.ke, msapoly@kenyaweb.com

Website: www.mombsapoly.ac.ke, contact: The Chief Principal or The Head of Department of Medical Engineering

Courses offered:

- ◆ 3-year diploma in medical engineering, with one term field attachment
- ◆ a certificate in medical engineering services
- ◆ a number of specialized courses offered occasionally on request, covering specific aspects of medical equipment or hospital facilities. They are aimed at professionals already working in the field, and last from one to four weeks.

The courses are open to English-speaking students from the region.

The Department is a WHO Collaborating Centre for training in hospital maintenance.

Tshwane University of Technology, South Africa

Department of Biomedical Sciences, Faculty of Health Sciences, Technikon Pretoria, PB X680, Pretoria 0001, South Africa

Tel: 27 12 3186267, fax: 27 12 3186262, email: dtoitd@techpta.ac.za,

Website: <http://intranet.tut.ac.za> or www.techpta.ac.za, contact: Prof. D du Toit (Head of Department)

Courses offered:

- ◆ Bachelor's degrees, Masters degrees and Doctorates in biomedical technology, clinical technology, and diagnostic radiography.

Various institutions have merged to become the Tshwane University of Technology, the Department of Biomedical Sciences is still on the Pretoria Technikon site.

Université de Technologie de Compiègne, France

BP 60319-60203, Compiègne Cedex, France

Tel: 33 3 44 234423, fax: 33 3 44 234300, website: www.utc.fr

Courses offered:

- ◆ postgraduate level courses in clinical engineering for French-speaking students.

Université Montpellier II, France

Place Eugène Bataillon, 34095 Montpellier Cedex 5, France

Tel: 33 4 67 143030, fax: 33 4 67 143031, website: www.univ-montp2.fr

Courses offered:

- ◆ postgraduate level courses in clinical engineering for French-speaking students.

University of Cape Town, South Africa

Dept. of Human Biology, UCT Faculty of Health Sciences, Anzio Road, Observatory 7925, South Africa
Tel: 27 21 406 6545, fax: 27 21 448 3291, email: poluta@cormack.uct.ac.za, website: sizanani.uct.ac.za
Contact: Mladen Poluta (Programme Convenor)

Courses offered:

- ◆ 18-month postgraduate diploma in healthcare technology management
- ◆ 12- to 24-month MSc in biomedical engineering
- ◆ 12- to 18-month MPhil programme in biomedical engineering

The courses are open to English-speaking students from the region.

The department is a participating centre in the Medical Research Council-South Africa/WHO Collaborating Centre for essential technologies in health.

Training in General

In addition to the institutions listed above, there are many others that provide training in subject areas such as biomedical engineering, clinical engineering, etc. that are aimed at home students, but overseas students can apply. These can be found in any part of the world by searching on the internet stating the type of course required and the geographical region. For example:

- ◆ for courses in the United States of America, see website: www.collegesurfing.com or www.Degree-Finder.com
- ◆ for courses in biomedical engineering in the UK and Ireland at institutions which wished to be on this website, see website: www.gradschools.com/listings/UK/bimed_eng_UK.html
- ◆ for B.Tech and degree courses in biomedical engineering in India, see this report from The Hindu newspaper website: www.hindu.com/edu/2005/04/19/stories/2005041900290300.htm.

ANNEX 3: SKILL LEVELS FOR DIFFERENT MAINTENANCE TASKS

You will need to determine the specific maintenance and repair requirements of your in-house HTM Team. This is determined by the different technical levels of skill required, which depend on the type of maintenance problems and the types of healthcare technology you use, as shown in Box 40.

BOX 40: Skill Levels Required According to Maintenance Needs

Level of complexity	Type of technology and maintenance task	Service provision by:
Skill level 1	Basic maintenance tasks on basic equipment – for example, oiling castors on beds. Basic maintenance tasks on more complex technologies – for example, cleaning and replacing the air filter of an infant incubator.	Equipment users, with training – clinical, medical and paramedical staff, general health personnel, plant operators, attendants, patients, in-house maintainers, patient caretakers, administrative staff, drivers. Local artisans – private sector artisans and in-house artisans.
Skill level 2	Medium-level maintenance tasks on basic equipment – for example, adjusting scale balances. Medium-level maintenance tasks on more complex technologies – for example, checking the integrity of electrical grounding.	In-house craftspeople and technicians – maintainers with polyvalent skills (in other words, skills that cover a range of engineering disciplines).
Skill level 3	High-level maintenance tasks on medium-level technologies – for example, overhauling the hydraulic system of an operating table. High-level maintenance tasks on more complex technologies – for example, fault-finding problems with diathermy machines.	Maintenance specialists – technologists, engineers.
Skill level 4	Sophisticated-level maintenance tasks on high-level technologies – for example, calibrating flowmeters on anaesthetic machines. Sophisticated-level maintenance tasks on sophisticated technologies – for example, repairing CT scanners.	Specialized firms – manufacturers' representatives, independent private companies.

However, not all of the skills presented in *Box 40* need to be permanently present in your health facility, and some may be required only rarely. *Figure 26* provides a visual way of imagining how much of the maintenance work is undertaken at each skill level, across your whole health service (not necessarily at each health facility).

Figure 26: Division of Maintenance Work by Skill Level in the Health Service

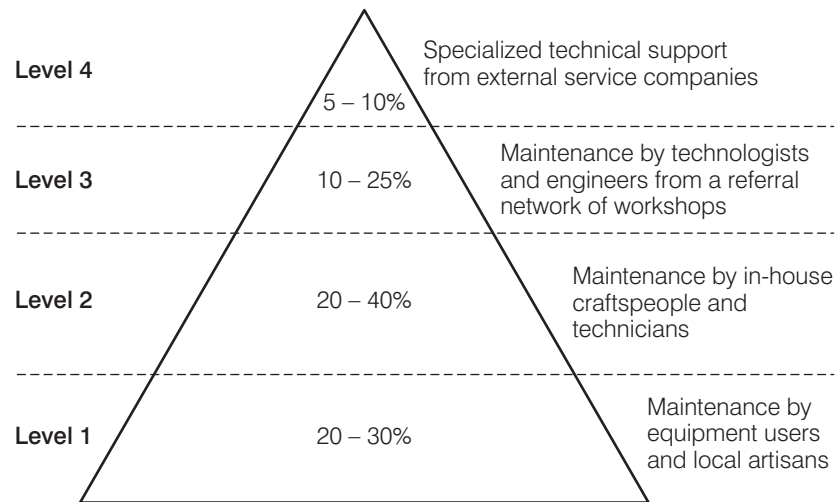

Adapted from: Raab M, 1999, 'Maintenance strategies', Swiss Center for International Health, Basel, Switzerland, August 1999

For more information on how to calculate the skill and workload requirements for different types of health facility, see *Guide 1* on organizing an HTM system.

ANNEX 4: THE ROLE OF EQUIPMENT USERS IN MAINTENANCE

Care and Cleaning

The most basic form of maintenance that equipment users are responsible for is the regular care and cleaning of equipment. *Box 41* provides some examples of general strategies for users when caring for and cleaning equipment.

BOX 41: Common Care and Cleaning Strategies

- ◆ Keep all items clean and dry.
- ◆ Dust equipment (such as large free-standing items) regularly.
- ◆ Where applicable, replace the dust cover at the end of the shift; if there is no dust cover, make one.
- ◆ Keep equipment, such as laundry and kitchen equipment, clear of debris such as fluff, food, threads, grease, paper waste, etc.
- ◆ Switch-off and unplug items when they are not in use, **except** for items which have a battery back-up that must keep charging (such as defibrillators), or items which need a continuous supply (refrigerators, etc.).
- ◆ When cleaning, never flood the machine with fluid or a dripping wet cloth, use a damp cloth instead.
- ◆ Clean with the appropriate chemicals, solutions and materials at the end of the shift (equipment which comes into contact with patients, uses gels, etc.). The operator manual will contain guidance on the correct chemicals to use (see *Guide 4* on operation and safety).
- ◆ Disinfect equipment such as theatre equipment after each patient. Check the operator manual for guidance on the correct disinfection method (see *Guide 4*).
- ◆ Unknot tangled leads on ECG recorders, interferential units and the like.
- ◆ When moving equipment, unplug the power cord and wind it up starting from the machine end and working to the plug, in order to avoid twists.
- ◆ Wipe accessories such as ultrasound probes and reusable electrodes clean of lubricants and fluids.
- ◆ Store accessories carefully in appropriate places (pouches, holders, etc.).
- ◆ Store small items properly when they are not in use (keep diagnostic sets in their cases, for example).
- ◆ Remove batteries when battery-operated items are not in use in order to avoid corrosion (for example, ophthalmoscopes, doppler heart rate detectors).
- ◆ Take apart items that disassemble easily and clean internal parts (for example, unscrew stethoscope earpieces and remove aural wax, detach and clean the valves on ambu bag resuscitators).
- ◆ Store lenses, such as microscope objectives and eye pieces, with a desiccator such as silica gel sachets to prevent fungal growths.
- ◆ In the case of items that need water to operate, such as water stills and autoclaves, always check that water is present before switching the item on.
- ◆ Check that oxygen bottles are free from oil and grease (which can cause explosions).

General User PPM Tasks

In addition, equipment users can undertake the sorts of planned preventive maintenance (PPM) tasks that do not require the intervention of technical staff from the HTM Service, and for which they have been trained. *Box 42* provides examples.

BOX 42: Typical Examples of the User's Role in the PPM of Equipment

- ◆ Calibrate equipment to ensure it is operating within its required parameters (scales, photometer, etc.).
- ◆ Check and tighten loose screws (bed frames, etc.).
- ◆ Change filters after their recommended duration of use (suction pumps, infant incubators, etc.).
- ◆ Check for correct oil levels (air compressor engine oil, washing machine gear oil etc.), or water levels (bench-top autoclave reservoirs, infant incubator humidifiers, etc.), and refill as necessary.
- ◆ Oil or grease moveable parts (trolley wheels, microtome slides, etc.).
- ◆ Replace lost, worn out, cracked, or broken parts (stethoscope earpieces and diaphragms, rubber seals in pressure-cooker-type steam sterilizers, etc.).
- ◆ Sharpen blades (scissors, microtome knives, etc.).
- ◆ Check and replace chart recorder paper (blood bank refrigerators, ECG recorders etc.).
- ◆ Ensure that programmable or manual settings are returned to normal after the work of the previous day or shift (diathermy machines, monitors, etc.).
- ◆ Inspect for wear and damage, and either inform technical staff (in the case of cracks in bedframes, poor condition of mains cable and connectors, etc.) or replace the faulty article if it is a standard stock item (chipped suction bottles, torn screen material, etc.).
- ◆ Replace batteries and bulbs when they reach the end of their lives.
- ◆ Check battery charging level lights, and warning lights and respond as necessary (defibrillator, patient monitor, etc.).
- ◆ Check that dials, gauges, indicator lights, etc. are working properly.
- ◆ Go through the machine's automatic functional check programme (infant warmers etc.)
- ◆ Descale elements (water distillers, boilers, etc.).
- ◆ Perform Bowie & Dick tests (for autoclaves) according to the recommended scheme.

Examples of Specific User PPM Tasks for Particular Equipment

Box 8 (Section 3.3) provides an example of PPM instructions for maintenance staff to carry out on infant incubators. The instructions to maintenance staff assume that the users of the infant incubators are already undertaking the user PPM tasks shown in *Box 43*.

BOX 43: Example of User PPM Instructions for Infant Incubators

Daily

- ◆ Clean incubator canopy inside and out.
- ◆ Check access port doors are working satisfactorily and do not spring open.
- ◆ Check electrical mains lead and plug for wear and tear.
- ◆ Check water filler point is in good condition and clean.
- ◆ Check cradle tilt is correctly positioned and can be easily adjusted.
- ◆ Drain off water tray and clean it. Run equipment for 30 minutes to dry tray. Refill tray with sterile distilled water just before reuse. If water for humidity is not used, simply clean water tray.
- ◆ If oxygen is used, check connection and concentration levels.
- ◆ Carry out functional tests.

The example of maintainer PPM instructions for electrode boilers in *Box 9 (Section 3.3)* assumes that the equipment users are already undertaking the user PPM tasks shown in *Box 44*.

BOX 44: Example of User PPM Instructions for Electrode Boilers

Daily

- ◆ Before starting the boiler:
 - check the blowdown valve is open
 - check the inset valve is open
 - check the water level in the 'hot-well' is okay
 - check that the boiler feed pump is operating correctly.
- ◆ Check all gauges (hourly).
- ◆ Check if the condensate is returning.
- ◆ Check for leaks.
- ◆ Check for equal loading on phases.
- ◆ Check solenoid valve operation.
- ◆ Test the water hardness and conductivity.

ANNEX 5: GENERAL MAINTENANCE REGISTER

A General Maintenance Register provides a basic method of recording work requests, but it is difficult to use for the purpose of monitoring the completion of jobs, or for monitoring the progress of a particular job. However, such a register may be the only type of record-keeping that your staff can manage initially.

Figure 27 provides a sample layout for the double-page spread within an A4 book that can act as the General Maintenance Register, with an example included of the type of entries.

Figure 27: Sample General Maintenance Register Layout

Date	Equipment	Serial no.	Dept.	What is wrong	What was done/ is needed	Maintainer's signature and date	Signature and date when job completed
9/10/02	Infra-red lamp	123567	Physio	Lamp not lighting	Broken wire soldered. Bulb on order.	Mushota 10/10/02	

ANNEX 6: TOOLS LISTS

The tool lists provided here are examples of the type of needs required by different sorts of maintenance staff. However, HTM Teams will need to personalize them to their own requirements. Resource materials that provide different tool lists are described in *Annex 2*.



- Tip** • The lists here describe metric tools. If you have older equipment to maintain, you will also need the imperial version of:
- allen keys
 - feeler gauges
 - spanners (open)
 - spanners (ring)
 - spanners (socket)
 - wrenches (box).

1. Tool List for an Equipment User

Description	Size/Type	Quantity
Pliers (longnose)	125mm insulated	1
Screwdrivers (flat and cross-head)	mix, several sizes	1 set
Spanner (adjustable)	250mm	1
Tool box (lockable)	steel, small	1
Toothbrush		1

2. Tool List for a Single Polyvalent Technician

Description	Size/Type	Quantity
Allen keys	2 – 10mm	1 set
Brush (paint, flat)	25mm	3
Brush (paint, round)	2cm diameter	3
Chisel (bolster)	100mm	1
Chisel (cold)	12mm, 25mm	1 set
Drill bits (masonry)	3 – 15mm	1 set
Drill bits (steel)	1mm – 13mm	1 set
Drill (hammer, electric)		1
Drill (hand)		1
File (flat)	250mm, with handle	1
File (round)	250mm, with handle	1
Funnel (plastic)	100mm diameter	2
Grease gun		1
Hack saw blades	senior and junior	1 set
Hack saws	senior and junior	1 set

Continued opposite

2. Tool List for a Single Polyvalent Technician (continued)

Description	Size/Type	Quantity
Hammer (claw)	450gm	1
Hammer (club)	1 kg	1
Hammer (plastic/leather twin face)	280mm	1
Knife blades		1 set
Knife (retractable)		1
Nails (assorted)		1 set
Oil can		1
Plier cutters	125mm insulated	1
Pliers (circlip)	for BP meter zeroing	1
Pliers (combination)	125mm insulated	1
Pliers (longnose)	125mm insulated	1
Pliers (slip, joint)	24mm, 2 position	1
Pliers (water pump)	25mm, 5 position	1
Saw (wood)		1
Screwdriver (mains tester)	neon indicator	1
Screwdrivers (cross-head)	No. 0 – No. 4 insulated	1 set
Screwdrivers (flat)	3.2 – 12mm insulated	1 set
Screwdrivers (precision/jewellers)	flat and cross-head	1 set
Screws (assorted)		1 set
Spanner (adjustable)	150mm, 250mm	1 set
Spanners (open)	9mm – 22mm	1 set
Spanners (ring)	9mm – 22mm	1 set
Spirit level		1
Steel square		1
Tape measure (retractable)	3 metres, steel	1
Tool box (lockable)	steel	1
Torch and batteries	handheld	1
Vice (engineer's)	bench mounted	1
Wire brush	brass	1
Wire stripper/cutter	adjustable gauge	1
Workbench	portable	1
Wrench (mole grip)	250mm	1
Wrench (pipe/stilson)	355mm	1

Continued overleaf

2. Tool List for a Single Polyvalent Technician (continued)

Depending on how much of a general all-round handyman you want this polyvalent technician to be, and the resources that already exist at the health facility, he or she may also need:

Description	Size/Type	Quantity
Crowbar		1
Extension cable	25m	1
Float (plasterer's)		1
Hawk (plasterer's)		1
Ladder, step	2m	1
Panga/grass slasher		1
Pickaxe		1
Shovel		1
Spade		1
Trowel (brick)		1
Wheelbarrow		1

3. Tool List for Specific Technicians and Artisans

These lists contain both hand tools and bench tools by type of trade (engineering/craft skill). The lists you need will depend on the type of maintenance staff you have, with the more specialist trades employed at larger workshops. Whether you need the full contents of each list will depend on your staff's skills, and the work they plan to do.

Any assistant to these technicians/artisans can use the tool list described for the polyvalent technician (*List 2*). In addition, *List 4* details general tools for the workshop that any of these trades can use and share.

3a. Electrical and electronics/biomedical technician or artisan

Description	Size/Type	Quantity per staff member
Tool list for polyvalent technician	<i>List 2</i> described above	1 kit
Cable crimping tool	plus assorted lugs	1 set
De-soldering gun	spring loaded	1
Feeler gauges	0.05mm – 1mm	1 set
Files (needle)	6 assorted precision, with handle	1 set
Hot air gun	electric	1
Mirror, inspection	angle ended	1
Probing magnet		1
Punch (centre)	automatic, adjustable	1
Punches (pin)	2mm, 4mm, 6mm, 8mm	1 set
Reamer (de-burrer)	with 'T' handle	1
Solder dispenser		1

Continued opposite

3a. Electrical and electronics/biomedical technician or artisan (continued)

Description	Size/Type	Quantity per staff member
Soldering iron	25W, with stand and sponge	1 set
Spanners (open)	miniature, 4 – 8mm	1 set
Spanners (ring)	miniature, 4 – 8 mm	1 set
Spanners (socket)	6mm – 22mm, with ratchet	1 set
Tape, insulation	PVC, red, white and black	1 set
Tips for soldering iron	flat, micropoint, and chisel	1 set
Toothbrush		1
Tweezers	small, stainless steel	1
Wrench (box)	8mm – 19mm, with tommy bars	1 set

Note: These maintenance staff also require test instruments (such as a multimeter, a mains socket wiring tester) – for details of these requirements see *Box 12*

3b. Mechanical technician or artisan

Description	Size/Type	Quantity
Tool list for polyvalent technician	<i>List 2</i> described above	1 kit
Calipers (spring)	inside, outside	1 set
Feeler gauges	0.05mm – 1mm	1 set
Files (square)	250mm and 350mm, with handle	1 set
Hammer (ball pien)	225g, 450g	1 set
Hammer (sledge)	3kg	1
Punch, centre	automatic, adjustable	1
Punches, pin	2mm, 4mm, 6mm, 8mm	1 set
Spanner (adjustable)	375mm	1
Spanners (open)	24mm – 32mm	1 set
Spanners (ring)	24mm – 32mm	1 set
Spanners (socket)	4mm – 32mm, with ratchet	1 set
Vernier caliper	300mm	1
Wire brush	steel	1

3c. Plumbing technician or artisan

Description	Size/Type	Quantity
Tool list for polyvalent technician	<i>List 2</i> described above	1 kit
Drain cleaner	flexible rod/wire	1
Drain rods	15 steel, plus accessories	1 set
Force cap	drain stopper	1
Gas torch		1

Continued overleaf

3c. Plumbing technician or artisan (continued)

Hammers (ball pien)	225g, 450g	1 set
Pipe threader (ratchet)	1/2" – 2" BSP, with dies	1 set
Soldering iron	solid copper type	1
Spanner (adjustable)	375mm	1
Spanners (open)	24mm – 32mm	1 set
Springs (pipe bending)	15mm, 22mm	1 set
Steel pipe cutters	12mm – 50mm	1
Tap reseater tool		1
Tin snips		1
Vice (pipe)	portable, with stand	1
Wrench (basin)	adjustable	1
Wrenches (pipe/stilson)	450mm, 600mm	1 set

3d. Carpentry technician or artisan

Description	Size/Type	Quantity
Tool list for tool polyvalent technician	<i>List 2</i> described above	1 kit
Auger bits	6mm – 32mm	1 set
Brace (carpenter's)	255mm sweep	1
Bradawl		1
Carborundum stone	double-sided coarse/fine	1
Chisels (mortice, square-edge)	6mm, 13mm	1 set
Chisels (wood, bevel-edge)	6mm, 13mm, 19mm, 25mm	1 set
Combination square		1
Files (saw/triangular)	200mm, 250mm	1 set
G-Clamps	350mm, 460mm	1 set
Glass cutter		1
Knife (hacking)		1
Knife (putty)		1
Pincers (nail)	250mm	1
Planes (bench)	size 2 smoothing, size 5 jack and spare blades	1 set
Planes (block)	adjustable 180mm, and spare blade	1 set
Planes (rebate)	duplex, adjustable, 225mm, and spare blade	1 set
Sash cramps	915mm, 1200mm, 1500mm, 1800mm	1 set
Saw (cross-cut)	24"	1

Continued opposite

3d. Carpentry technician or artisan (continued)

Saw (key hole)	with various blades	1 set
Saw (rip)	30"	1
Saw set		1
Saw (tennon)		1
Vice (carpenter's)	bench mounted	1

3e. Painting technician or artisan

Description	Size/Type	Quantity
Brushes (paint, flat)	12mm – 150mm	1 set
Compressor		1
Mask (paint spray respirator)		1
Paint roller		1
Paint scrapers	38mm, 100mm	1 set
Paint tray		1
Screwdrivers (flat and cross-head)	mix, several sizes	1 set
Spray gun (paint)	with connecting pipes	1 set
Wire brush	steel	1

3f. Welding technician or artisan

Description	Size/Type	Quantity
Tool list for polyvalent technician	<i>List 2</i> described above	1 kit
Clamps (self-grip)	sheet metal, 'C', and welding	1 set
Flint gun	with spare flints	1
Goggles (gas welding)		1
Hammer (welder's)	for chipping	1
Mask (arc welding)		1
Nozzles/reamers	assorted sizes	1 set
Spanner (adjustable)	375mm	1
Vernier caliper	300mm	1
Welder (arc)		1
Welder (gas)	combination welding and cutting	1
Welding accessories	oxy-acetylene gas bottle, gauges and pipes	1 set
Welding bench	steel and firebrick construction	1
Wire brush	steel	1

Continued overleaf

3g. Refrigeration/air-conditioning technician or artisan

Description	Size/Type	Quantity
Tool list for polyvalent technician	List 2 described above	1 kit
Feeler gauges	0.05mm – 1mm	1 set
Fridge refilling kit		1 kit
Goggles (gas welding)		1
Hammers (ball pien)	225g, 450g	1 set
Pop riveter		1
Pop rivets	assorted sizes	1 set
Punch, centre	automatic, adjustable	1
Punches, pin	2mm, 4mm, 6mm, 8mm	1 set
Spanners (socket)	4mm – 32mm, with ratchet	1 set
Springs (pipe bending)	6mm, 8mm, 10mm, 13mm	1 set
Tube cutters (copper)		1
Vacuum accessories	valves, vacuum and pressure gauges, pipes	1 set
Vacuum pump		1
Welder (gas)	combination welding and cutting	1
Welding accessories	oxy-acetylene gas bottles, gauges and pipes	1 set

Tool lists may be required for other trades such as builder/mason, automotive mechanic, and automotive electrician. However, health facilities in many counties find it more cost-effective to use private sector contractors for jobs involving these types of skills.

4. Lists of Common Shared Workshop Tools

In addition to the bench tools listed for each trade (*Lists 3a to 3g*), there are some common items that many trades can share. These shared tools should be based in the workshop. They will differ depending on the size of HTM Team and workshop.

4a. Basic workshop

Description	Size/Type	Quantity
Battery charger (lead acid)	with cables	1 set
Countersink bits (steel)	various sizes	1 set
Drill (bench)	up to 16mm	1
Drill bits (steel)	15mm – 30mm	1 set
Extension cable	25m	1
Gauge (tyre pressure)		1
Gloves (work)		3 pairs
Goggles (safety)		3

Continued opposite

4a. Basic workshop (continued)

Description	Size/Type	Quantity
Grinder (angle)	electric, handheld	1
Grinder (bench)		1
Hole cutter (sheet metal)	10mm – 30mm	1set
Hydrometer (battery)		1
Ladders (3-in-1)	aluminium	1
Ladders (triple extension)	aluminium	1
Lamp, inspection	with cage, rotary clamp, and 5m cable	1
Masks (dust)		1 pack
Planks (scaffold)		3
Pump (tyre)	foot-operated	1
Scaffold	sectional, up to 10m	1 set
Shears (sheet metal)	with stand	1
Tyre levers		1 pair

Note: Other workshop tools that we have defined as test instruments are detailed in *Box 12*.

4b. Larger, more specialist workshop

Description	Size/Type	Quantity
Tool list for basic workshop	<i>List 4a</i> described above	1 kit
Bending machine (for pipes)		1
Bending machine (for sheet metal)		1
Drill (floor-standing)		1
Lathe	small	1
Measuring tools (precision)	various	1 set
Mill	small	1
Saw (circular)	universal	1

Note: Other workshop tools that we have defined as test instruments are detailed in *Box 12*.

ANNEX 7: WORKSHOP LAYOUTS

As well as the example workshop layout shown in *Figure 17 (Section 5.3)*, *Figures 28–30* provided here show three further sample layouts for workshops undertaking district-level activities.

Figure 28: Typical Layout for a Workshop of a 50-bed Hospital

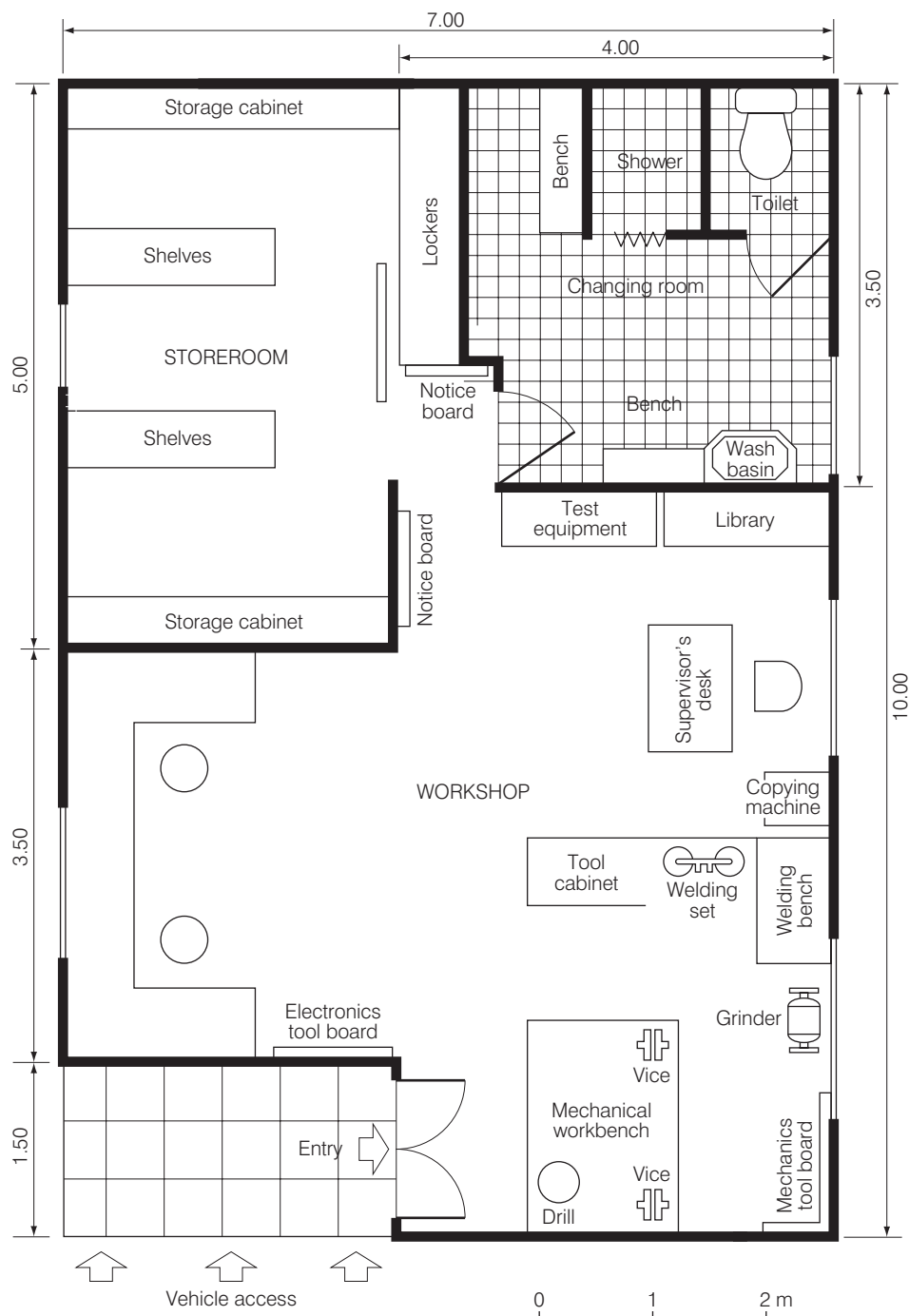

Source: WHO Regional Office for the Western Pacific, 1996, 'District hospitals: guidelines for development', 2nd edition, Western Pacific Series No.4, WHO Regional Publications, Manila, Philippines

Figure 29: Typical Layout for a District Workshop

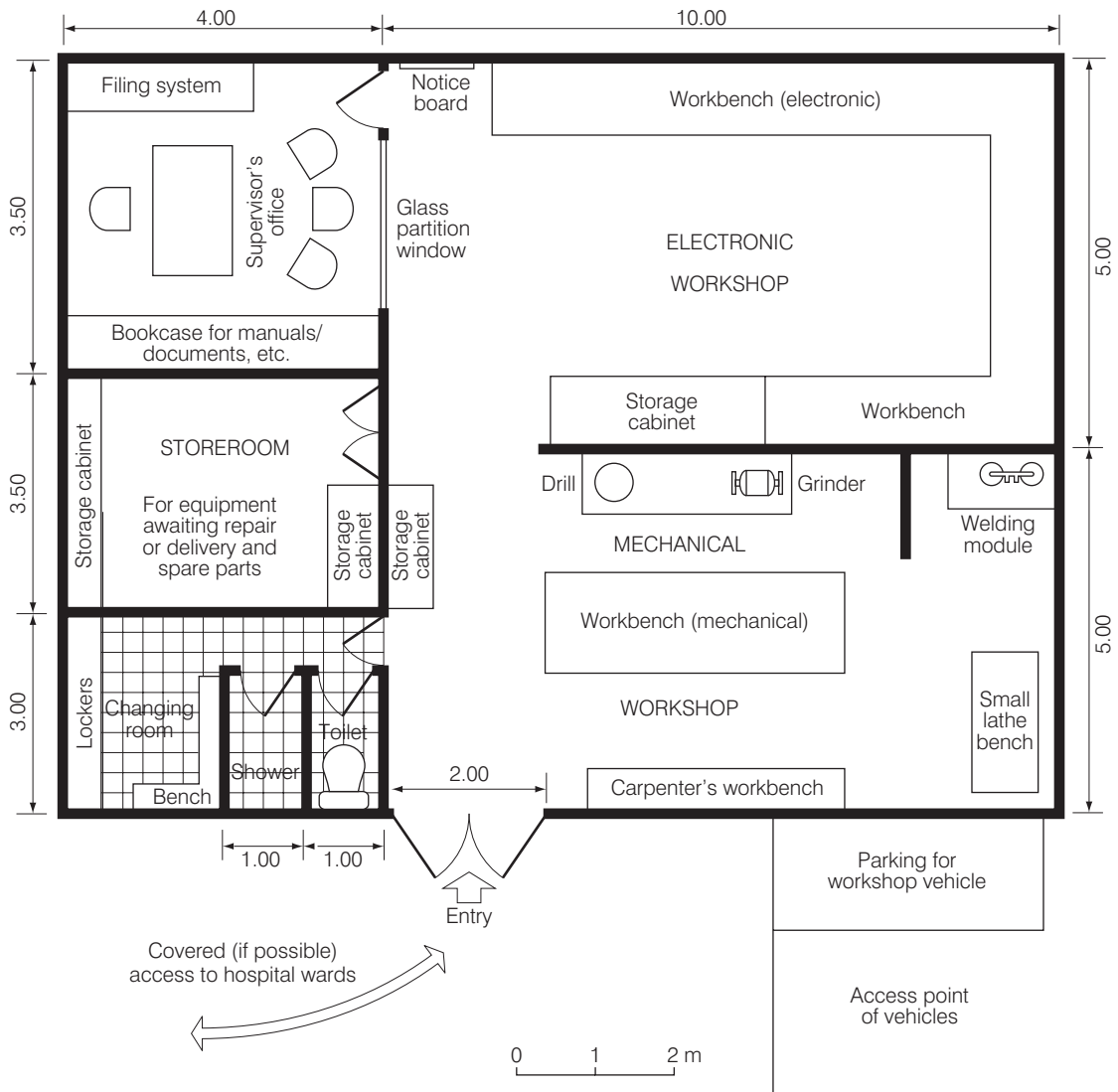

Source: Mallouppas A, 1986, 'Background document for the WHO programme on maintenance and repair of hospital and medical equipment', WHO, Geneva, Switzerland, WHO/SHS/86.5

Figure 30: Layout of a Zonal Workshop Covering an Association of Health Service Providers

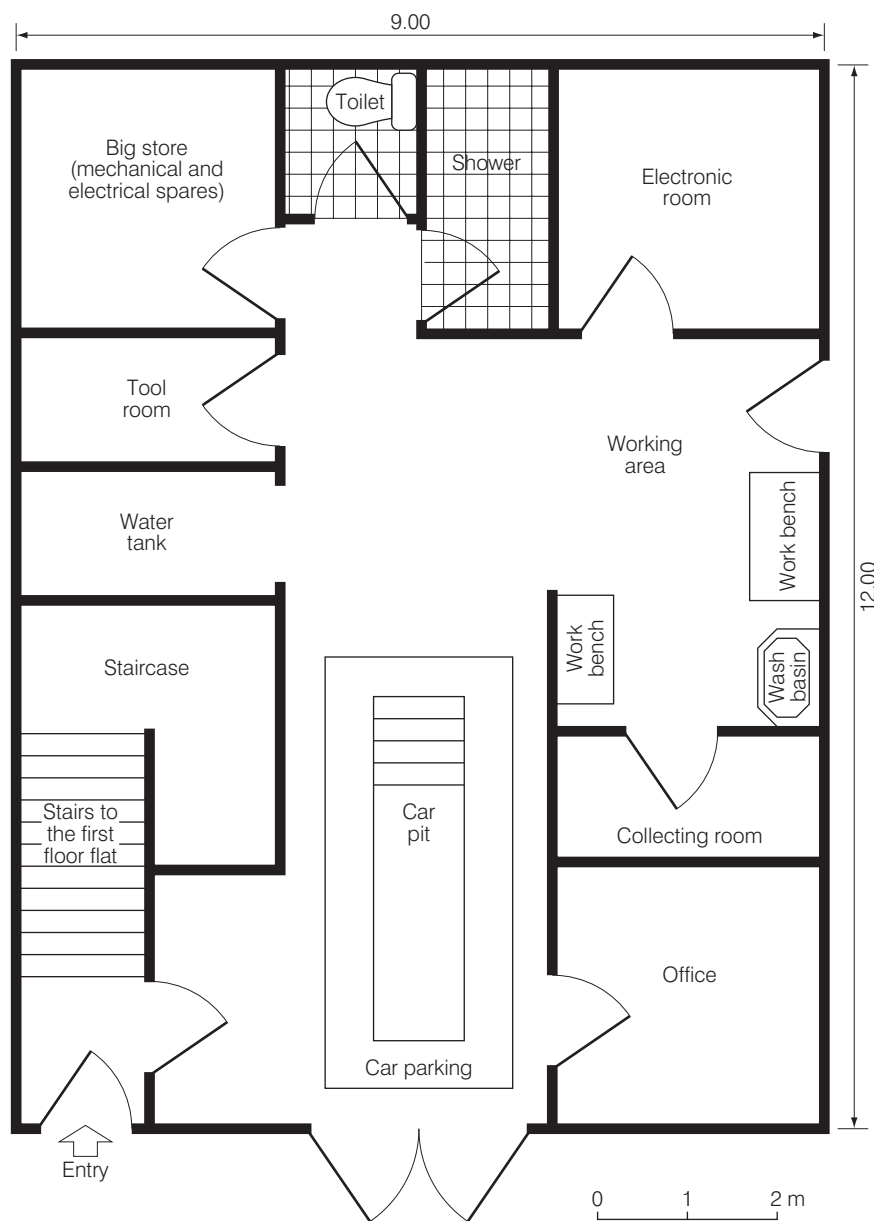

Source: FAKT, 1998, 'International seminar for hospital technicians/engineers, 28 January to 7 February 1998, Moshi, Tanzania', FAKT Publication, Stuttgart, Germany

ANNEX 8: ENTERING ITEMS INTO THE STOCK CONTROL SYSTEM

Guide 3 on procurement and commissioning describes the procedures involved when you receive equipment supplies on site and undertake the Equipment Acceptance Process. The information here summarizes the steps involved:

- ◆ During the acceptance process, the Commissioning Team compiles the following information from the available contracts, packing lists, or invoices, in order to complete a 'Register of New Stocks' form for **each** new piece of equipment received, according to a standard format (see example in *Figure 31*):
 - Type of equipment.
 - Equipment name/model.
 - Name and address of manufacturer.
 - Name and address of supplier/agent if relevant.
 - Price of equipment.
 - Manufacturer's part numbers for ordering purposes.
 - Lists of all consumables, accessories, and spare parts received, including the quantity of each, the part numbers for ordering purposes, and the price of each.
- ◆ At the successful completion of the initial training sessions (this is the training of users and maintainers undertaken when new equipment arrives), the Commissioning Team issues the accessories and consumables for immediate use to the relevant user department, together with the new equipment.
- ◆ The Commissioning Team gives a copy of the Register of New Stocks form, and the remaining, unissued, items to the Stores Controller so that they can be entered into the stores system according to the standard procedure (*Section 6.2*).
- ◆ The Stores Controller sets up the correct stock cards (bin cards) so that the stores reordering system can come into effect automatically.
- ◆ The Stores Controller enters the stores code for each item on the Register of New Stocks form, and provides the relevant user departments and the HTM Manager with lists of the new items received and their stores codes for ordering purposes.
- ◆ The HTM Manager files the Register of New Stocks form with the stores codes in the relevant equipment files (*Section 4.4*), and provides this information to the Specification Writing Group if they need assistance with updating specifications and detailing future purchase contracts (see *Guide 3* on procurement and commissioning).
- ◆ The stocks of equipment accessories, consumables, and spare parts should be issued and reordered according to the procedures given in *Sections 6.2 and 6.3*.

Figure 31: Example of a Register of New Stocks Form

Register of New Stocks Form							To be completed by the Stores Controller	
To be completed by the Commissioning Team								
Type of stock	Description	Part number	Quantity		Unit price (US \$)	Stores Code		
			Expected	Arrived				
1. Equipment Type: Manufacturer: Local supplier:	Single-bottle Suction pump, model: VP25 Eschmann Bros and Walsh Ltd Address: Peter Road, Lancing, West Sussex, BN15 8TJ, UK Tel: 00 44 1903 753322, Fax: 00 44 1903 767841	82-157-07	3	3	715.00			
	None							
2. Accessories and consumables already given to users during commissioning	Polysulfone jars, two-litre	744093	3	3	68.35			
	Rubber type jar top assembly	743057	3	3	62.16			
	Sealed disposable bacterial filter		6	6				
	Connecting tube		3	3				
	Right-angled connector		3	3				
3. Consumables	Sealed disposable bacterial filter (4 x box of 10)	82-961-70	3	3	62.40			
4. Spare parts	Disposable hydrophobic filters	82-929-14	9	9	3.75			
	Suction tubing, anti-static neoprene 6.35mm id (per metre)	696766	6m	6	1.85			
	Fuse 2-Amp delay 034-342	712954	3	3	86.95			
	Jar top assembly (VP458)	711776	6	6	15.40			
	Filter assembly 3413/Y	712949	0	0	1.50			
	Vacuum control valve	743077	3	3	33.60			
	Vacuum gauge	696499	0	0	16.85			
	Semi rotary switch green new type	744093	4	4	68.35			
	Poly jar		10	10				
	Right-angled connector (filter to tube)	745261	4	0				
	O-ring	743044	2	0				
	Diaphragm	745259	4	0				
	Valve assembly	743043	2	0				
	Plate, upper diaphragm	745258	2	0				
	Connector, inlet/exhaust	745267	2	0				
	Plate, lower diaphragm	743042	2	0				
Screw M6 x 57	733589	2	0					
Float valve cage assembly	733506	4	0					
Valve seat, rubber, float valve	710828	6m	0					
Tubing, neoprene 6.53mm id (per metre)								

ANNEX 9: EXAMPLE OF A SUPPLIES ORDER FORM

Figure 32 shows a form that can be used when ordering supplies. It acts as both a requisition voucher for goods from stores and a record of the items issued. If the voucher is produced as a standard duplicate order book, then the information can be used both by the user department as a record of the goods ordered and by stores staff for stock management purposes.

Figure 32: Sample Store Requisition and Issue Voucher

Store Requisition and Issue Voucher											
Health facility		Serial number									
Requesting department		Date		Authorized by						(Department Head)	
Requested by		(Officer)		Unit of issue						Quantity	
Stores code No.		Description		Ordered		Supplied		Unit		Cost	
1											
2											
3											
4											
5											
6											
7											
8											
9											
10											
11											
12											
										Total cost	

Approved by (Budget holder) Issued by (Stores) Date

Collected by (Requesting officer) Date

Copies: 1. Requesting department
 2. Stores file
 3. Fast copy (remains in book)

ANNEX 10: SOURCE MATERIAL/BIBLIOGRAPHY

- American Hospital Association, 1982, 'Medical equipment management in hospital', AHA, Chicago, USA.
- American Society for Hospital Engineering, 1998, 'Estimated useful lives of depreciable hospital assets', 2nd edition, American Hospital Association, Chicago, USA
- Amonoo-Larston R, Ebrahim G, Lovel H, and J Ranken, 1996, 'District health care: Challenges for planning, organization and evaluation in developing countries', 2nd edition, Macmillan, ISBN: 0 333 57349 8
- Atom Medical Corporation, 1998, 'Operator and service manuals for infant incubator V850W-SC', Atom Medical Corporation, Tokyo, Japan
- Bloom G H, and C L Temple-Bird, 1988, 'Medical equipment in sub-Saharan Africa: A framework for policy formulation', IDS Research Report Rr19, and WHO publication WHO/SHS/NHP/90.7, ISBN: 0 903354 79 9
- Centre for Medical Electronics, 1995, Maintenance record system, St.Bartholomew's Hospital, London, UK
- David Y, and T Judd, 1993, 'Medical technology management', BioPhysical Measurement Series, SpaceLabs Medical Inc, Washington, USA, ISBN: 0 9627449 6 4
- Deller, A., 1994, 'Notes on electrical safety', Centre for Medical Electronics, St.Bartholomew's Hospital, London, UK, unpublished
- Ellis J, 1999, 'Human resources policy and procedure manual: KANDO hospital management project', Ministry of Health Zambia/DFID, Ziken International Consultants Ltd, Lewes, UK
- Eschmann, 1995, Maintenance record system, Eschmann Bros. and Walsh Ltd, Lancing, UK
- FAKT, 1995, 'The equipment management cycle: A new tool for planning health care technical services', FOCUS No.12, June 1995, FAKT, Stuttgart, Germany
- FAKT, 1998, 'International seminar for hospital technicians/engineers, 28 January to 7 February 1998, Moshi, Tanzania', FAKT Publication, Stuttgart, Germany
- Haddon B, 1995, 'Annual work planning', Paper 401 in *Making hospitals work better, volume II: Working papers on hospital management and organisation – KANDO hospital management project*, Ministry of Health, Zambia/DFID, Ziken International Consultants, Lewes, UK
- Haddon B, 1995, 'Monitoring targets and work performance', Paper 402 in *Making hospitals work better, volume II: Working papers on hospital management and organisation – KANDO hospital management project*, Ministry of Health, Zambia/DFID, Ziken International Consultants, Lewes, UK
- Halbwachs H, 1992, 'The Madagascar experience', in Berche T, *The district hospital: WHO-IMT-GTZ workshop report*, Yaounde, Cameroon, GTZ, Eschborn, Germany
- Halbwachs H, 1993, 'Health care equipment management in developing countries', in *CAMPBE Review* Vol 1 No.1 12/1993
- Halbwachs H, 1993, 'Maintenance and the district health system: Approach and perspectives', in *Maintenance for health systems: Report of the 4th GTZ workshop in Dakar, Senegal, September 1993*, GTZ, Eschborn, Germany
- Halbwachs H, 1999, 'The importance of maintenance and repair in health facilities of developing economies', GTZ, Eschborn, Germany
- Halbwachs H, 1999, 'The technical and financial impact of systematic maintenance and repair services within health systems of developing countries', in *Health Estate Journal*, May 1999

- Halbwachs H, 2001, 'Physical assets management and maintenance in district health management' GTZ, Eschborn, Germany
- Halbwachs H, and B Miethe, 1994, 'Computerizing maintenance for health care facilities in developing countries', GTZ, Eschborn, Germany
- Halbwachs H, and A Issakov (eds), 1994, 'Essential equipment for district health facilities in developing countries', GTZ/WHO, Eschborn, Germany
- Halbwachs H, and R Werlein, 1993, 'Training health personnel to operate health-care equipment: How to plan, prepare and conduct user training – A guide for planners and implementors', GTZ, Eschborn, Germany
- Johnstone P, and J Ranken, 1994, 'Management support for primary health care: A practical guide to management for health centres and local projects', FSG Communications Ltd, Cambridge, UK, ISBN: 1 87118 02 4
- Jorgensen T, and A Mallouppas, 1989, 'Health care equipment planning, selection and procurement', presented at the WHO/DANIDA Interregional Training Workshop on Health Care Equipment Management: 10 – 26 July 1989, Arusha, Tanzania
- Kaur, M., & S. Hall, 2001, 'Medical Supplies and Equipment for Primary Health Care: A practical resource for procurement and management', ECHO International Health Services Limited, ISBN: 0-9541799-0-0
- Kwankam Y et al, 2001, 'Health care technology policy framework', WHO Regional Publications, Eastern Mediterranean Series 24: Health care technology management, No.1, ISBN: 92 9021 280 2
- Lee P, 1995, 'Get it right!: A guide to maintenance, safety precautions and hygiene of medical equipment', draft, ECHO International Health Services Ltd, UK, unpublished
- Mallouppas A, 1986, 'Background document for the WHO programme on maintenance and repair of hospital and medical equipment', WHO, Geneva, Switzerland, WHO/SHS/86.5
- Marshall-Fowler, 1997, 'Service manual for electrode boiler ES90', Marshall-Fowler (South Africa) (Pty) Limited, Gauteng, South Africa
- McGloughlin B, 1999, 'Accounting policies and procedures manual: KANDO hospital management project', Ministry of Health Zambia/DFID, Ziken International Consultants Ltd, Lewes, UK
- Mehta JC, 1983, 'Engineering and maintenance services in developing countries', in *Approaches to planning and design of health care facilities in developing areas, Vol 4*, Kleczkowski BM et al (eds), WHO Offset Publication No 72, WHO Geneva, ISBN: 924 170072 6
- Ministry of Health of Botswana, 1991, 'Central medical stores ordering lists 1991/1992', MOH, Gaborone, Botswana
- Neureiter J, and A Tschank, 1989, 'Technician's handbook for hospital engineering', Kenyan-Austrian Development Cooperation, Ministry of Foreign Affairs, Austria
- Paton J, Green B, and J Nyamu, 1996, 'The division for the supply of medical spare parts in the health system of Kenya', Ministry of Health, Nairobi/GTZ, Eschborn, Germany
- Pearson A, 1995, 'Medical administration for frontline doctors: A practical guide to the management of district-level hospitals in the public service or in the private sector', 2nd edition, FSG Communications Ltd, Cambridge, UK, ISBN: 1 871188 03 2
- Raab M, 1999, 'Maintenance strategies', Swiss Centre for International Health, Basel, Switzerland
- Raab M, 1999, 'Strategic medical technology planning and policy development', Swiss Centre for International Health, Basel, Switzerland

- RCM Consultants/Kgalagadi Breweries Ltd, 1992, Maintenance record system, Kgalagadi Breweries Ltd, Gaborone, Botswana
- Remmelzwaal B, 1997, 'The effective management of medical equipment in developing countries: A series of five papers', FAKT, Stuttgart, Germany
- Remmelzwaal B, and E de Villiers (eds), 2002, 'Where there is no technician: A practical guide for users of medical equipment', Ministry of Health and Social Services, Windhoek, Namibia
- Skeet M, and D Fear, 1995, 'Care and safe use of hospital equipment', VSO Books, London, ISBN: 0 9509050 5 4
- Temple-Bird C L, 1990, 'Equipment management course notes: Postgraduate diploma in medical electronics and medical equipment management', Department of Medical Electronics and Physics, Medical College of St. Bartholomew's Hospital, London, UK, unpublished
- Temple-Bird C L, 2000, 'Practical steps for developing health care technology policy', Institute of Development Studies, University of Sussex/Ziken International Consultants, Lewes, UK, ISBN: 1 85864 291 4
- Temple-Bird C, Bbuku T, and the Equipment and Plant Sub-Group, 2000, 'Equipment management policies and procedures manual: KANDO hospital management project', Ministry of Health, Zambia/DFID, Ziken International, Lewes, UK
- Temple-Bird C, Bbuku T, and F Kamanga, 1995, 'Proceedings of the planning workshop to develop maintenance systems', Annex V of the *October 1995 Consultancy Report: KANDO hospital management project*, Ministry of Health, Zambia/DFID, Ziken International, Lewes, UK
- Temple-Bird CL, Mhiti R, and GH Bloom, 1995, 'Medical equipment in Botswana: A framework for management development', WHO, Geneva, WHO/SHS/NHP/95.1
- Temple-Bird C and H Halbwachs, 1991, 'Spare parts and working materials for the maintenance and repair of health care equipment: Report of workshop held in Lübeck August 1991', GTZ, Eschborn, Germany
- West of Scotland Health Boards, 1985, 'Acceptance and routine testing of medical electrical equipment', Test and Check Procedures Book 5, Physicare, Glasgow, UK
- WHO, 1987, 'Interregional meeting on the maintenance and repair of health care equipment: Nicosia, Cyprus, 24-28 November 1986', Geneva, Switzerland, WHO/SHS/NHP/87.5
- WHO, 1990, 'WHO interregional meeting on manpower development and training for health care equipment management, maintenance and repair: Campinas, Brazil, November 1989', Geneva, Switzerland, WHO/SHS/NHP/90.4
- WHO, 1994, 'Maintenance and repair of laboratory, diagnostic imaging, and hospital equipment', WHO, Geneva, Switzerland, ISBN: 92 4 154463 4
- WHO, 1998, 'District hospitals: Guidelines for development', 2nd edition, WHO Regional Publications: Western Pacific Series No 4, Manila, Philippines, ISBN: 92 9061 117 0
- WHO, 2000, 'The world health report 2000: Health systems – Improving performance', WHO, Geneva, Switzerland, ISBN: 92 4 156198 X
- WHO, Department of Health Service Provision, Presentation slides on healthcare technology management, WHO, Geneva, Switzerland
- WHO, Expanded Programme on Immunisation (EPI), 1984, 'Logistics and cold chain for primary health care: Technician's handbook for compression refrigerators – Part D, How to keep stocks of spare parts', No.20, WHO, Geneva, Switzerland, EPI/LOG/84/20

‘How To Manage’ Series for Healthcare Technology

This Series of Guides helps you to get the most out of your investment in healthcare technology. You need to manage your assets actively, ensuring that they are used optimally and efficiently. This series shows you how.

Physical assets such as facilities and healthcare technology are the greatest capital expenditure in any health sector. Thus it makes financial sense to manage these valuable resources, and to ensure that health care technology:

- ◆ is selected appropriately
- ◆ is used correctly and to maximum capacity
- ◆ lasts as long as possible.

Such effective and appropriate management of healthcare technology will contribute to improved efficiency within the health sector. This will result in improved and increased health outcomes, and a more sustainable health service. This is the goal of healthcare technology management – the subject of this Series of Guides.

The Guides

Guide 1: How to Organize a System of Healthcare Technology Management

Guide 2: How to Plan and Budget for your Healthcare Technology

Guide 3: How to Procure and Commission your Healthcare Technology

Guide 4: How to Operate your Healthcare Technology Effectively and Safely

Guide 5: How to Organize the Maintenance of your Healthcare Technology

**Guide 6: How to Manage the Finances of your Healthcare Technology
Management Teams**