



USAID
FROM THE AMERICAN PEOPLE



**World Health
Organization**

REPORT
OF A
**CONSENSUS CONFERENCE
ON WHEELCHAIRS FOR DEVELOPING COUNTRIES**

BENGALURU, INDIA
6-11 NOVEMBER 2006

EDITED BY
SARAH SHELDON
AND
NORMAN A JACOBS

ACKNOWLEDGEMENTS

The conference was held in collaboration with the Leahy War Victims Fund of USAID, WHO, the Center for International Rehabilitation, Motivation, Whirlwind Wheelchairs International, Disabled People's International and Mobility India. The funding was provided by USAID (Grant Number HRN-G-00-00-00015-00) ISPO, and a number of individual organizations who provided support for their representatives.

The Society undertook the arrangements for the conference.

Mobility India provided the local organization in Bengaluru which the organisers gratefully acknowledge.

The Organizing Committee thank all the presenters and participants for their active contributions throughout the conference. In addition they thank the staff of Mobility India who worked tirelessly in providing the administrative and technical support which made the conference such a great success.

ORGANISING COMMITTEE

LWVF/USAID:	Rob Horvath (Chairman)
WHO:	Chapal Khasnabis
Motivation:	David Constantine Sarah Sheldon
Center for International Rehabilitation:	Kim Reisinger
Whirlwind Wheelchair International:	Marc Krizack
Consumer representative:	Venus Ilagan (DPI)
ISPO:	Sepp Heim J Steen Jensen Anna Lindstrom Geoff Bardsley Norman A Jacobs (Rapporteur) Karen Schmidt (Secretary)

CONTENTS

Organisation and outcomes		1
Background	Sarah Sheldon & Norman A Jacobs	3
Conclusions and recommendations		5
Syndicates		
Syndicates A		13
Syndicates B		25
Syndicates C		39
Syndicates D		53
Syndicates E		67
Syndicates F		81
Conference papers		93
Needs, poverty and inclusion		
Needs, human rights access	Chapal Khasnabis	95
User participation	Venus M Ilagan	98
Approaches to wheelchair provision from USAID's perspective	Lloyd Feinberg	102
Review session		
Review of literature on wheelchairs for developing countries & Review of wheelchair provision in developing countries	Jon Pearlman	104
User satisfaction survey: an assessment study on wheelchairs in Tanzania	Tone Øderud, J Steen Jensen, John E Lyimo, Abdullah Munish & Paul Shunda	112
Discussion: Needs, poverty and inclusion & Review session		118
Services		
Referral, assessment and prescription, fitting, basic user training (including peer group training)	Chapal Khasnabis & Federico Montero	121
Follow-up, service and maintenance (including repairs and maintenance), sustainability of service, service delivery system	Abdullah Munish	123

Community based services: Mobility India	Albina Shankar	126
DPO based services: Disabled Women's Support Organisation, Zimbabwe	Gladys Charowa	128
Institutional-governmental services: China Service for Development & Supply of Devices for Disabled	Chen Guang	130
NGO with governmental purchasing: Motivation Romania Foundation	Cristian Ispas	132
Discussion: Services		139

Products

Designs (including tricycles)	Tone Øderud	141
Specific designs:		
▪ Motivation	David Constantine	160
▪ Whirlwind RoughRider™	Ralf Hotchkiss	163
▪ HI Philippines tricycle	Matt McCambridge	167
▪ Wheelchair Foundation	Joel Hodge	186
▪ Free Wheelchair Mission	Michael Bayer & Don Schoendorfer	187
Postural support including supportive seating	Shona McDonald	190
Pressure relief cushions	Jamie Noon	203
The role of user feedback in research and design	Jon Pearlman	211
Discussion: Products		215

Production

Methods of production, test standards, quality control, cost, sustainability	Ray Mines	217
Experience in production facilities:		
▪ Local: MADE, Uganda	Fatuma Acan	221
▪ Regional: CIR, USA + Worth Trust, India	Kim Reisinger	223
▪ Global: Shanghai Hubang Medical Appliance Co Ltd, China	Fang Lizhong	229
Experiences of strength testing and field trials	Stefan Constantinescu	231
Discussion: Production		237

Supply and distribution

Cost sharing, supply, use of the stakeholders, distribution	Kylie Mines	239
Supply and distribution systems:		
▪ Local community: Disacare, Zambia	David Mukwasa	244
▪ Camp approach: ALIMCO, India	Atul Dubey	247
▪ Large scale distribution: Wheelchair Foundation, USA	Joel Hodge	248
▪ IBR/CBR approach, Interlife, Bangladesh	Johan Borg	251
▪ A country-wide view, MoH, Uganda	Fredrick Semakula	256
Discussion: Supply and distribution		259

Capacity development

Organisational capacity building, what is needed to establish wheelchair service provision, building the organisation, training personnel, sustainability	Geoff Bardsley	261
Organisational capacity:		
▪ Albania Disability Rights Foundation	Florida Kalemi	263
▪ APD Bangalore, India	VS Basavaraju	266
Training:		
▪ Forman training: TATCOT/Motivation	Yona Ezekiel Gyundi & Christine Cornick	268
▪ Modular approach: Mobility India	Ritu Ghosh	270
▪ Skill development in a production context	Philippe Mazard	272
▪ Short courses in assessment and prescription/assembly and fitting	Kylie Mines	276
▪ Capacity development of the clinic team	Michiel Steenbeek	278
Discussion: Capacity development		280

Guidelines for wheelchair provision

Introduction to draft WHO guidelines	Kim Reisinger
--------------------------------------	---------------

Appendices

Appendix A: Conference programme	293
Appendix B: Participants	301

ORGANISATION AND OUTCOMES

Background

Sarah Sheldon and Norman A Jacobs

The Consensus Conference on Wheelchairs for Developing Countries is the latest in a series of conferences on appropriate orthopaedic technology for developing countries. It follows on from the Consensus Conferences on Appropriate Prosthetics for Developing Countries held in Phnom Penh Cambodia in 1995, Appropriate Orthopaedic Technology for Low-Income Countries held in Moshi Tanzania 2000, and Appropriate Lower Limb Orthotics held in Hanoi Vietnam in 2006.

The purpose of this conference was to bring together as many of the groups as possible which are involved in the delivery of wheelchairs and the provision of wheelchair services in developing countries and provide a forum for discussing the different issues related to these topics. In particular the conference covered the following topics:

- Needs, poverty and inclusion
- Services
- Products
- Production
- Supply and distribution
- Capacity development
- Guidelines for wheelchair provision

This conference was organized by the International Society for Prosthetics and Orthotics (ISPO) in collaboration with the Leahy War Victims Fund of the United States Agency for International Development (LWVF-USAID) and the World Health Organization (WHO) with the help of the Center for International Rehabilitation, Motivation, Whirlwind Wheelchairs International and Disabled Peoples International. The local organizers were Mobility India, Bengaluru.

The meeting was attended by representatives of all the major agencies involved in the delivery of wheelchairs and the provision of wheelchair services in the developing world. ISPO, LWVF-USAID and WHO are grateful for the input that they made in presenting background papers and the contributions they made in the ensuing discussions.

This publication reports on the work of the conference and contains the background papers and their discussions, detailed reports of the syndicate discussions on selected topics, the resulting plenary discussions, and the final conclusions and recommendations.

ISPO appreciates the efforts of all the people involved in this meeting and hopes that this report of this conference goes some way to help improve the wheelchair provision services in developing countries.

Conclusions and recommendations

Wheelchair

Purpose of a wheelchair

- The fundamental purpose of a wheelchair is to promote mobility, inclusion and enhanced quality of life of the user

Definition of a wheelchair

- An assistive device which enhances personal mobility and facilitates participation, for a person with walking limitation (WHO definition)
- A technical aid intended to provide wheeled mobility and body support for individuals with impaired mobility to walk (ISO 7176-26: Wheelchairs - Vocabulary, FDIS 2005)
- A device to provide wheeled mobility with a seating support system for a person with a walking limitation (ISO definition modified by the conference)
- It is recommended that ISO revise its definition of a wheelchair in order to take account of the currently accepted terminology

Definition of an appropriate wheelchair

- A wheelchair is appropriate when it meets the individual's needs and environmental conditions; provides proper fit and postural support based on sound biomechanical principles; is safe and durable; is available and can be accessed, maintained and sustained in the country at the most economical and affordable price.

User involvement

- *"It is about the user, not just about the wheelchair"*. Wheelchair users should be involved in all aspects of wheelchair provision.

Needs

Needs assessment

- According to WHO it is estimated that about 10% of the population are people with disabilities. Studies also show that about 10% of people with a disability require a wheelchair
- There is no accurate figure for the number of people in developing countries that require a wheelchair. It is estimated that about 1% in any given population, i.e., about 65 million people worldwide require a wheelchair.
- Anecdotal evidence indicates a very small minority of those in need have access to an appropriate wheelchair.
- More accurate data of the needs are required to be collected in order to be able to address them.
- It is important to develop and implement standardized tools and methodology for data collection.
- The number of people who need wheelchairs is so large that all efforts should contribute towards developing long-term sustainable services.

Outcome measures

- Reliable record keeping is essential for all phases of wheelchair provision including assessment, prescription, fitting, delivery and follow-up.

- Regular follow-up/evaluation of outcomes of wheelchair provision should be performed.
- User satisfaction surveys must be an integral part of outcome assessment.
- User satisfaction surveys should be performed and include measures of the impact of wheelchair provision on the quality of life of the user.

Information sharing

- There is a lack of shared information about resources, activities and initiatives which may result in a duplication of efforts and gaps in services. The establishment of a website and/or an accessible database would be of benefit to those involved in wheelchair provision.

Services

(Note: in this document Wheelchair Services refers the service delivery of wheelchairs to the individual users. Wheelchair Provision refers to the overall subject including design, manufacture distribution and services)

- Wheelchair services are an integral part of wheelchair provision.
- User participation is an integral part of wheelchair services.
- Wheelchair services should be delivered by trained personnel.
- Government has the primary responsibility for sustainable wheelchair service. Wheelchair services should be an integral part of national strategies.
- The wheelchair services are encouraged to ensure that people with disabilities from all sectors of society are provided with appropriate wheelchairs including those from marginalised and vulnerable groups such as women and children.
- The aim of wheelchair services is to ensure that the person in need of a wheelchair receives it together with the necessary information and support. The wheelchair should meet the individual's needs in terms of mobility, appropriate fit, comfort, safety and ability to carry out activities of daily living and exercise basic human rights.
- The following table was agreed as a first draft of specifying the elements and requirements for wheelchair services:

Elements	Requirements
Awareness	<ul style="list-style-type: none"> ▪ Basic information about needs for and benefits of using wheelchair (e.g. leaflet with information about who needs a wheelchair which is distributed to different organisations based on available services (to avoid expectations that cannot be met)) ▪ Involvement of CBR/community health/educational personnel ▪ Involvement of DPOs

Identification/ screening/ referral/ networking	<ul style="list-style-type: none"> ▪ Identify and inform people who may need a wheelchair to enhance mobility ▪ Simple screening tool to identify those who can benefit from the use of a wheelchair, to identify the complexity, to understand if the needs can be met with available services, and to identify what other needs the person has ▪ To identify simple to complicated interventions ▪ Identify referral pathways ▪ Networking with local government and community development organisations ▪ Use existing resources/network (human resources) ▪ System for registration (for follow-up) to identify what services need to be developed
Assessment	<ul style="list-style-type: none"> ▪ Individual assessment (e.g. with an assessment tool which can be adapted or modified depending on situation and context) ▪ Assess medical/health/functional condition ▪ Individual rehabilitation plan ▪ By trained people ▪ Involvement of user ▪ Establishing a waiting list
Specification of wheelchair/ prescription/ selection	<ul style="list-style-type: none"> ▪ Technical and functional description of a suitable wheelchair ▪ Information about available wheelchair ▪ Need for modifications/adjustments ▪ Need for extra equipment ▪ Basic guide for self-care ▪ List of individual needs ▪ Wheelchairs meet an appropriate standard (as yet to be defined)
Procurement	<ul style="list-style-type: none"> ▪ Choose supplier ▪ Funding ▪ Minimise the delivery time of the wheelchair
Product preparation	<ul style="list-style-type: none"> ▪ Assembly, if necessary ▪ Cushion ▪ Adaptation, modification and/or customisation of the seating system
Fitting	<ul style="list-style-type: none"> ▪ User trial in local environment ▪ Necessary alterations ▪ Finalisation of wheelchair
User training	<ul style="list-style-type: none"> ▪ Basic training should include safety, transfer, basic mobility/handling, basic maintenance, self care/pressure relief, who to contact if something goes wrong, impact/risk of self-modification ▪ Final check-out
Repair and maintenance	<ul style="list-style-type: none"> ▪ Local repair ▪ Provision of basic spare parts
Follow-up	<ul style="list-style-type: none"> ▪ Re-assessment, specially of users with progressing/changing conditions ▪ Use of existing networks, e.g. CBR
Accessibility	<ul style="list-style-type: none"> ▪ Facilitate home modifications/barrier-free environment including lobbying and taking part in the process where possible
General Management	<ul style="list-style-type: none"> ▪ Coordination of donations/government funding ▪ Development of services ▪ Sustainability ▪ Financing plan (including subsidy) ▪ Network of service providers/users ▪ Collaboration between different stakeholders in provision of appropriate wheelchair services ▪ User involvement/feed-back ▪ Evaluation of service provision

Footnote: Not all elements and requirements are essential, some could be considered as only desirable depending on the context and the socioeconomic conditions that prevail.

Products

- As a minimum, developing countries are encouraged to adopt the wheelchair ISO standards as they exist at present, particularly:
 - ISO 7176 - 8: Wheelchairs - Requirements and test methods for static, impact and fatigue strengths, 1998
 - ISO 7176 - 1: Wheelchairs - Determination of static stability, 1999
 - ISO 7176 - 3: Wheelchairs – Determination of the efficiency of brakes, 2003
 - ISO 7176 - 5: Wheelchairs – Determination of overall dimensions, mass and turning space, DIS 2005
 - ISO 7176 -15: Wheelchairs - Requirements for information disclosure, documentation and labelling, 1996, and
 - ISO 7176 -16: Wheelchairs - Requirements and test methods for resistance to ignition of upholstered parts, 1997

These represent the minimum requirements for wheelchairs provided in these countries.

- Organisations importing wheelchairs are encouraged to ensure that the wheelchairs meet ISO standards or the wheelchair standards existing in that particular country, whichever is higher.
- There is a need to develop more demanding versions of ISO standards to represent the more challenging conditions in developing countries.
- It was recommended that ISO be requested to revise the existing standards to take into account the needs in developing countries.
- Test methods should be designed to replicate usage in the relevant environments (based on an average life expectancy of 5 years).
- It is recommended that a representative sub-committee be identified to propose requirements within each category outlined in the table below:

Static stability	Front, lateral, diagonal and backward tipping for least and most stable axle positions.
Effectiveness of brakes	ISO standard with set angle for tipping of chair and angle at which brakes hold, test for sudden release of the brakes.
Strength durability	Stress testing of front casters, structural integrity, peak force or yield failures and double drum (fatigue) test.
Pressure relief cushion (compulsory)	Ratings for cushions, determine levels. Standard test using indenter, concern about cushion changing centre of gravity, life of cushion, develop test equipment.
Safety	Pinch points and sharp edges, self-locking nuts.
Dynamic stability	Declining ramp with obstruction to cause abrupt stop of wheelchair (testing to assure wheelchair user remains in wheelchair after abrupt stop).
Adjustability	Footrest adjustment range, brake adjustment. Information about armrest height, backrest height range, range of seat width/depth and fore/aft rear wheel position.
Postural support	All body contact surfaces supporting adequately (e.g. footrests). Wait for ISO standards on postural support devices. Sub-committee will revisit within 6 months and make recommendations.

Quality of manufacture	Durability testing, sample size and frequency for product testing (quality control), sharp edges and points, corrosion resistance, fit and finish.
Availability of components	Manufacturer to ensure availability or provision of needed parts, reporting of any hard-to-find parts/components. Work towards common components/parts across different manufacturers. Consumables separate from replacement parts.
Rolling resistance	Resistance to movement over a range of surfaces such as grass, mud and sand.
Reflectors	All wheelchairs should be fitted with robust reflectors on all sides to increase their visibility within traffic.
Other	Tracking, transportability, include note on handrims and wheel size.

- It was further agreed that there would be value in testing current wheelchair designs. Each of the organizations represented at the consensus conference agreed to participate.

Production

Standards and guidelines

- All wheelchairs, whether locally produced or imported, and whether made in small, medium or large scale enterprises should meet or exceed ISO standards.

User choice

- Stakeholders are encouraged to recognise the right of wheelchair users to choose their wheelchair and to work in collaboration with the user.
- Users' needs are best met when there is a variety of wheelchair models from which to choose.

Acquiring wheelchairs

- When determining whether to acquire wheelchairs via import or local production, decision makers are advised to balance a variety of factors. These include needs of the local population, quality and variety of wheelchair models, purchase price, cost of repair and replacement, effect on local employment and wheelchair production, and national policies and strategies including long-term sustainability.

Locally repairable

- Regardless of scale and location of production, wheelchairs must be locally repairable.

Distribution

- There is a vast need for appropriate wheelchairs in developing countries and it is recognised that there are different methods of wheelchair distribution which are not mutually exclusive but can complement each other.
- All methods of distribution have a part to play and stakeholders are encouraged to work closely together to ensure that there is no duplication of effort and waste of resources.
- It is recommended that, irrespective of method of distribution:
 - the provider has the capacity to provide the wheelchairs in a reasonable and responsible manner;

- the distribution is based on an assessment of the situation in the country or the region of the country and considers the impact on local wheelchair producers and service providers;
- procured wheelchairs meet or exceed relevant international standards and be appropriate for the environment of use;
- wheelchairs are provided following a provision process that meets or exceeds internationally agreed minimum requirements for service provision, including requirements for assessment, fitting, user training and follow-up;
- wheelchairs are repairable in the region of the country where they are provided or expected to be used.
- distributors coordinate their distribution with national and local governments as well as producers and providers of wheelchairs in the country; and
- distributors of wheelchairs network with each other.

Training and education

- It is recognized that training and education are key elements for developing, introducing, maintaining and building sustainable wheelchair services.
- All stakeholders need to be trained and/or informed regarding their roles in wheelchair provision.
- All individuals involved in wheelchair services should be trained. These may include:
 - Physiotherapists
 - Occupational Therapists
 - Doctors
 - Nurses
 - Prosthetists and Orthotists
 - Engineers/Technologists/Technicians
 - CBR personnel
 - DPO/Rights group members
- In particular the user and assistant must be properly informed and trained.
- Comprehensive information should be provided to governments, decision makers, donors and other stakeholders.
- Training and education for stakeholders can be divided into four types:
 - Formal training to establish specialists in wheelchair provision where possible.
 - Special modules for other individuals involved in wheelchair provision.
 - Comprehensive information for different stakeholders (including government, decision makers and donors)
 - structured/formalized peer training for users and assistants.
- Professional profiles for specialists in wheelchair provision should be developed
- An expert group under the umbrella of an internationally recognized organization should:
 - develop the professional profiles for the training of people involved in wheelchair service provision

- specify the content of the various training, education and information modules required

WHO Guidelines

- The importance of developing the *WHO Guidelines on the provision of manual wheelchairs in less resourced settings* is recognized.
- In order that the guidelines be effective as soon as possible, it is recommended that WHO quickly incorporate the outcomes from this consensus conference into the guidelines and share a draft of the revised guidelines with a larger audience for review.

Syndicates A

Questions: Syndicates A

1. Based upon the conference programme, in what areas would you like to see consensus reached? Identify the three areas in which you would consider the priority for consensus to be reached.

(Syndicates A1, A2, A3, A4)

2. What are the various elements necessary to provide appropriate wheelchairs in developing countries?

(Syndicates A1, A2)

3. What is the current adequacy of wheelchair provision in developing countries?

(Syndicates A3, A4)

Syndicate A1 report

Chair: Isabelle Urseau
Rapporteur: Christine Cornick

Participants: Bayer
Chen Guang
Constantine
Dubey
Fang Lizhong
He Jinming
Ispas
Khasnabis
Madziranzina
Nanda, R
Scheffler
Semakula
Suvapan
Umarshankar

1. **Based upon the conference programme, in what areas would you like to see consensus reached? Identify the three areas in which you would consider the priority for consensus to be reached.**

The syndicate would like to reach consensus on:

- The minimum skills and knowledge level for people distributing wheelchairs
- Which wheelchair designs are appropriate for which situation
- Responsibilities of different stakeholders

2. **What are the various elements necessary to provide appropriate wheelchairs in developing countries?**

Service provision:

Assessment for recommendation of appropriate device, adequate repair/availability of replacement parts, postural review and follow up, waiting list system by device, data system to record users at national level, referral network

Training:

Capacity development of skills is required at different levels and in different settings; user/carer training in maintenance and use; training of peer group trainers (wheelchair user to wheelchair user).

Product standards:

Types of products/design production methods: local, regional, global/supportive seating/cushions

Minimum standards:

Minimum standards for all of above areas

Information sharing:

Promote the establishment of a national body (e.g. within Ministry or National Federation) to coordinate wheelchair activity and set and enforce minimum standards, along the lines of the prosthetics and orthotics model. Establish a committee from this conference to see how we can coordinate information sharing on an international level.

Funding:

Funding is needed for all aspects of wheelchair provision: service provision, products and training. Funding can be mix of government/donor/donations of products.

Syndicate A2 report

Chair: Claude Tardif
Rapporteur: Alida Lindsley

Participants: Armstrong
Castellon
Constantinescu
Gall
Hodge
Ilagan
Mazard
Mukwasa
Ndjambula
Pearlman
Schoendorfer
Shangali
Vennila

- 1. Based upon the conference programme, in what areas would you like to see consensus reached? Identify the three areas in which you would consider the priority for consensus to be reached.**

Agreed upon minimum standards for:

Planning of national wheelchair service

These topics were mentioned:

- Greater involvement of consumer perspective in wheelchair provision (development, production and distribution),
- Gender balance,
- Advocate for the needs of children with disabilities (especially cerebral palsy); more choice and availability of equipment for children,
- Meet the needs of poorer wheelchair users,
- Sustainability of services,
- How groups work together: cooperation and understanding of large scale and small scale,
- Marketing solutions,
- Evaluation: assess quality of provision and demonstrate results; outcome studies (especially user's quality of life); what kind of studies?; develop a common protocol.

Appropriate wheelchair technology

Including:

- Designs of wheelchairs,
- Production/process of manufacture,
- Materials, parts to use,
- Fit of wheelchair to individuals,
- Quality,
- Training of manufacturers,
- Ways to support of wheelchair manufacturers, especially in Africa (e.g. forming an association of wheelchair manufacturers for efficiency of purchasing).

Assessment and evaluation

Including:

- How to provide the technology,
- Comprehensive services,
- Training personnel,
- Training users,
- Quality assurance,

- Evaluation of quality of services,
- Distribution of wheelchair and services,
- Distribution and supply of wheelchairs (the right wheelchair for the individual).

2. What are the various elements necessary to provide appropriate wheelchairs in developing countries?

- a) Assessment process should be done with all stakeholders (especially users) to determine what is appropriate for the country/setting,
- b) Integrate with existing national programs and policies,
- c) Provision within an enabling environment (leadership and advocacy for services),
- d) Comprehensive wheelchair service (evaluation, fitting, training, distribution network, repair),
- e) Range of designs to choose from,
- f) What is an appropriate wheelchair? Who defines it (provider, professional, or user)?
- g) The following is a list of elements that need to be evaluated to define an “appropriate wheelchair”:
 - Environment,
 - The functional needs of the individual,
 - Technical capacity of country for repair,
 - Cultural/social appropriateness,
 - Financial capacity of user (target market),
 - Financial capacity of the country,
 - Management of expectations.
- h) Feedback element/follow-up from all stakeholders to evaluate appropriateness; outcome measures.

Syndicate A3 report

Chair: Michiel Steenbeek
Rapporteur: Matt McCambridge

Participants: Bardsley
Borg
Charowa
Curtis
Gallay
Krizack
Lindstrom
McDonald
Mines, R
Nganwa
Radhakrishnan
Seddiq
Sheldon
Winters, G

- 1. Based upon the conference programme, in what areas would you like to see consensus reached? Identify the three areas in which you would consider the priority for consensus to be reached.**

Summary:

- Among diverse strategies for wheelchair provision, we must find commonality. Specifically we must agree on measures of success. "Do no harm".
- Produce an output from this conference that is realistic and relevant to real-world practice. Again, "do no harm" to any existing practice that is effective.
- If possible, definitions of what are an "appropriate" wheelchair and "appropriate" services for a particular situation. Definitions of appropriate service will suggest type of training needed.

Participant comments:

- Commonality and measures of success*
We must agree on "measures of success".
 - A measure of success cannot be merely the fact that a wheelchair was distributed; we need some measure of how quality of life was affected.
 - In what cases is something better than nothing? This can be answered by defining user needs. Basic standards: quality of life improvement by user's own definition.
 - No harm done

Identification of points of commonality among organizations is the top priority.

- Different organizations must try to ensure their activities are complementary not conflicting: what points of commonality exist among differences of strategy/tactics
- One challenge is the varying goals of various local and international parties involved, even within a single project: gestures of international friendship, independence or self-sufficiency of people with disabilities, practical demonstration of religious principles, improving access to development opportunities, good publicity for government, nation, or individual, entrepreneurship and wealth creation.

- Relevance of output to actual practice?*
 - It must be realistic to be relevant. Guidelines for "how you can" not just "you must..." would be useful.

- Education among decision-makers (funders, government) must be improved; this conference should produce a useful output as far as reaching/educating this group; education for organisations, consumers, parents, professionals, governments about wheelchair technology + services needed.
- Wheelchairs are new technologies; good wheelchairs are even newer (last 10 years for third world appropriate wheelchairs); if you do not know something exists, you cannot demand it.
- “Enforceability” of standards? Identify people who will use these outputs to educate/compel governments to be accountable. Governments can be gatekeepers and should be provided with an objective external reference to allow citizens to demand appropriate service. Document must have WHO or similar backing for increased leverage.
- A good example of standards: a government asked for bids for a contract to supply wheelchairs with the local disabled people’s organisation specifying particular requirements/standards; this succeeded due to highly organized local participation.

iii. *Definition of “appropriate”*

- Focus on individuality of physical and occupational needs not needs of donors; a user expressed the opinion that issues of design, such as seating, affordability, and general product quality, are highly relevant.
- Professionals feel that seating is often neglected, especially by people new to the field.
- Seating and support are a top priority and wheelchairs should not be considered as mobility devices only; seating and mobility must be integrated.
- Definition of wheelchair should include seating/postural support
- Need to move away from just distributing wheels, i.e. mobility only without seating.
- Clinical aspects including assessment, fitting and follow-up using prosthetics guidelines as model. Only 20% or fewer users need “standard” wheelchairs.
- Initial assessment is critical to avoid widespread waste. Adaptations to suit abilities/impairments critical

iv. *Other comments*

- Consensus on training and competency standards: through inclusion in therapy education or else stand-alone education, multiple training strategies currently exist.
- Concern was expressed regarding potential drawback of overly “professionalizing” services to the detriment of CBR services which do not conform to professional strategies. User involvement must not be discouraged. Appropriately drafted and conceived system should accommodate all appropriate levels/methods of service provision:
 - Service provision should be “done with” not “done to” disabled people.
 - Unnecessary bottlenecks/gates should be avoided; where they exist they should add to not remove the mechanisms of quality services.
 - Integration with existing CBR structures is critical.

3. What is the current adequacy of wheelchair provision in developing countries?

Summary:

- i. Areas of success: progress and positive trajectories
- ii. Areas of concern: regional inconsistency, NGO involvement
- iii. Necessity of more thorough/objective assessment

Participant Comments:

- i. *Where are we on track?*
 - Technology, both design and production technology (seating not there yet).

- Broader strategies now being employed (local manufacture and international manufacture now integrated)
- International awareness, as indicated by the very existence of this conference
- Disabled people's organizations (DPOs) now involved in wheelchair provision, people with disabilities as experts, noticeable impact on quality of programmes. Some 25 years ago DPOs were unacknowledged by governments, progress has been made and discussions now exist.
- CBR/device integration is on the rise
- Wheelchairs as a development tool, economic empowerment tool are more widely accepted
- Community groups are getting more knowledgeable about wheelchairs; the wheelchair field can benefit greatly from the prosthetics and orthotics work of earlier decades

ii. Areas of concern

- Striking fact; most people have no wheelchair or an inappropriate one;
 - We are meeting tiny fraction of need.
 - No plan to sustainably scale-up provision has been put forward.
 - Sustainability is a major "adequacy" obstacle; the need outlasts the funding
- Great inconsistency of clinical services between nations and within regions:
 - Correlates to inconsistency of government and DPO partnership
 - Follow-up is critical. Comparisons can be made with eyeglasses etc.
 - The whole system strength is linked to local services regardless of origin of product.
 - Multiple strategies have been attempted/documentated in the Republic of South Africa; success tied to integration with appropriate service provision
- Presence of international NGOs in itself is evidence of a problem:
 - The very existence of external interventions is symptom of local lack of services; involvement from outsiders does not always include the use of local resources.
 - Lack of internal funding/structures; outside groups fill in the blanks
 - External wheelchair provision can mask a problem; high-profile involvement of foreign organisation can allow a local government to neglect the problem. There is a duty for international groups to build capacity and network with local DPOs and government despite difficulties/slowness.
 - Local DPOs are the ones who inherit/live with the situation in the country after the NGOs leave; anecdotally local DPO involvement correlates with long term project success.

iii. Better/more follow-up needed

- More objective user quality of life surveys with higher numbers are required to answer this question; failure points could then be identified; testimonials and follow-up research from users as to success stories are also needed.

Syndicate A4 report

Chair: Ritu Ghosh
Rapporteur: Jamie Noon

Participants: Basavraj
Burgos
Deshpande
Feinberg
Hamudenga
Hotchkiss
Mines, K
Nanda, D
Øderod
Reisinger
Seifert
Sovann
Winters, D

1. Based upon the conference programme, in what areas would you like to see consensus reached? Identify the three areas in which you would consider the priority for consensus to be reached.

Four key points were discussed (product, service, training, policy)

Product:

- Agree strength and durability minimums
- Stability on rough terrain, maximum slopes, balance
- Availability of components (parts) in all areas where users live
- Minimum pressure sore prevention (cushions)
- Agree definition for appropriate wheelchair/technology (follow ISPO's definition?)
- Define a minimum consumer information to be provided with a mobility device
- Should there be separate definitions/guidelines for wheelchairs intended for rural vs urban use?

Service:

- A minimum guideline for providing the right wheelchair depending on the users needs (pathology and other factors)
- How to ensure access for poor and rural to service
- How to make services financially sustainable and maintain a minimum level of service
- Agree models for integrated services including support services (therapy, prosthetics, orthotics, social)
- Define conditions under which a wheelchair can be provided safely without an assessment
- Research needed regarding existing related or similar standards or guidelines
- When and how should wheelchair services be integrated with prosthetics and orthotics services?
- Define a minimum consumer information to be provided with a service
- Agree the elements of an appropriate wheelchair service
- Best practice for wheelchair provision
- Agree definition of "do no harm" as part of a minimum for services

Training:

- How to address the need of trained personnel at different levels
- User skills (wheelchair and life skills)
- Guidelines for training personnel in assessment and prescription

Policy:

- Strategies to suggest for government involvement including wheelchair funding, skills development of government personnel, and options to be made available to wheelchair users
- Agree additional language to be included in next draft of UN convention (to include “service”)
- Define role and responsibility of DPOs in effort to lobby governments
- Establish governments role in promoting “do no harm” as a minimum when allocating funding to NGOs.
- Determine who are the most likely governing bodies to endorse and promote the agreed guidelines

3. What is the current adequacy of wheelchair provision in developing countries?

Key points:

- Very few who need wheelchairs get them (2-5%?)
- Majority of wheelchairs provided without assessment and prescription
- Majority receive wheelchairs through “charity model” (camp approach)
- Where there is quantity (camp approach) the service quality is poor and choices are limited
- Where service levels are high (South Africa) charity model wheelchairs can be prescribed appropriately
- Service skills not available in rural areas.
- Service skills not included adequately in professional curriculum.
- Centralised services are generally inaccessible for rural users.
- Donor funding for services is not interlinked with funding for products
- Sometimes a wheelchair is prescribed when an orthosis is more appropriate. Wheelchair can be distributed quickly.
- No national policy available for wheelchair service
- It is hard to financially sustain an appropriate service. No long term funding available.
- Not enough product options for different user groups (children)
- Not enough research into needs of different user groups (children)
- Requirements of products and services are closely linked and in some respects difficult to address separately
- Locally produced wheelchairs are often of poor quality.
- Children’s products and services are not as available as those for adults

Plenary discussion: Syndicates A

Chair: Harold Shangali
Rapporteur: Johan Borg

Introduction

The participants of the conference discussed issues related to the three syndicate questions after Harold Shangali had given a brief summary of the syndicate reports for each question. The discussion showed that the participants agreed with the syndicate findings.

The organisers mentioned that what has been identified in the groups will be addressed later in the conference. This will allow for identification of commonalities to be discussed.

1. Based upon the conference programme, in what areas would you like to see consensus reached? Identify the three areas in which you would consider the priority for consensus to be reached.

Summary of syndicate reports: Areas in which consensus should be reached are the roles of stakeholders, policies, planning of wheelchair services, training of involved personnel, appropriate wheelchairs, assessment, evaluation including measures of success.

The idea of 'do no harm' was mentioned in group reports. It was pointed out that there is a need for defining what we mean by that: Who should decide? How much harm is acceptable to different people?

Wheelchair and service information is not always accessible to all. Information needs to be made available to e.g. people who cannot see, speak or hear. *Information* for all should really mean for ALL.

2. What are the various elements necessary to provide appropriate wheelchairs in developing countries?

Summary of syndicate reports: The various elements necessary to provide appropriate wheelchairs in developing countries are planning, training, service provision, products, information sharing, funding, follow up, and minimum standards for training, services and products.

It was mentioned that WHO has a deep interest in two things that was clearly recommended in the group reports: 1) Minimum standards, and 2) Appropriate wheelchair technology. These two topics were recommended for subsequent syndicates.

The element of *user choice* should be added to the group findings.

3. What is the current adequacy of wheelchair provision in developing countries?

Summary of syndicate reports: The current adequacy of wheelchair provision could be summarised as follows:

Success: awareness, technology, different strategies, integration of assistive devices in CBR.

Concern: limited user awareness, few who need wheelchairs get them, lack of rural services, inconsistency in clinical services, lack of trained personnel, lack of training opportunities, sustainability of wheelchair provision, lack of national funding, funding for services not interlinked with funding for products, lack of national policies, products of poor quality, lack of product options and services (specially for children), lack of research.

Other matters that were raised included:

Empowerment of users and their families

Empowerment of users should be the core of all aspects of wheelchair services. Users can bring the changes. If others rather than the users bring changes, it will be on their terms to meet their interests - not the users'.

Users should be involved in policy issues.

Very few users know about wheelchairs when they come to workshops. Users need to be empowered with skills of advocacy to be able to lobby governments. If users are not involved in lobbying governments there will be little success. Manufacturers will continue to depend on donors. If manufacturers, along with users, are able to lobby governments they may be successful.

To ensure user demand and user choice, users need to know what is available and what exists. Otherwise they do not know what to demand.

Not all users are able to articulate their needs. When a user is part of a family, it is possible to ask for input from them during the provision process. However, often it is not that people with disabilities do not know or cannot express their needs. Instead of encouraging user involvement in the process of provision, service providers discourage user involvement. If users are empowered, the situation will change.

It is important to make informed choices available to the family or the user. There is also a need for a family to respect the abilities of a family member with disabilities - respect that he or she can make his/her own decisions. There are families which do not let go off this role.

When users are involved in the process of provision, they will own the wheelchair more. They will respect the wheelchair and take more care of it. The family needs to be involved, but if the user is not involved personally, he or she may lose the interest in using the wheelchair.

Service providers should take into account wheelchair users with multiple disabilities. Those who cannot speak, hear or see, but require a wheelchair, should be able to make their own choices.

Service provision

The surface is only being scratched; without mainstreaming services into government systems we will not reach very far.

If wheelchair provision is centralised, there should be a practical structure of service provision, who is a player, what should the responsibility be, and what is practically possible at that level.

Activities in Romania and South Africa were mentioned as examples of how small NGOs can get involved in government systems.

As long as there is good networking centralised services should start to be built and then decentralised services, not the other way around. However, it was also mentioned that centralised service can improve the quality, but often there is no effect seen in the community.

Unless CBR is involved in wheelchair provision, we will not reach very far.

A number of questions were raised related to service provision: Who is going to do the training in the countries? Who will do the linkage between people working in different capacities? Lists are created of what activities should be there, but who will implement them? How to change national policies? How to train? How to create mechanisms throughout a country for services? Who will educate government on standards and service delivery? Workshop people do not have time or training to do this. Somebody is missing within the structure. When WHO is developing documents it should suggest who should do what. Disabled people's organisations are good candidates for many of the tasks but they also need

training. In response to these questions, it was mentioned that there has been a number of stakeholders' conferences where these issues have been addressed.

Who does what varies from country to country. The implementers can be completely different. If a separate committee is set up in a country, it will have problem with funding after a few years

In South Africa a policy was developed by a small group, which first became a regional policy and later a national policy. First they set up a system for services before they approached different suppliers in order to let and users have a choice.

It was pointed out that it is not the wheelchair that harms a user, but wrong prescription. It is important to address the health issues related to wheelchair use and non-use.

When considering capacity development it is necessary to remember illiterate caregivers in order to see any progress in users' functional development.

When starting services it is important either to establish national strategies together with other stakeholders or to work in line with existing strategies.

Technical issues

It would be valuable to pooling wheelchair related information together and share it.

There is a need for clarifying the terminology (e.g. appropriate, prescription).

It was suggested that there could be small technical groups working on different topics after the conference.

Syndicates B

Questions: Syndicates B

1. What is the purpose of providing a wheelchair? (Limit discussion to 20 minutes)
(Syndicates B1, B2, B3, B4)
2. What are the necessary elements and required disciplines that make up a successful wheelchair service and what is the involvement of the user in service provision?
(Syndicates B1, B2)
3. What are the different methods of service delivery? Outline the strengths and weaknesses of the different approaches.
(Syndicates B3, B4)

Syndicate B1 report

Chair: Chapal Khasnabis
Rapporteur: Anna Lindstrom

Participants: Armstrong
Bardsley
Burgos
Castellon
Constantine
Ezekiel
Hodge
Khadiri
Madziranzina
McDonald
Ndjambula
Noon
Scheffler
Winter G

1. What is the purpose of providing a wheelchair?

A wheelchair is life for people who need it; it is necessary for life or access to life:

- It is a basic human right.
- It provides mobility to take any further steps; access to education, health care, income and better lifestyle which ultimately contributes to a better quality of life for the individual and the family.
- Promotes greater independence through enhanced mobility and function which also leads to freedom.
- Enhance visibility which helps in greater advocacy and awareness.
- It promotes dignity, self-reliance, inclusion and participation.
- Prevents secondary deformities, reduced health expenditures and avoids premature deaths.
- Economic gain to the individual, family and the country as a whole.

2. What are the necessary elements and required disciplines that make up a successful wheelchair service and what is the involvement of the user in service provision?

Partnership is the key to the success of wheelchair service provision:

- Availability of products
- Knowledge of products including seating
- Knowledge about health issues/conditions
- Funding
- Environmental factors essential to use the wheelchair including advocacy to promote better accessibility.
- Trained staff
- Raw materials and technology to manufacture
- Maintenance
- Skills training for all levels
- Follow-up/evaluation
- A system/structure preferably at government level including a focal person (administrative manager)
- Political support and legislation
- Positive and collaborative attitude amongst stakeholders

Disciplines:

Providing a quality service needs team work which could be comprised of user (including family), wheelchair technologist/technician, physiotherapist, occupational therapist,

orthopaedic technicians etc, but in reality many of these different disciplines may not be available across the country. Considering this, the user and the knowledgeable person who has been trained in wheelchairs and the allied issues are the ones available:

- Users.
- Personal assistants/carers.
- Wheelchair technologists/technicians; training wheelchair technologists/technicians where possible.
- Rehabilitation personnel; training of existing rehabilitation personnel in wheelchair provision could promote a greater access to wheelchairs as in this case government or state does not need to produce a complete new category of professionals.
- Professionals of different levels for creating services at different tiers, e.g. at the national, regional and community level.
 - Skills in marketing and management are necessary.
 - So are also administrative skills.
- Medical staff; access to medical staff for referral/when needed.

Partnership with different stakeholders, e.g. government, NGOs, manufacturers, rehabilitation personnel and user; involvement of government is very essential for inclusion of wheelchair services in national and regional disability, health and rehabilitation policies.

Involvement of the user/family etc in the service provision:

Users and the family members are the major actors in wheelchair service provision which includes advocacy for access, quality service, subsidy and funding. To achieve this, users need to be empowered first; to know more about their own conditions, wheelchairs and its benefits.

- To create the demand for getting wheelchair services and funding for services but to do so; the user needs to know of what exists. Information about the products is important.
- User groups such as Disability Rights Groups or Disability Action Groups can demand for greater access at an affordable cost or no cost for those who really cannot pay any amount. They can also demand a barrier-free environment.
- The user is often the best designer; the user's involvement is a must in designing a wheelchair, ideally it should be a joint effort of the designer and user.
- Participation and involvement in whole process.
- Peer counselling to persons recently injured in hospitals.
- Peer training to other users.
- Problems identification giving the feedback to service providers, manufacturers and policy makers to enhance quality of product and service.
- Self-care to look after themselves especially to prevent pressure sores and secondary complications.
- Self-advocacy leading a dignified life.
- Active participant; role model.
- Sharing information.

Further points for consideration:

- The need a wheelchair; if a good one is available from day one that is fine but, if not, then any kind of wheelchair is fine in the beginning - something is better than nothing
- Define a wheelchair and then an appropriate wheelchair,
- Greater involvement of the parents and family members in the total process of wheelchair service provision
- Charity does not need to be negative; charity has a big role- what is needed is a regular interaction and feedback between donor, service providers and users.
- Twin track approach; on one hand make wheelchair available to the people who are in need (now) and at the same time, pursue the government to allot funding for wheelchair provision.

Syndicate B2 report

Chair: Kim Reisinger
Rapporteur: Fiona Gall

Participants: Cairo
Charowa
Curtis
Deshpande
Gallay
Ispas
Lindsley
McCambridge
Mines, K
Munish
Nanda, R
Schoendorfer
Sovann
Suvapan
Urseau

1. What is the purpose of providing a wheelchair?

Note: Any wheelchair will not necessarily give all these positive results that are listed by the group. An appropriate wheelchair is fundamental to attaining the stated goals.

Mobility:

- First is mobility which leads to other outcomes
- Provide functional mobility and postural support
- To contribute to fulfilling to the right to mobility
- Mobility and self-reliance

Provide access (maximum possibility of access):

- To improve access to school and work
- To enable user access vocational training and social activities
- To enable the user to play and enjoy a life of recreational activities
- Children can go to school, play and be fully integrated into the family
- Provides access to health and other resources available to community members

Equality and human rights:

- To enhance self-esteem dignity and respect
- To improve social skills
- To provide integration of user into society
- It's a human right to have a device
- Social participation
- To improve quality of life
- To promote inclusion
- Promote holistic development
- Promote equality
- Avoid waste of human potential and skill and talent
- Allow community to benefit from the contribution of disabled members
- Poverty reduction is another key issue that mobility can alleviate
- Empowerment of individual users leading to greater no of wheelchair users who can work as a group to lobby for their rights (snowball effect); a role model
- Entrepreneurial Small business

Health:

1. To improve functional skills
2. To avoid secondary complications (deformity)

3. Improve general health and spiritual enlightenment
4. Postural support is integrally linked to provision (better health)

2. What are the necessary elements and required disciplines that make up a successful wheelchair service and what is the involvement of the user in service provision?

Planning:

- Before starting a service we need a clear assessment of user needs and numbers, the environment, the local economic and social situation, issues of sustainability, and the role of government and other stakeholders.
- Different degrees of disability: it is easier to provide services to less disabled which can lead to prioritization for the less disabled. More severely disabled or disabled who live in more inaccessible places have less access.
- The assessment should estimate what is needed in human and financial resources, and what capacities and accountability in the organization starting up.
- The service should be at the lowest, most affordable cost at the highest possible quality.
- Who is the key implementer of the service – this may differ in different countries.
- What is sufficient amount of funding to start services? How do you finance the plan on a long term basis? What about local community expectations. Short term grants of international donors set up programmes and see them fall down after 2 years. Is there a precise sum of funding that should be specified or required minimum?
- National policy on disability should be included in planning.

A referral network:

If we assume that there is a product what are the steps that link this to the user?

- First we have to find the user.
- Identify who may need a wheelchair and what is his/her needs; not everyone may need a wheelchair.
- Different levels of screening; some wheelchair users need very little fitting/training, others are more complex.
- A good referral network will be able to identify and screen the users for the service.
- Need to educate community to understand the use of the different wheelchairs that can be provided.

Within service delivery:

- The group took the national distribution policy in Cambodia as an example and added to it:
 1. General attitudes; define needs and make a treatment plan with user and family according to their environment and occupation
 2. Clinical assessment; what patient has and what patient needs
 3. Therapeutic decisions; prescription and design (and fitting) of wheelchair
 4. Training capabilities; user learns to use wheelchair correctly,
 5. Training of service providers; we need trainers to train staff and train trainers in order to build up exponential network and scale up. Models in other disciplines could be looked at (scuba diving).
 6. Outreach, follow-up and distribution; follow-up of user's health, referral to other appropriate services, follow-up of condition of wheelchair, repair services
 7. Logistics; how to distribute for the service. In accessible places how to solve this. Identification of spare parts; what is the mechanism for this?
 8. Assessment of services; quality control measures of service, basic efficiency and discipline should lead to more economical service.
 9. Costs analysis; funding, resources.

General comments:

- We cannot meet all the needs: How do we prioritize? Identify best case scenarios.
- If we want wheelchair services to be on a professional level we should start from ideal situation and then move up.

Core staff and supporting staff roles:

- If we name groups of professions it can also be restrictive.
- We need to have multidisciplinary teams.
- Users should part of the services (human resources).
- Recognise all the different disciplines involved in a service (users, technical, managerial, distribution etc); build a team.
- Core staff
 - Fitting and assessment (e.g. physiotherapist)
 - Assembly of chairs, repairs (technician)
- Support or consulting staff
 - Surgeon, doctor, medical staff etc who should be accessible.
 - In supporting staff include peer group trainers.
- Management staff
 - Managers and logistic teams and key staff to represent and coordinate with external stakeholders (national staff should be provided capacity to do this)
 - Communication representative or PR rep to report on work and illustrate achievements.

Involvement of the user in the service:

- From beginning to end of planning and running of services users should be included.
- Ownership and investing in the product by the user may lead to a more successful service.
- Some users are first time, some are already experienced. So there are two groups of users who need to be taken into account.
- Education and information material for users: important part of service. Lack of visualization can be difficult and a barrier for potential wheelchair users, sometimes they need to see visually what is possible. They need to see what an active wheelchair user in the community looks like, what they can do. Useful educational visual material for users should be available to give them a better idea of what they can do with the wheelchair. Pictures are good, film better.
- Information can be spread for example through mobile telephone technology which is now is spreading rapidly in many developing countries.
- Communication has various forms; if people do not understand words they can understand images more easily. Audio visual is important method of stimulating the wheelchair user to use his wheelchair better. Follow-up is not as prevalent as we would like so many wheelchair users do not have enough training before they go home.
- Inspirational visual campaigns can have a huge impact on wheelchair users.
- Funders also need to see an impact; how do they see that their money is well-spent? We need to have an information strategy to include them.

Syndicate B3 report

Chair: Marc Krizack
Rapporteur: Hubert Siefert

Participants: Acan
Bayer
Chen Guang
Constantinescu
Dubey
Fang Lizhong
Hamudenga
He Jinming
Ilagan
Mazard
Nanda, D
Semakula
Sheldon
Tardif
Vennila

1. What is the purpose of providing a wheelchair?

Wheelchair as means to a greater end:

- Empowerment
- Human rights
- Political rights; equal participation in decision-making
- Organizing tool
- Access
- Opportunity
- Inclusion

Immediate benefits of a wheelchair (improving quality of life):

- Promote independence
 - Freedom of movement for activities of daily life
 - Access; to school and work
 - Employment and income generation
 - Tricycles and special work/cargo vehicles
- Reduce dependence
 - Provide relief to the family
- Promote physical and psychological health
 - Good posture and comfort to increase functionality and health
 - Increase dignity and self-esteem
 - Reduce social stigma and overcome traditional beliefs
 - Self-confidence for the user
 - For children
 - Normal physical growth
 - Participation in play activities
 - Social interaction and appropriate education
 - Allow the mother to be near to her child
- Stakeholders
 - Manufacturers: transfer of technical know-how (to improve the QOL of the user)
 - Government: Facilitates government programmes
 - Caring for disabled people including the elderly
 - Support in disaster management/first aid

“To push the development of society and share in the progress of civilization”

3. What are the different methods of service delivery? Outline the strengths and weaknesses of the different approaches.

	Strengths	Weaknesses
Direct purchase from retailer/ internet	<ul style="list-style-type: none"> • Fast and easy • More attention can be paid to user if from local retailer • Spare parts available if from local store 	<ul style="list-style-type: none"> • Need for purchaser to have a lot of knowledge. • Decision often made by the family • No adequate or appropriate clinical input • Need money to access service • Commercial service may be more interested in profit than service
Local production	<ul style="list-style-type: none"> • Easier to get follow-up service • Easier to get repairs • Provides local jobs often for PWD 	<ul style="list-style-type: none"> • May be difficult finding qualified local service professionals • Largely donor dependent
Local production (mass)	<ul style="list-style-type: none"> • Can offer many different models at lower cost • Quality usually more uniform and potentially higher 	<ul style="list-style-type: none"> • Less likely to offer customization than small scale local production • Requires more chairs be sold to be sustainable •
Local production (small scale)	<ul style="list-style-type: none"> • Design can usually be more adapted to local conditions • Greater possibilities for customization and best fit 	<ul style="list-style-type: none"> • Limited number of people who can be served • Higher costs make it more difficult to sell chairs
Service delivery through rehabilitation centres	<ul style="list-style-type: none"> • Funding may be available to pay for service • More comprehensive services • Provided by professionals • Multidisciplinary approach • Opportunities for professional development • Potential for government involvement • More user focused because users present 	<ul style="list-style-type: none"> • Donor dependence • Maybe too much a medical approach • Centralized service far from rural areas – may be more costly for users if no collaborating CBR or community- level services programme • Potential for government involvement
Mass distribution without professional services (usually imported wheelchairs)	<ul style="list-style-type: none"> • More people served at lower cost • Usually higher quality for similar product; often look better • Local ceremonies bring attention 	<ul style="list-style-type: none"> • less access to repair parts • Unsustainable – wheelchairs break down • could limit development of local and sustainable efforts • Little direct feedback from users • Little or no follow-up • Focus on mobility aspect not the other aspects • Promotes negative image of PWD • Less opportunity for linkages with DPOs and general networks • Competes with local business and jobs
Mass distribution with professional services	<ul style="list-style-type: none"> • High volume, low cost, individual attention: The best of all possible worlds 	

Note: Highlighted items can be both Strengths and Weaknesses

Syndicate B4 report

Chair: Lloyd Feinberg
Rapporteur: Ray Mines

Participants: Basavraju
Borg
Cornick
Ghosh
Hotchkiss
Lyimo
Mukwasa
Nganwa
Pearlman
Seddiq
Shangali
Steenbeek
Umarshankar
Winters, D

1. What is the purpose of providing a wheelchair?

There was some discussion around what the question was actually trying to address. However, the following is the list that was generated during discussion:

- To give full and adequate mobility for going to school, employment, family
- Mobility to access rights and enjoy life
- Is the aim of a wheelchair to get people off the floor or more than that?
- Preventing complications
- Lots of different purposes
- To go wherever you want to go, whenever you want to do it (dependability)
- What does adequate mean?
- Hospital vs dependability is not necessarily a valid distinction, older models of chair which are dependable, in the details not in the type, happens that generic ones are made cheaper, standards of dependability, ranges of qualities of components
- Postural support? Included in definition of wheelchair?
- To give postural support and mobility
- A good chair can prevent scoliosis
- QOL for user and family
- Promoting health, preventing complications
- What's the definition of a wheelchair? Does it include postural support or not?
- Can we consider postural support integral? Are we that far advanced?
- A good wheelchair may already include features that facilitate postural support/or make it harder!
- Facilitating sports features
- Suitable wheelchairs provide dignified mobility
- Dignified means independent to some and pusher friendly to others
- Suitable, appropriate
- Mobility, rights. Where trained professionals are not available - wheelchairs are given in place of other unavailable devices
- Hospital use and short term use
- Safe mobility
- To give safe, full and adequate mobility to access rights, enjoy life, QOL
- Safe options for providing mobility, independence, improving health, avoiding complications
- To provide a safe option for optimum mobility with which to improve QOL, improved health and increased accessibility to social, educational, economic and political inclusion/participation

3. What are the different methods of wheelchair service delivery?

Methods of wheelchair service delivery listed by the group:

- Camps
- Distribution model (with professionals)
- Distribution model (without professionals)
- Events/ceremonies
- Wheelchair workshops
- Wheelchair services
- Hospital based team delivery approach
- Community based
- Through NGOs and DPOs
- Commercial retail
- Outreach

It was noted that this is not a comprehensive list of all methods of service delivery due to the short time available. Although not all of the methods were discussed in detail, outreach services and mass donations were and below are summaries of the two discussions:

The group felt that the various methods of large scale wheelchair service delivery share common strengths and weaknesses. The major strength is the number of wheelchairs it is possible to deliver to users in a short space of time with little extra resources. Also the wheelchairs are provided free to the user.

The major criticism of this approach is that trained professionals are not involved, and that it is therefore quite random whether the single choice of product suits the users' needs. If large scale donation is coordinated with local organisations/service providers it would increase the opportunities for the user to choose the wheelchair that most suits them. Mass donation can have the negative side effect of flooding local markets with free products, making it very difficult for local producers to compete. Mass donated products are also criticised for generally not being durable in the demanding environments found in developing countries and not meeting the individual requirements of the users.

Outreach services are run by organisations or institutions by 'reaching out' from centralised services. This method relies on the establishment of central services first before outreach is possible. The advantages of this method are that trained professionals staff the service, it involves less travelling for the user and their family by supporting them in their own locality and it means that you don't need to establish services in every community.

The drawbacks of outreach style services are that they potentially take resources away from the central services, the local areas receive only periodic services and therefore there is less access to repair and follow-up than completely community based services.

Discussion points:

- Monopoly vs competition. Level playing field allows competition. Raises standards in whole market. Users choosing chairs from range. Services that facilitate user choice. Addressing government tender systems.
- Users depend on donations. Users do not always purchase wheelchairs directly. Donors purchase wheelchairs. Why would someone buy a chair when one can get a free one? Mass donation of inappropriate wheelchairs flood market and make it difficult to sell local made. Lobbying major purchasers.
- Discussed purchasing practises by governments including the US.
- All models can be done by government, NGOs, INGOs, private commercial, etc.

General statements:

- Many various factors that add up to strengths/challenges of all models.
- Challenge with all models is to have enough trained professionals. Increase the multi-disciplinary/skills approach: clinical, technical and user.
- Raise standards of products across all models.
- Increase the number of users who receive wheelchairs appropriate to their needs

Plenary discussion: Syndicates B

Chair: Christine Cornick
Rapporteur: Jon Pearlman

1. What is the purpose of providing a wheelchair?

Gall: Syndicate B1 made the general comment 'any type of wheelchair is better than nothing'. Other syndicates do not agree; there is a need for an 'appropriate wheelchair'.

General discussion:

- Syndicate B2 said mobility would be first important factor to wheelchair provision which implied that users are active users. This may not be the case for all user groups.
- Syndicate B1 noted down every comment, so all points may not be the consensus of the group.
- It was commented that wheelchairs provide both mobility and postural support so mobility may not be the primary factor.
- There was disagreement that 'any' wheelchair is better than nothing. Maybe it should be reworded that a 'basic' wheelchair is better than nothing.

Hotchkiss: It is not better that any wheelchair is better than nothing. Many wheelchairs are being provided that are nowhere near as good as they should be. It is embarrassing that such poor wheelchairs are being distributed. No fitting; children in huge chairs. Millions of dollars go into it and scoliosis or pressure sores occur.

General discussion: It was felt that terrible deformities occur by providing poor fitting wheelchair.

Khasnabis: Reality is different. In Kenya, for road traffic injuries, one has to wait 3-6 months for hospital admission and 6-12 months to be healed. If there is no wheelchair people will remain in hospital forever. In that case, any wheelchair is better than nothing so people can get out of hospital.

Curtis: There is no black or white answer. Considering all the postural issues and other factors that are important one has to wonder if by giving 'any chair' people are being responsible about taking care of other issues. It is a false choice, must say what you are doing to address all these issues. If you disregard several of them then you are not really fulfilling the disabled person's needs. Is it better than nothing? 'Maybe', but we have the responsibility to address other issues.

Acan: We are here to solve other problems. We are here to decide what the right chair for use in developing countries is. I would not use 'just any wheelchair'; it may make life more difficult. We should not talk about no wheelchair or a wheelchair; we should focus on what type of wheelchair is appropriate.

Ilgan: Highlight the need for education of users. They do not know what a good wheelchair is. Need to know what the criteria are. Information is rarely known. Users think that if it is from industrial countries it is good, but that is not always the case - users need to learn that also.

Sheldon: 'Is any wheelchair better than none?' We have responsibility to use our resources efficiently. Refer to the Cooper presentation on ISO testing - it is a false economy to think that providing cheap wheelchairs is actually efficient. Look at cost in terms of durability.

General discussion:

- What is the 'other choice'? Parents put their children on a carriage or wheelbarrow, they think it is absolutely better that 'some' wheelchair is better than none. However, we are aware that a proper wheelchair is best.
- There is also the matter of secondary injury. A quality wheelchair is needed for everyone in order to avoid secondary injuries.
- There are some clinical figures on secondary injuries. The CP group 80 - 90% have secondary problems. Amongst the spinal cord injured about 10% develop postural deformities in rehabilitation. It is our responsibility to provide proper fitting wheelchairs. Need to ensure people are initially fitted well to avoid postural issues.

Cornick: We can agree that 50% of chairs we distributed are failures, why not spend the money to ensure that wheelchairs provided do not fail.

2. What are the necessary elements and required disciplines that make up a successful wheelchair service and what is the involvement of the user in service provision?

&

3. What are the different methods of service delivery? Outline the strengths and weaknesses of the different approaches.

Lindstrom: Concerning UN convention not mentioning 'services' in their text: people involved in document have had trouble putting 'assistive devices' language into text. The current draft will probably go to the UN. It has been difficult to get through to chairperson about correcting terminology; they never know when things such as 'services' will get into the convention. These standard rules will be more a more detailed document to promote appropriate devices.

Cornick: What is role of user in service provision and involvement?

Gall: coming from the medical approach, I have learned a lot from wheelchair folk, and these types of discussions. ISPO needs to take into account that service models may need to be changed and that we need to make progress toward a social model. I hope that the guidelines will emphasize the social model.

Noon: The role of user needs to be emphasised. As a service provider I find that if the user is not involved in the provision process, the outcomes are much different. Highlighting the users' role is not just empowering them; it is necessary to get a better result.

McDonald: I am bothered by comment about 'moving forward'; certainly things will still be done incorrectly but our goals here are to make things change rapidly.

Constantine: We are back to the issue of responsibility of organizations. There is emphasis on the need for finding partners to address other issues of provision and quality of life.

Horvath: With regards the need for 20-30 million wheelchairs, the need is so great that we cannot think that large-scale production should not be part of the equation. Need to find a way to have all the elements contributing to global solutions.

Cornick: In summary, there is a need to look at numbers and different approaches, but also a need to focus on developing the different services to work together and focus on working partnerships so broader scale models are complementary to local solutions.

Hodge: With regards Syndicate B3's comments that mass distributions promote a negative image; this has been found to be the opposite in many situations where mass distribution has formed peer bonds between people with disabilities. Also working with government officials helps to educate them.

Seifert: The negative image is due to idea of 'charity'. Wheelchairs are looked upon as handouts. It does not empower people with disabilities but degrades them.

Curtis: Issue is that donated chairs give users the entitlement idea as users of free products. Discussion needs to be about how local production can be done in many places.

Khasnabis: The need is so huge that there is space for everybody. Wheelchair provision is a development issue and it will evolve in time. WHO has a big department in traditional medicine, in many countries that that is the only way it works. So WHO helps them out—point is not to turn away to them but to include them and train them.

Hodge: How many people here have attended a mass distribution? (*About 50% of participants indicated that they had*).

Shangali: For a successful mass distribution it should be done through the services available in that country. The issue arises when it is not integrated through the national health system.

Acan: I agree with Shangali. Mass distribution is OK, and wheelchairs are OK for some. One issue is that sometimes distribution is used for political campaigning. People do not know what wheelchairs are best, so education needs to be done.

Mines: Need to talk more about how mass produced wheelchairs fit the individuals' requirements. Issue is to work together to make sure wheelchairs are delivered through wheelchair services.

General discussion: Giving a wheelchair is not enough: wheelchairs need to be adapted in some cases. In some cases there is a need for occupational therapists or technical people. Issue is that these trained individuals do not exist. It is a call to the north to develop these specialties in the south. People in the south do not know about 'postural deformities'; there is a need for training in this topic.

McCambridge: With regards the scale of need: if you give away 20 million wheelchairs and 1 million work or if you give away 100 million wheelchairs and none work, then you have not dealt with scale. Small scale wheelchair production also does not deal with the overall need.

Syndicates C

Questions: Syndicates C

1. Based on the following modified ISO definition of a wheelchair:

“a device to provide wheeled mobility with a seating support system for a person with a walking limitation”

define the term “Appropriate Wheelchair”.

(Syndicates C1, C2, C3, C4)

2. What factors need to be taken into consideration when designing wheelchairs to be used in developing countries?

(Syndicates C1, C2)

3. Discuss and outline the importance of cushions and postural support as part of a wheelchair.

(Syndicates C3, C4)

Syndicate C1 report

Chair: Kylie Mines
Rapporteur: Johan Borg

Participants: Cairo
Curtis
Dubey
Ezekiel
Feinberg
Ghosh
Hodge
Krizack
Munish
Nanda, D
Pearlman
Reisinger
Seifert
Semakula
Umarshankar
Winters, D

1. Based on the following modified ISO definition of a wheelchair:

“a device to provide wheeled mobility with a seating support system for a person with a walking limitation”

define the term “Appropriate Wheelchair”.

Difficulties with coming up with a single definition:

- A definition as such could be too limiting and that what was needed was a list of key elements or points.
- Need to define: appropriate for who, and in what context
- Needs to be a range of appropriate wheelchairs

Key points (bearing in mind that ‘wheelchair’ has already been defined):

- Improves quality of life
- Is safe; does no harm
- Mechanically sound
- Cost effective: affordable, longevity, cost of repair/maintenance
- Meets user needs (mobility, physical, life goals, social etc.) therefore a range of wheelchair models
- Repairable
- Meets the environmental and contextual conditions
- Durability and longevity

Other factors:

- Improves accessibility
- Empowers the user
- Biomechanically sound (pushing, seating support, safety)
- Promote good health
- Easily usable by the user
- Min complexity, cost, weight
- Maximum durability, mobility for individual, comfort, repairability, aesthetics, safety (graphically)
- Marketable (attractive design, attractive to donors)
- Perceived as modern
- Inappropriate:
 - Longevity less than 1 year (not fully resolved in discussion)
 - A high-tech wheelchair is not automatically appropriate

General comments:

- To ensure appropriateness one needs to consider the way in which the wheelchair is supplied, e.g. process of service provision.
- Minimum standards are required.
- A tool to measure appropriateness was suggested where the characteristics of a wheelchair is scored against different indicators of appropriateness.
- There was discussion about whether it was possible to categorise wheelchairs – and develop lists of what is appropriate for different categories, e.g. ‘temporary’ (‘first aid’, ‘initial’) and ‘permanent’ wheelchairs.
- Can there be a single wheelchair that is appropriate? Or should there be multiple options? There should be as many options as possible to suit individual needs.
- What does affordable mean? Depends on user’s resources.

We need to look at parallel usages of wheelchairs; some need an immediate wheelchair to get started, others need wheelchairs with longer lifetime. Temporary wheelchairs may be appropriate in some instances. Everyone wants an appropriate wheelchair. It was suggested that the term ‘temporary wheelchair’ might be usable to overcome controversies between different approaches. What is the difference between permanent and temporary wheelchair? Does it reduce the responsibility? Irrespective of type of there should be no compromise with wheelchair standards. A comparison with prostheses was given; there is no such thing as a “first aid” prosthesis.

2. What factors need to be taken into consideration when designing wheelchairs to be used in developing countries?

User:

- User profiles:
 - Seating and postural needs
 - Activities (ADL)
 - Child/adult
 - Intended use
 - Types of disabilities
- Distance
- Transferring
- Economic situation
- Safety

Context:

- Local environment
- Locally available materials and components
- Availability of public transport
- Need for bringing wheelchair in public transport/taxi etc.
- Use in narrow spaces
- Culture (may affect colour, seat height, etc.)
- Climate

Production:

- Locally available technology (production method)
- Management of production unit
- Technical know-how
- Capacity of producer
- Sustainability/funding of producer
- Commonly available parts/components

Product:

- Repairability
- Simplicity
- Maintenance

- Aesthetics
- Weight

Others:

- Service infrastructure
- Marketability (considering both the buyer and the purchaser)

Recommendation:

- To review general definitions of appropriate technology and see how to apply them in the field of wheelchairs.

It was noted that necessary compromises may take the designer far from the ideal wheelchair design. The user should prioritise the importance of design factors.

Syndicate C2 report

Chair: Elsjé Scheffler
Rapporteur: Bill Armstrong

Participants: Castellon
Constantine
Constantinescu
Hamudenga
Heim
Hotchkiss
Ilagan
Khasnabis
McCambridge
Mines, R
Mukwasa
Ndjambula
Schoendorfer
Seddiq
Steenbeek
Tardif

1. Based on the following modified ISO definition of a wheelchair:

“a device to provide wheeled mobility with a seating support system for a person with a walking limitation”

define the term “Appropriate Wheelchair”.

Consideration given to ISPO definition for prosthetic devices:

“A system providing fit and alignment which suites the needs of the individual and can be sustained by the country at the most economical price. Proper fit and alignment should be based on sound biomechanical principle.”

Some discussion points:

- General adjustability in wheelchair design.
- Capability for specific adjustability and modification
- Fitting process and application responsibility of provider

Proposal:

An appropriate wheelchair is defined as one that is available, accessible and durable, that meets the individual’s need and environmental conditions, with proper fit and postural support, that can be sustained by the country at the most economical and affordable price.

2. What factors need to be taken into consideration when designing wheelchairs to be used in developing countries?

User issues:

- Type of disabilities
- Cultural factors
- User preferences
- Aesthetics/colour
- Target group

Financial considerations:

- Life Cycle Cost

Technical:

- Available technology
- Availability of materials
- Type of materials
- Manufacturability
- Durability
- Reliability
- Safety
- Effect on environment

Performance:

- Weight
- Size

Environmental:

- Environment
- Weather Conditions
- Rust resistance
- Transportability
- Access to floor
- Access to everything
- Social behaviour
- Cultural Environment

Service:

- Distribution
- Wheelchair Service

Syndicate C3 report

Chair: Geoff Bardsley
Rapporteur: Cristian Ispas

Participants: Acan
Basavraju
Charowa
Chen Guang
Deshpande
Fang Lizhong
He Jimming
Khadiri
Lindsley
Lyimo
Nanda, R
Noon
Øderod
Shangali
Sheldon

1. Based on the following modified ISO definition of a wheelchair:

“a device to provide wheeled mobility with a seating support system for a person with a walking limitation”

define the term “Appropriate Wheelchair”.

“An appropriate wheelchair is one that meets individual needs which include individual clinical and functional requirements, postural seating requirements, adapted to the local environment; it is safe, and locally affordable.”

An appropriate wheelchair should take the following into account:

- meets individual postural seating requirements/adaptability should be considered for initial fitting and longer term changes in need
- meet individual functional requirements:
 - transportation (foldable if required)
 - propulsion and manoeuvrability by the user
 - manipulation by the assistant
 - ease and intuitive nature of usage
 - methods of transfer from/to the wheelchair seat
- appropriate to the local environment
 - durability (need to consider a life expectancy target, e.g. 5 years)
 - terrain (mud, rough ground, grass, pavement)
 - stability (negotiate curbs and ramps)
 - suitable for local accessibility (doorways, ramps, lifts) note: overall dimensions are significant
- locally affordable
- light in weight
- good appearance/aesthetics
- locally maintainable/spare parts available/made with appropriate raw materials

Note: Need choice of wheelchairs (no one wheelchair meets everyone needs)

3. Discuss and outline the importance of cushions and postural support as part of a wheelchair.

“Wheels don't kill”

- In designing a wheelchair, the body support system is of equal importance to the mobility aspect.
- Cushions and postural support can prevent pressure sores.
- Within wheelchairs, cushions and postural support can prevent, accommodate and correct deformities:
 - Inadequate postural support produces poor postures which can become fixed deformities leading to medical problems (e.g. respiration), limit the functional ability of the person (e.g. visual field, eating, communication, and propelling the wheelchair), increase the complexity of subsequent seating, require more care, and medical treatment.
 - Postural support is any part of any wheelchair which supports the body – can be as simple as a seat and backrest or a very complex system which supports total body (need to develop a definition of postural support).
- It is important to match the cushion to the individual need (no agreement on possible requirement that all wheelchairs should have cushions).
- Cushions and postural support affect comfort/sitting tolerance (to be defined).
- Cushions and postural support reduce fatigue from sitting over long periods of time.

Syndicate C4 report

Chair: Rob Horvath
Rapporteur: Jean- François Gallay

Participants: Bayer
Burgos
Cornick
Gall
Lindstrom
Madziranzina
Mazard
McDonald
Nganwa
Radhakrishnan
Sovann
Suvapan
Urseau
Vennila
Winters G

1. Based on the following modified ISO definition of a wheelchair:

“a device to provide wheeled mobility with a seating support system for a person with a walking limitation”

define the term “Appropriate Wheelchair”.

Focused on the word "appropriate"

- correct fit
- used in rough terrain
- compulsory cushion
- design appropriate to living environment
- customised
- comfortable
- lightweight
- locally repairable
- technology
- materials
- affordable
- best quality for lowest cost
- safe
- adaptable
- durable, lasting
- cost effective
- adaptable/adjustable features
- prevent secondary complications
- meets the users need
- provide optimum mobility
- adapted to different climates
- choice

Definition modified "appropriate technology" consensus:

“An appropriate wheelchair is an assistive (mobility) device providing proper fit and alignment based on sound biomechanical principles which suits the needs of the individual, their environment and can be provided and maintained in the country at the most economical and affordable price.”

3. Discuss and outline the importance of cushions and postural support as part of a wheelchair

It was felt that cushions and postural support are different components.

Pressure relief cushions and 'basic' postural support must be integral to all wheelchairs.

We tried to define what postural support means.

Basic postural support should facilitate proper fit and alignment on sound biomechanical principles for:

- comfort
- good positioning
- safety
- to avoid secondary complications
- to increase physical functions
- good posture helps increases self esteem
- life saving

Postural supports have to be adjusted according to user needs/pathology and wheelchair designs should allow postural support adjustments.

Plenary discussion: Syndicates C

Chair: Claude Tardif
Rapporteur: Sarah Sheldon

- 1. Based on the following modified ISO definition of a wheelchair:**
“a device to provide wheeled mobility with a seating support system for a person with a walking limitation”
define the term “Appropriate Wheelchair”.

There are substantial similarities between all syndicate definitions of appropriate wheelchairs.

A discussion was held regarding the definition of ‘sound biomechanical principles’.

Should we be using words such as ‘fit’ or ‘fit according to seating principles’? Is there a generally accepted standard regarding fitting of wheelchairs; has there been published research?

Defining right fit is very difficult as people have different needs.

It was clarified that ‘biomechanical fit’ is known terminology meaning a stable position of the spine when the joints are in the most mechanically stable position; it is also known as neutral posture.

It was agreed ‘alignment’ should not be in the definition, as not everyone is fully comfortable like that and some people cannot achieve alignment. It was noted that alignment in some cases can inhibit function, and some people prefer to sit in a different position to increase function.

The reference to normal alignment is important as a lot of wheelchairs do not allow for seating in a normal alignment and if you cannot achieve this in the beginning with a new injury there will be problems later.

Biomechanical is a good word – cushions have very sound biomechanical principles – mechanics applied to the body.

A seating system is a biomechanical system. Also where the wheels are located and how the user interacts with the wheelchair is very important

Affordability should be removed from the definition as it might conflict with appropriate posture; it should be considered under Question 2. Affordability is in contradiction with appropriateness. Appropriate should be gold standard.

It is not necessarily expensive to have a good postural support wheelchair. A wheelchair causing harm might need minimal input to make it appropriate. A postural support wheelchair should be affordable.

A question was raised regarding the definition of affordable and whether ‘lowest possible price’ would be more appropriate; however, it was noted that ‘lowest possible price’ does not necessarily result in the best quality. Going for low price can lower quality, e.g. Sri Lankan example.

Substitute cost-effective for affordability.

This is a political statement and will apply to those who pay for wheelchairs. It must be understood that affordable is wider than lowest possible price.

Agreement with cost-effectiveness. However, affordable and cost-effectiveness are different.

The UN convention uses 'affordable' so the consensus should use the same terminology.

2. What factors need to be taken into consideration when designing wheelchairs to be used in developing countries?

There should be a partnership between user and designer to prioritise design factors.

Also clinicians should advise on design factors.

The needs of women who are using wheelchairs and have to carry babies should be considered.

Wheelchair can also be used to transport goods.

The needs of those who do not need a wheelchair by prescription should be considered, e.g. those that just need a wheelchair to travel to school, but in school use crutches.

3. Discuss and outline the importance of cushions and postural support as part of a wheelchair.

Concern was expressed how wheelchair can be seen as life saving. Life saving is not the phrase to use.

Disagreement was voiced and it was suggested that pressure relief cushions should be integral to all wheelchairs.

Cushions and postural support are different components – do not agree that they are integral parts of wheelchairs.

While there are many people who do not require a wheelchair cushion everyone who has to sit permanently in a wheelchair will benefit from a cushion; the moment a pressure sore begins the road to dependence and ultimately death has started. Also there is potential cost to the health service.

The South African government changed their minds as soon as they realised how much money they were spending on pressure sore care.

Cushions may not be provided in every case, but peoples circumstances may change and it is better a cushion is provided from the onset.

Without a cushion one would have to have the seat adjusted to get the pelvis locking system in place. The cheapest way is to add a cushion.

Idea that people need wheelchairs in an emergency is damaging. This is not about an emergency situation that needs to be addressed with vast numbers of wheelchairs this is about independent living and quality of life.

There are minimum standards in Uganda and it was deliberated whether a cushion should be included in a wheelchair. It was agreed that a basic cushion should be included. The question arises; what is basic? There is a need to agree what is basic.

If we do not say a wheelchair should have a cushion then there will not be a possibility of governments providing them.

If you have one choice then you should put a pressure relief cushion on a wheelchair. Even someone with sensation can develop a pressure sore.

We should not let the issue of cost take over as there will come a time when wheelchair users share the costs their chairs.

A wheelchair can be designed to facilitate postural support and conversely a poor design can cause postural problems.

Syndicates D

Questions: Syndicates D

1. Is it better to deliver any wheelchair than no chair at all? If so, in what situations?
(Syndicates D1, D3)
2. Using the report of Syndicate B3 as a starting point finalise the table of strengths and weaknesses of different methods of wheelchair provision using the report of Syndicate B4 and the plenary discussions to date.
(Syndicates D2)
3. Using the presentation of Ray Mines as a starting point, develop a table of strength and weaknesses of different production methods.
(Syndicates D4)

Syndicate D1 report

Chair: Fredrick Semakula

Rapporteur: Kim Reisinger

Participants: Acan
Borg
Chen Guang
Cornick
Fang Lizhong
Gallay
He Jinming
Hotchkiss
Khasnabis
Madziranzina
Mines, K
Ndjambula
Radhakrishnan
Shangali
Steenbeek

1. Is it better to deliver any wheelchair than no chair at all? If so, in what situations?

Yes	Sometimes it is
Yes	If it provides basic mobility
Yes	If person has no disability, is using it temporarily, and using indoors
No	Not if its not safe and could do harm
No	Not if it doesn't meet minimum standards
No	Not if it doesn't meet individual requirements

Concern with term “any wheelchair” allows people to make a decision about what “any” means

Clarify what is meant by “any wheelchair”:

- appropriate wheelchair = delivered and fitted in appropriate way
- need wheelchair that meets individual needs – such a wheelchair should be accepted
- meeting individual needs leads to appropriate.

How powerful are we to say no? We cannot forcefully do anything in a country – the need should drive the solution – must have minimum standards:

- **Need minimum standards for distribution effort** – add few more individuals to distribution team
- **Need minimum standards for service provision** – including mass distribution
- **Need minimum standards for wheelchair** – should there be different standards depending on conditions of use (e.g. indoor/outdoor, active, etc). Many chronic conditions need long-term care, but identify more common ones and try to address those.

If wheelchairs are considered to be medical goods they should be distributed through a controlled effort; wheelchairs seem to be an exception to controls.

If wheelchairs are distributed via mass distribution, they should be given away under minimum standards.

Integration of wheelchair services within existing health service system in country. In countries where health systems do not exist, other (e.g. private) distribution can occur, but should have possibility of scaling up.

Even if wheelchairs are not completely appropriate, they can be used in other locations (e.g. hospitals).

Advantage of unregulated distribution is that some very poor people obtain wheelchairs that they might not get through health system.

Concern with going into country starting small and hoping that it grows (Government will take over).

Mass distribution should be discouraged when it is not combined with existing systems.

Two final answers:

Yes, where the wheelchair meets the minimum product and service standards in that situation. In situations where wheelchairs and services are not meeting minimum standards, greater collaboration between stakeholders could be used to support and encourage improvements in the product and/or service to meet the standards.

No, a wheelchair should meet minimum product and service standards in any situation. However, in situations where wheelchairs and services are not meeting minimum standards, greater collaboration between stakeholders could be used to support and encourage improvements in the product and/or service to meet the standards.

Syndicate D2 report

Chair: J Steen Jensen
Rapporteur: Fiona Gall

Participants: Armstrong
Burgos
Charowa
Deshpande
Ezekiel
Heim
Ilagan
Krizack
Lindstrom
Mazard
Munish
Nganwa
Scheffler
Sheldon
Suvapan
Vennila

2. What are the strengths and weaknesses of different methods of wheelchair provision?

Wheelchair provision in a small community based workshop

Strengths

Good **quality**, individually made for each client.
Small amount of production can mean quality can be controlled and checked out quality.
Use local material and simple technology.
Appropriate wheelchairs for the local area.
Easier to take into consideration local environment factors.

Access - easier to make modifications when the workshop is close to the client and feedback is more possible.

Access for children is easier – because of proximity.
Small workshop can provide on-going service to their consumers.
Efficiency - if something needs repair the workshop can do this quickly.

Sustainability of the workshop is easier because of lower production.
Employment possibilities for the wheelchair users in the area.
Sense of ownership in the local community of the workshop. Users can get their wheelchairs repaired and give feedback to the service.
Can be cost effective, e.g. can promote local artisans to repair and maintain appliances.
Skills are transferred to local community.
Smallness can mean it is easier to sustain (less overhead costs) and meets local needs.

Challenges

Quality of finish of product can often be poor.
Small workshops cannot compete with bigger workshops in quality and quantity.
Compromise of quality due to lack of appropriate materials
Limited access to improved technology which may increase costs or affect quality of wheelchairs.
Referral network may be difficult to put in place to refer complicated cases
Long waiting list of wheelchair users
Lack of availability of materials and supplies
Small quantities of materials can mean higher costs

Cannot always meet the need (number of wheelchair users)/ sometimes not enough clients
Difficult to obtain professional input for complex cases
Lack of professional/technical support to improve service
Small workshop may have a limited range of products and cannot offer the user what he/she needs.
Some factors that affect quality – recruitment, competition, demand – can be the case for any size workshop.

Recruitment and retention of qualified staff in rural areas can be difficult.
Minimally trained people can lead to low quality work, wastage of materials.
Staff may not have clinical skills required
Small workshops with 2 technicians may not be able to cope with some pathologies due to lack of training and if they are not attached to rehabilitation centres or hospitals.
Isolated workshops may not be able to meet the needs of rare pathologies

Long-term sustainability is a challenge
Irregular orders may mean no work and no funds.
Less able to lobby and pressurize political actors for funding.
Lack of communications capacity to publicize the work (due to funds or lack of human resources)
Difficult to find funds from government or other sources if the workshop is run by local NGOs or DPOs

Within health care policy and legislation of govt small workshops may not be able to tender to government and thus supply their customers. In South Africa small workshops can only tender to private market.

What is a small workshop?

In production terms: category of up to 50 wheelchairs produced a month.
1 technician can make 4-5 wheelchairs a month = 10 technicians make 50 a month
Or 4 person days = 1 wheelchair (from scratch) or 1 per day (flat-packed)
However, staff may have several roles – adjustments for individual chairs, assessment etc?

Actual situation – no uniform model

Small workshops have grown up with an individual or a group of disabled people making wheelchairs, starting up in places where there are no services. They may lack training and clinical skills.
This not necessarily a viable economic model but has come of need and the different situations in different countries leading to workshops with different functions.
What services can be incorporated into a small workshop or added such as the ability to assemble flat packed models for distribution?

Hospital based/rehabilitation centre workshops – Government/NGO – small to medium

Advantages

Workshop can be more specialised in terms of primary function because there are other specialists available for clinical services including assessment, prescription and training of user.
User can access wheelchair services more easily in one centre – one stop shop.
Complicated cases can be more easily helped.

Easier to raise funds for poor wheelchair users being part of the health system.
Workshop can benefit from overhead support costs (electricity, salaries).
Workshop staff can benefit from multi disciplinary approach – other skilled staff available.

Challenges

To become part of hospital/medical services means less ownership by wheelchair users.

It can affect funding because government does not always prioritize workshop services. If the workshop is attached to a health centre/hospital it can end up being low priority for funding.

INGO workshops – no single model, adapted to the different philosophies of each NGO. NGOs may have a particular expertise but do not always create models that are sustainable in each country.

Can NGO can be viewed as a private unit economically or as a unit attached to a health care system.

Difficult to hand over to national partners. Workshop may not find continued funding.

Best practice guidelines

Wheelchair provision services before starting up need to first plan by assessing needs and consult all stakeholders at different levels to ensure appropriate service delivery and long-term sustainability.

Mass distribution

Camp approach.

Quick one day distribution can put pressure on good result. Time should be allowed for fitting and customising.

If we can pre-assess and list the users and manage a database so that when there is a mass distribution this can be effective.

There needs to be a team of skilled professionals (nurses, physiotherapists, OT, doctors etc) to modify and adjust on the spot.

In many mass distributions there is lack of choice of types of wheelchairs for different types of users.

Ceremonies complicate quality of service – can these be held separately from fitting?

Responsibility of donor to tell recipient what must be done for a good quality distribution.

National government also has responsibility to ensure properly managed distribution.

User should be allowed to choose if he/she prefers mass distribution or through health service/local workshop.

Syndicate D3 report

Chair: David Mukwasa
Rapporteur: Geoff Bardsley

Participants: Basavraju
Cairo
Constantine
Dubey
Feinberg
Ghosh
Hodge
Ipsas
Lindsley
McCambridge
Nanda, D
Noon
Schoendorfer
Seddiq
Tardif
Winters, D

1. Is it better to deliver any wheelchair than no chair at all? If so, in what situations?

It was agreed that:

1. It should be accepted that some form of mass distribution system initially is likely to be the most effective way of providing wheelchairs to the enormous numbers of people with simple requirements which can be met without a detailed assessment.
2. Need to agree recommendations for improvements to designs of basic wheelchairs – need for strong clear guidance on appropriate designs. Manufacturers appear to be receptive to this.
3. Agree would like to encourage manufacturers (and all stakeholders) to require distributors/providers to use appropriate assessment/prescription/fitting depending on complexity of user's disability – where skills are not available help should be sought (see 5 below)
4. Aware that demanding too elaborate system of provision is not practical in many places and could restrict provision to large numbers of people with basic needs.
5. Suggestion use tiered system of provision based on 'triage' process:
 - Basic needs:* paper based system (standard referral information including dimensions) appropriate size basic chair sent; high volume very rapid system but screens out more complex cases
 - Level 1 - more complex:* seen by people with very basic skills quickly (e.g. 40 minutes) and provide with fitted basic chair possibly with accessories (e.g. pressure relief cushion)
 - Level 2 - even more complex:* increasing skill time (e.g. 2 hours) required and likely to need more complex equipment.
 - Level 3:* – unsure of parameters of this level

Syndicate D4 report

Chair: Ray Mines
Rapporteur: Tone Øderod

Participants: Bayer
Castellon
Constantinescu
Curtis
Frost
Hamudenga
Khadiri
Lyimo
McDonald
Nanda, R
Pearlman
Seifert
Sovann
Umarshankar
Urseau
Winters, G

2. What are the strengths and weaknesses of different methods of wheelchair provision?

Discussion was held on the differences between National and Imported production facilities and whether we need the two different categories.

Conclusion was that it is the principle and standards for local market versus standards for export market that are important. Standards depend on the requirements in each country.

One factory could manufacture for different markets, meeting different national standards. Some countries do not have standards.

There are three variables:

- Closeness to the user
- Scale of production (efficiency, labour, costs, etc)
- National or imported; imported devices functional qualities are dependent on the purchaser understanding the user needs.

National products are in general more accessible for the local markets.

Worldmade is new approach that does not fall directly into the table:

Volume	Example	Strengths	Weaknesses (Challenges)
Small (<50/mth)	Small workshops	<ul style="list-style-type: none"> • opportunity for individual customisation • more user friendly • stronger opportunity for stronger relationship and feedback between user and manufacturer • opportunities for better repair, follow-up, services • quicker innovation for design and making solutions to a problem, adaptation of products • often connected to other related services • greater impact on economical growth in the region, labour possibilities for person with, disability • use local materials, spares, service repair, is easier to do locally • lower start up costs • do not need big infrastructure • potential to grow to a medium factory and respond to the national needs 	<ul style="list-style-type: none"> • often dependent on other activities (NGO, humanitarian,) (sustainability) • cost of doing business is often too high for, not enough resources for doing business and marketing • often limited access to modern technology • lack of capital for expansion • lack of attention to safety, because of lack of training • often no access to trade union • every worker is more recognised in a small workshop
Medium (50 - 500/mth) largely based on national manufacturing	Larger workshops / small factories	<ul style="list-style-type: none"> • more structure than small • often local • more appropriate • better option for outsourcing than small • possibility for export • possibility for more efficient local and regional distribution • greater opportunity to be connected to the end user and still have larger volume • able to be dynamic • easier to react to the needs • stimulate local economy • create work for disabled people • contributing to sustainable economy • in between the small and large (unique group) • potential to grow to a large factory and respond to the national needs • opportunities for donor funding • access to spares • opportunities to expand to make appropriate products and to meet national standards 	<ul style="list-style-type: none"> • lack of capital • still donor dependent

<p style="text-align: center;">Large (>500/mth)</p>	<p style="text-align: center;">Large industrial supplier to domestic market</p>	<ul style="list-style-type: none"> • economy, large numbers cheap cost for raw materials • lower production costs • buying power, cheaper parts, buy volume • lower price to the consumer • better opportunities for testing and quality control • opportunity to have wider product range (using same components for different products) • access to a wider market • more economical resources to invest in product development and to expand • better access to research and new, technology, • better possibility to transport throughout the world • more focused on business, profit 	<ul style="list-style-type: none"> • more focused on business, profit • often lack of end user input that give an impact to the development • maintenance and after sales services is difficult • consideration of environmental impact (political/ethical) • risk of labour health and safety regulations not being applied in full • ineffective trade union functioning in some countries
--	---	---	--

Plenary discussion: Syndicates D

Chair: David Constantone

Rapporteur: Alida Lindsley

1. Is it better to deliver any wheelchair than no wheelchair at all? If so, in what situations?

Statistics suggest 85% of wheelchair users are basic users that require minimal services. Subsequent warning for group to be careful to use statistics as we have proven that accurate information from the context we are talking about do not exist. Additionally we should understand that statistics from the UK or other industrial countries are not applicable to this field.

Encouragement expressed that we look for concrete solutions.

'Any' wheelchair could mean a wheelchair made, for example, from paper which is obviously not appropriate. It is suggested that a minimum standard is needed to define what a wheelchair is.

Criticism expressed that the question up for discussion is not that useful. The question starts with a negative. Group is encouraged to get past looking for exceptions and start looking for solutions. Keep the solutions few, with directive and critical points where we can come to consensus and lead to progress.

Comment regarding the tiered system reported on by Syndicate D3: is anyone aware of simple training (on a village or community level) out there that could reasonably do a needs assessment, etc.? Does it exist already?

These responses ensued:

- There is a system in Kathmandu, Nepal. A group that Wheelchair Foundation works with that did training on a community level.
- Motivation has developed a course on wheelchair assessment and prescription.
- Someone is conducting training in the Philippines for children with disabilities. The training covers the identification of needs of children with disabilities.
- From community based health experience: dehydration of children. There was a list of indicators developed and used to tell health staff when a situation was beyond their capabilities. We really want to affect policy, minimal expectations, minimum skills and level of awareness.
- Mobility India trains CBR worker (even management of CBR programme). Information provided about the programme in each conference folder.
- In South Africa there are multiple training programmes. The next step is to attain accreditation of these programs by the government.

Concern with the statement that the group keeps using: "minimum design". This does not represent the variety of designs/chairs that are needed (e.g. supportive seating, highly active sports chair, etc.).

In response to item 2 of Syndicate D3 list: providing recommendations for improvements to designs of basic wheelchairs, etc. Speaking on behalf of the whole room, speaker offers communities experience and suggests a discussion about design and technical issues. Speaker expresses concern about the focus of the discussion and if a usable outcome can be accomplished and if the outcome will be used at all.

Suggestions to look at the two "final answer" statements made by Syndicate D1 and see if they can be linked to the two statements to prosthetics and orthotics. Supplying prostheses and orthoses without some sort of fitting is not done.

Direct response to previous comment, that the speaker likes the analogy of the services in prosthetics and orthotics for sports wheelchairs because the athletes need a very precise fit, **but** realistically, some wheelchairs can be delivered without services so this statement is not fully accurate.

What about user feedback? We have heard from quite a few educated/enlightened users (in the room), but we have not heard from someone who does not have a wheelchair. What would they say to the choice of having no wheelchair or an “inappropriate wheelchair”?

Summary by Chair: Opinion is that a basic level of training in assessment and seating at a series of levels is needed.

We need to build in a way for many people to be seen for wheelchair services: a programme to see people at a community level. We need to find a way to write booklets or other means to get the information out about the basic level of knowledge that is needed. Speaker warns that we need to be careful not to be too pragmatic about our own approaches (the ideal approach). Offering too much information to the lower levels of service providers is not efficient or effective because they cannot always handle the substantial amount of clinical information that we have been talking about over the week.

Many of us have experience in CBR. We have found that you cannot fully depend on them because their level of knowledge is not sufficient and with no linking structure there is not the possibility to access more sophisticated services.

Suggestion to provide categories and qualify the levels of need: certain types of wheelchairs for people with certain needs and disabilities. Can we use this statement as a basis for guidelines/recommendations as in prosthetics and orthotics?

Suggestion to just come up with minimum standards, but also start thinking about what implementation strategies can be used.

Speaker concerned about the concept of ‘minimum’ standards. Standards by definition are the minimum levels that should be used. One can use a higher standard but never use a lower one.

Speaker concerned about the negative energy descending on the group and the focus on the cheapest solution. Speaker reminds us that we can mass produce an appropriate quality chair, e.g. as in South Africa.

Speaker stresses situation that Wheelchair Foundation is in. Until there is a better alternative it will not make changes. Would like to see recommended potential design alternatives rather than just design criteria.

Would the Wheelchair Foundation commit to design solutions?

Cannot say yes certainly, but yes we will entertain them.

Summary by Chair: This week we can break up into smaller groups to actually start coming up with actual tools for:

- *Training of CBR workers*
- *Design ideas and standards*

Motivation has developed training packages for this basic level of services and is willing to offer it.

2. Using the report of Syndicate B3 as a starting point finalize the table of strengths and weaknesses of different methods of wheelchair provision using the report of Syndicate B4 and the plenary discussions to date.

With regard to the mass distribution category, in Uganda they have come up with a way to conduct ceremonies differently with donated chairs. They fit people to the wheelchairs over a few days rather than one and then organize a time for the wheelchair users to return to participate in the ceremony.

Although the group did not look at the strengths and weaknesses at all levels, a summary of the group's discussion was that because of the complexity of issues and systems in different countries, you need all types of provision systems.

It was stated that the field needs to start by quantifying the need (by waitlist) and categorize the need. With this information one will be able to communicate the need to all stakeholders, especially funders and government.

We should have complementary, not conflicting, resources. For example, the Pan African Wheelchair Builders Association (PAWBA) has offered to be a governing organization that is willing to organize the different resources in Africa.

We did have consensus within Syndicate D2: "best practice guidelines" which could be summarised as follows:

If a group is going to go into a country that they should consult the stakeholders within the country to get approval and efforts to coordinate to ensure appropriate service delivery and long term sustainability.

Chairperson: Do we have consensus in the group with this point? Among PAWBA as an organizing body? Among large mass distributors to work through PAWBA?

Wheelchair Foundation says "yes", but disclaimer that donor organizations have ultimate control as to where and who they donate to. Wheelchair Foundation can work to get feedback/communication to go through organizations (such as PAWBA) but not able to promise that communication would be possible or in a timely manner that would allow organization.

PAWBA responds that they would like to be that hub not only for mass distribution but also for manufacturers. It wants to provide a better service for its people. It would like to keep everyone in touch.

Request to see the guidelines to reduce the amount of work of the group. The answers and information that we are generating might be in there.

3. Using the presentation of Ray Mines as a starting point, develop a table of strength and weaknesses of different production methods.

Chairperson: Would this type of table be useful?

Does not matter where things are made as long as they follow minimum standards and that there is a good understanding/relationship between the different parties involved (producer, service provider and user).

Comment on the strength of small workshops being in closer proximity to the users: unless you have many small shops spread out all over you do not have all users close to manufacturers.

Comment that we need to find a way of incorporating Worldmade into the table.

Clarification on report that a distinction was made between national and imported: the distinction is important. Medium scale is based on national manufacturing.

Worldmade does work within national model because it works on local level with distribution system.

Speaker urges that part of our job is to help small producers work up in scale. The table needs to be more complete to be of use. It does show that we all have more to learn from each other.

Clarification: within Syndicate D4 discussion it was felt that Worldmade was unique and did not fit into the table; it possibly could as medium and large scale, much like CIR/WWI. Speaker points out that these examples are common models for manufacture and distribution in the global market (China to other country such as USA). With this model, the consumer (the large scale donor) needs to be much more aware of users' needs.

Summary by Chair:

Recommendations to be drawn from this discussion:

- *environment and human rights issue at production site,*
- *building of local capacity.*

Summary of discussion on Syndicate D:

- Product standards are needed.
- Some sort of basic training needed for level of services (at CBR worker level) is needed so that they can provide minimum services with mass distribution, bearing in mind that we do not want to exclude anyone at this conference from how they work.
- Mass distributors should work to get approval and coordinate with the local stakeholders.

Further request to see WHO guidelines in order to break the deadlock.

Request Syndicate to define clearer standards/requirements for products and provision.

We keep saying minimum standards, a standard is minimum.

Will receive an expanded summary of the guidelines and a table of contents at the end of the day.

Agreed that two tables would be useful in guidelines: provision and production.

Syndicates E

Questions: Syndicates E

1. What requirements should wheelchair distributors demand of the agencies/organisations which provide their wheelchairs?
(Syndicates E3, E4)
2. How far does an organisation's responsibilities extend when carrying out a distribution?
(Syndicates E3, E4)
3. Regardless of design there is a need for proper standards for wheelchairs for developing countries. What areas should they cover?
(Syndicates E1, E2)
4. What is a reasonable life expectancy of a wheelchair?
(Syndicates E1, E2)

Syndicate E1 report

Chair: Mohammed El Khadiri
Rapporteur: Christine Cornick

Participants: Acan
Armstrong
Bardsley
Basavraj
Bayer
Borg
Burgos
Cairo
Castellon
Charowa
Chen Guang
Constantinescu
Curtis
Fang Lihong
Gall
He Jinming

3. Regardless of design there is a need for proper standards for wheelchairs for developing countries. What areas should they cover?

- **Products**
- **Service**

Reviewed the International Standards (ISO 7176) that exist

Have been written largely for application in developed world but some may be applicable.

- **Static stability:** how to measure and gives a standard weight to use for the test. But doesn't tell you what the static stability should be because an active user for example may want an 'unstable' wheelchair. Possibility to define a recommended stability for developing country?
- **Effectiveness of brakes:** mostly oriented for power wheelchairs. Tip up to maximum angle and see if the brake holds
- **Strength/durability:** tests how strong and durable the wheelchair is. Could be developed for developing country situation with simple modifications to reflect environmental stress put on wheelchairs. In a developing country the testing would need to be much more vigorous testing to reflect normal use. (allowing for maintenance such as bearing replacement, spoke replacement etc)
- **Disclosure (information):** there is a requirement that there should be a manual to go with the wheelchair explaining how to use it. It should also be labelled regarding any special hazards. Basic info for person prescribing the wheelchair

Also: Guidelines document aimed at people who are choosing wheelchairs to enable them to make a good choice (TR13570).

China's own national standards demand a different lifespan for different parts of the chair:

- Push rims/brakes: 4 years
- Frame: 7 years
- Wheels/front castor: no fixed lifespan

Wheelchair Foundation requirements: higher than China - but if wheelchair lasting a short time (e.g. in Zimbabwe approximately 3 months) then it is a clear indication that the ISO/China standards are inadequate for developing countries.

For the standard, we need to find a method to measure a typical/average use in a developing country to determine the standards needed for a chair to last 5 years.

1) Products

- Should last 5 years in a developing country
- Cushion with every chair
- Should be appropriate (i.e. safe from secondary complications, e.g. pressure sores, provides good positioning, etc)

Consider spares provision of items that will wear out during the lifespan of the wheelchair including cushions, particularly in settings where it is not possible to return to the service from outlying areas

2) Services

- Tools for assessments
- Services should specifically cater for the needs of children to be regularly reviewed
- Individual or a team of people who can do assessment, e.g. child may need to be assessed in many different areas
- Possible team members might be PT/ Rehab/CP knowledge/CBR workers/
- Minimum training for the user/care giver in how to use the wheelchair
- Individuals or team need to be trained in wheelchair provision: the people to be trained will depend on the country context.
- Importance of maintenance information to be provided due to the need for the user to maintain the chair for it to last 5 years

Can we ask the producers when they bring the wheelchairs to bring this team?

Can the wheelchair provider include some minimum information to be given to the user with each wheelchair?

General

Recommendation from the group: ISPO to consider how ISO standards and guidelines can be reviewed for appropriateness for developing country context. ISPO to canvas opinion from developing countries for input into those standards and guidelines

Exported chairs have to meet the standard of the place where they are going to be distributed. Many countries don't yet have standards but when they do they can demand wheelchairs meet them.

In Uganda, they produce wheelchairs that follow ISO standards but they are coming up with National Standards. Many wheelchairs are coming into the country, and they are experiencing many problems. So they want to develop national standards and they have been waiting for this meeting for guidance.

Who is setting the national standard, e.g. in India the national guidelines are set without the involvement of the wheelchair user?

Perhaps ISPO could package and provide standards?

4. What is a reasonable life expectancy of a wheelchair?

5 years

Syndicate E2 report

Chair: John Lyimo
Rapporteur: Sarah Sheldon

Participants: Constantine
Deshpande
Dubey
Ezekiel
Feinberg
Frost
Gallay
Ghosh
Hamudenga
Heim
Hodge
Hotchkiss
Ipsas
Jensen
Khasnabis
Krizack

3. Regardless of design there is a need for proper standards for wheelchairs for developing countries. What areas should they cover?

- i. Standards
- ii. Performance characteristics
- iii. Guidelines
- iv. Consumer information

Question: Should product standards be linked to service standards?

Standards

- Safety – user is not endangered by falling out of wheelchair or pressure sores etc – no sharp edges
- Adjustability – so can be adjustable during fitting to needs of user – number of wheel positions
- Postural support based on biomechanical principals
- Quality of manufacture - finish
- Quality of fit
- Durability
- Availability of components for repair
- Necessary components – footrest, brakes etc.
- Compulsory cushion
- Strength – needs to reflect extra needs for impact on castors and footrests in developing countries

Performance characteristics

- Weight
- Ease of propulsion
- Regionally appropriate design – e.g. in some areas wheelchairs need to be more corrosion resistant.

Guidelines

- Aesthetics are important

Consumer information

- Great need for proper information to accompany all wheelchairs. Not all wheelchairs are appropriate for proper groups and need to be used properly to be safe. Clear documentation is needed.
- ISO tests have useful information
- Information re what angle wheelchair tips over at
- Maintenance
- Weight

Testing

- Tests should be based on/come out of ISO standards – guiding norms to develop country standards. Standards should be developed locally to be country or area specific.
- India has its own standards existing. Costs too much to test to ISO standards.
- Manufacturers should have or have access to sufficient testing equipment to ensure that they can meet standards.
- Testing costs are reasonable for large manufacturers. Low cost equipment (double drum, continuous drop, static loader) has been developed and alternative tests have been developed.
- Testing on initial design, or random testing? Importance of quality control stressed
- Enforcement mechanism is people who purchase wheelchairs.
- In India an independent agency exists that is able to report those who do not meet standards that are set out.

4. What is a reasonable life expectancy of a wheelchair?

Points to consider:

- Child size wheelchair – may have different life expectancy
- Even when low cost components fail many people can't afford to repair them.
- Maintainable for life – top end – basic structure not components.
- Possible to design a wheelchair well enough so that a wheelchair flexed at peak loads do not pass fatigue limits or yields. Can then expect a wheelchair to last for life.
- Frame should last much longer than the rest of the components if no accident involved
- When the repairs become more costly than a new wheelchair, should get a new wheelchair.
- Should outlive its cost benefit
- Reality is that wheelchair users do not do maintenance.
- Life expectancy is based on a wheelchair user doing no maintenance
- Need to know a general life expectancy as a funder etc in order to plan well in services when wheelchairs will need to be replaced.
- In India people are eligible for a new wheelchair every 2 years and a higher life expectancy figure could affect this entitlement.

Individual opinions on acceptable life expectancy of a wheelchair

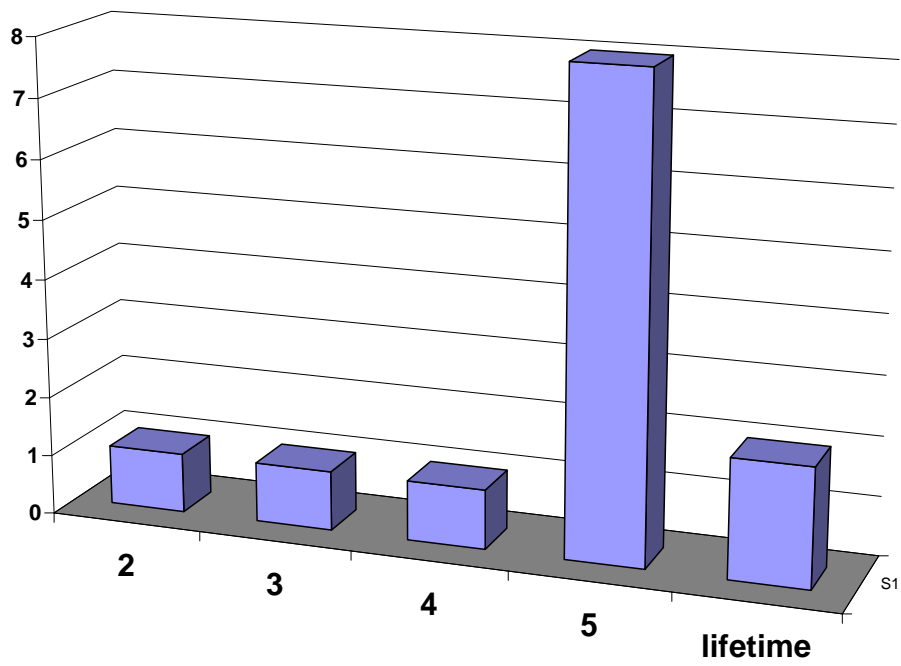
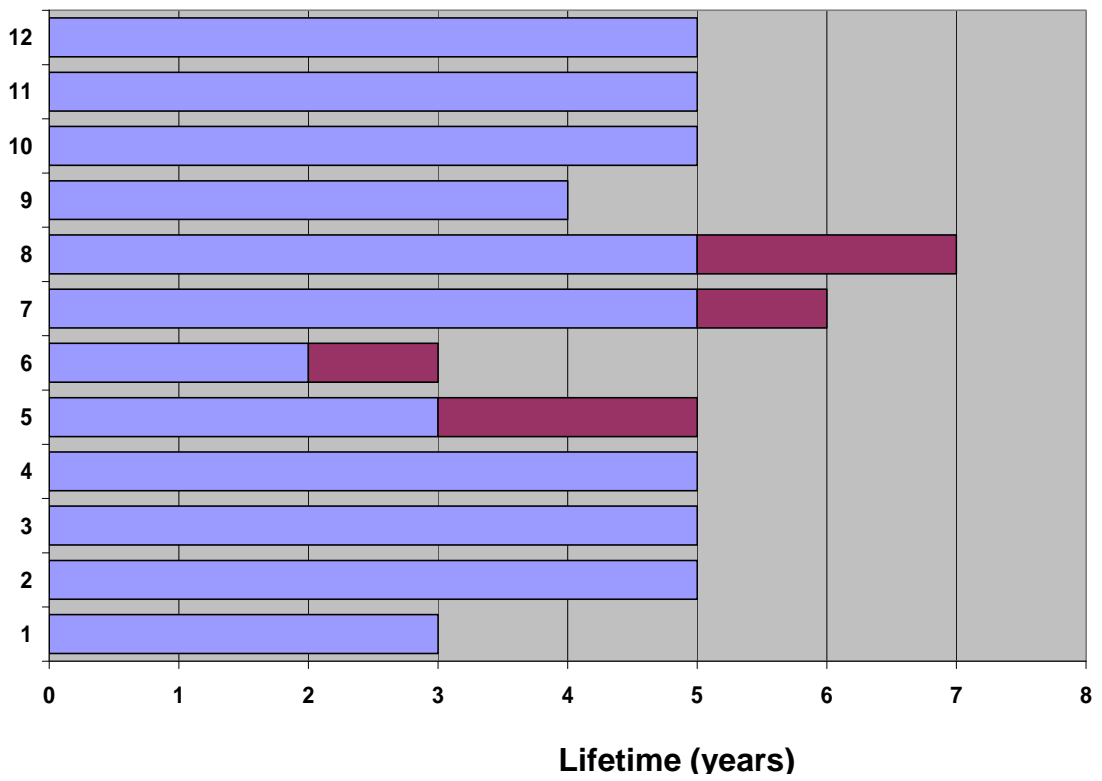

Average opinions on acceptable life expectancy of a wheelchair

Syndicate E3 report

Chair: Jon Pearlman
Rapporteur: Anna Lindstrom

Participants: Lindsley
Madziranzina
Mazard
McCambridge
McDonald
Mines, K
Mukwasa
Munish
Nanda, D
Ndjambula
Nganwa
Øderod
Radhakrishnan
Seddiq
Winters, D

1. What requirements should wheelchair distributors demand of the agencies/organisations which provide their wheelchairs?

Needs analysis of the country/region/setting in consultation with stakeholder groups (including wheelchair users, Government, existing service providers, existing producers):

- Existing services and production in the country
- Local environment, culture
- Needs of wheelchair user population, e.g. prevalence of specific disabilities, locations (e.g. predominantly rural/urban)

(Credibility of the organisation is important – ability to carry out a needs analysis and work with other stakeholders is a way to assess credibility and capacity)

Ensure service provision (possibly working with other organisations/resources/out-source services if they cannot do it themselves) which includes:

- Wheelchair user identification – development of list of wheelchair users, working with referral networks
- Wheelchair user screening (screening wheelchair users to ensure that wheelchairs are provided to the most appropriate user group for the product being supplied)
- Assessment, prescription, fitting, follow-up
- Training and education of wheelchair users
- Record keeping
- Maintenance and repairs (discussion of follow-up time period)

Training/skills to deliver service provision

- Trained already
- Go get training
- Invest in local staff training

Other considerations:

- Users to be involved in the provision
- Work with Government and other stakeholders
- Reduce emphasis on donor ceremonies and rapid distribution
- Consider long term sustainable supply of wheelchairs and service provision – what are the sustainability opportunities in-country
- Consider impact on local wheelchair production – this could mean not providing free of charge
- Capacity to handle local logistics (e.g. customs, storage)

2. How far does an organisation's responsibilities extend when carrying out a distribution?

Responsibilities of the people handing out the chair are:

- Ensure the product provided meets standards. Requires national standards and quality control mechanism – to check appropriateness.
- Education responsibility – give the user information to know how to use the wheelchair (user manual to give information).
- Offer spare parts services and maintenance
- Learn about the products that you distribute
- Responsibility to the user – to provide information, training, receive feedback
- Responsibility to the distributor (supplier) to fulfil your contract / agreement with the distributor
- Provide equitable distribution, not first come first.
- Recognise that all stakeholders are accountable – regardless of whether input is voluntary/donated.

Syndicate E4 report

Chair: Venus Ilagan
Rapporteur: Jamie Noon

Participants: Mines, R
Nanda, R
Reisinger
Scheffler
Schoendorfer
Seifert
Semakula
Shangali
Sovann
Steenbeek
Suvapan
Tardif
Umarshankar
Urseau
Vennila
Winters, G

1. What requirements should wheelchair distributors demand of the agencies/ organisations which provide their wheelchairs?

Definitions:

Distributors produce wheelchairs and make them available to “agencies” for provision to users. Examples include: WCF, FWM, ALIMCO, CIR and Motivation’s Worldmade programme.

Agencies/organisations are: service locations, donor/funders, local partners

Suggested requirements:

- a. Distributors require that individuals providing services should be properly trained to: identify, assessment, prescription, fit, provide user training, maintain, and follow-up.

Note: “training” levels range from very basic to in depth, depending on the needs of the recipient/user group.

- b. Distributors require that the agencies / organization are capable of appropriate application of the wheelchairs being distributed. This is ensured by demonstrating that the service staff have knowledge of the wheelchairs being provided, their limitations and intended use, including possible adaptation to the wheelchairs to meet individual user needs.
- c. Agencies should be instructed to accept only the number and type of wheelchairs that can reasonably be distributed safely and appropriately.
- d. Before shipping, the distributor should confirm that the organization is willing to accept the donation.

The diagram below illustrates a transition from current workflow (dotted arrows) to desired workflow (solid arrows):

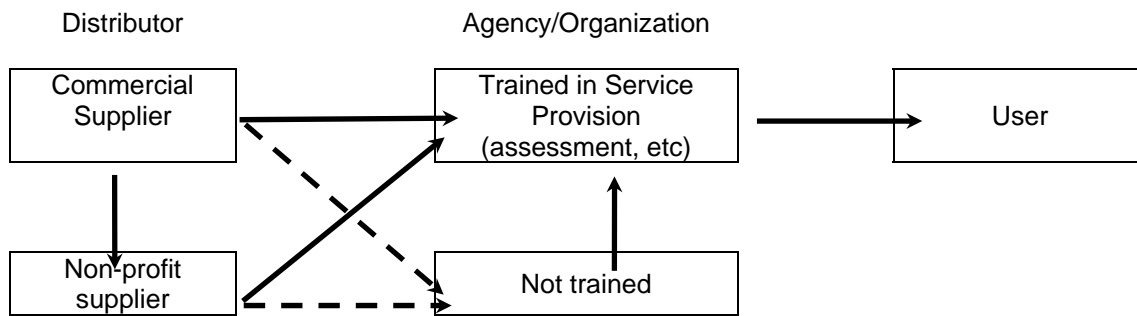

Q1 Discussion points:

- Agency and distributor are ethically and legally responsible for inappropriate service
- Capacity building of agencies
- Wheelchairs should be distributed to/through established agencies/organizations.
- List the users who wheelchair is intended for and pre-screening required
- Have capacity to identify appropriate clients. (distributor ships and agency often does not have capacity)
- Must include range of wheelchair models in services
- Distributor, “If you have capacity we will work with you now. If not we’ll wait to provide wheelchairs”
- WCF contract excerpt is good.
- Require system of feedback to distributor regarding product performance (agency responsibility)
- Example: In PNG there are three types of system; 1. website purchase from Taiwan (no requirements), 2. Motivation Worldmade (with service training only), 3. WCF (provide names and photos)
- Minimum to provide assessment
- Ensure availability, affordability of spare parts (distributor requires of agency and visa-versa)
- Example: In Cambodia there is no source of spare parts available for imported wheelchairs. Local producer (distributor) trains assessment skills to agency/ organization
- Example: In Tanzania, spare parts are not locally available. Suggest agreement with distributors to make available parts not found in market
- Must demand local responsibility of ministries and local healthcare systems to provide follow up support (spare parts?) for a period after the chair is provided (X years)
- Must demand agency has trained personnel, but to what levels?
- Distributor could do training in assess, fit, maintenance before sale
- Distributor requires minimum knowledge of local conditions at distribution location (i.e., active capacity development efforts and existing local production). Oversight authority (ISPO?) may disseminate information via website?
- Individuals involved in direct end user contact should be required to have a degree of training depending on the needs of the recipient group
- Who will evaluate product?
- Example Flemish government help to set up service before donating

2. How far does an organisation’s (government, agency, service provider...) responsibilities extend when carrying out a distribution?

Responsibilities:

- a. To identify, assess, prescribe, adjust, fit, provide user training, follow-up, maintain, feedback. Feedback to include details for different user need categories which are not addressed by the wheelchairs provided.

- b. To ensure that services are in cooperation with (not in isolation of) functioning healthcare and social service system where they exists.

Q2 Discussion points:

- Example Thailand: Government level distribution (centre based)
- Organizations must make sure these steps (a) are part of the provision of wheelchairs
- Ensure long-term sustainability of services (wheelchairs should be distributed through established organisations)
- Who is the risk bearer?
- Who will be sued if there is a legal case brought against parties involved in provision of a wheelchair?
- The distributor has an obligation to check quality. A liability chain extends throughout the distribution chain.
- All parties have responsibility not to impose on those after them on the chain. Distributors (manufacturers) should not impose their version (of appropriate products) on users or organisations.

Plenary discussion: Syndicates E

Chair: Harold Shangali
Rapporteur: Marc Krizack

- 1. What requirements should wheelchair distributors demand of the agencies/ organisations which provide their wheelchairs?**
- &**
- 2. How far does an organisation's responsibilities extend when carrying out a distribution?**

K Mines: Reduce emphasis on fast decisions and service provision. Need or request usually comes from one organization in country. Providers should ask other stakeholders before going with the one requester. Multi-stakeholder consultation and needs assessment before bringing in wheelchairs. It is a good test of local organisations' capacity to network and carry out the needs analysis.

Hodge: The Wheelchair Foundation asks local organisations to do a needs assessment and to hire someone to do it. It is difficult to get responses in a timely fashion. Responsibility is basically on the local organizations to be proactive. In Mexico, they did to a needs assessment and chairs went to people identified by qualified identifiers.

Gall: Need to ensure that you have the right information.

Seifert: Most imported wheelchairs are distributed by service clubs and religious institutions that have no expertise. Rotary has approached APDK with short notice, but they now reject this approach.

R Mines: Networking and keeping other stakeholders involved is important. Recommends that ISPO facilitates a database of stakeholders by country.

Constantine: Need a responsible distribution of wheelchairs.

Hodge: Efforts being made to educate distribution base.

Cornick: It must be realized that there is a cost to appropriate distribution. If you are going to provide products you should provide service.

Curtis: Do large scale providers ever post on their websites the dates of deliveries?

R Mines: A good idea. Invitations should be made to large-volume distributors to participate in stakeholder conferences whenever they are happening.

Bardsley: Donors drive mass distributors. They are not aware of the requirements to donate products in a useful way. Need information under a WHO banner to enlighten manufacturers of what is necessary, without knowledge of subtleties and complexities.

Nganwa: Need a 'requirements for distributors' example; one church to another church that bypasses the users and experts should be avoided.

Siefert: There is place for quality imported wheelchairs. There is an 80% demand for tricycles. We prefer to sell our own because we know they will last and can be maintained.

Basavarju: Rotary and Lions act on very short notice. They need guidelines of what to do. Time is required for 1 or 2-day stakeholders' workshops. How can we make good use of the resources and do it better?

Castellon: Wheelchairs often go into the black market after a donation.

Constantine: Basavarju's idea is good; having meetings between donors and agencies would be very useful, whether they be large or small meetings.

Nganwa: What about the use of second-hand wheelchairs

Hotchkiss: It is harder to fix second-hand wheelchairs than build new ones from scratch with appropriate materials. Hybrid chairs were made for a while but this was found to be a bad use of resources

Cornick: Should follow-up distributions and build local capacity; not just distribute and go.

K Mines: Regarding financial sustainability, a free distribution approach means less motivation in a country for the government to plan or fund for wheelchair provision. Long-term sustainability needs to be a requirement that needs to be considered.

R Mines: Are we focusing too much on the wheelchair? Can we shift to other issues such as infrastructure?

Curtis: Organisations are created by founders with vision to take care of a particular problem. Why should an organization take on the full problem?

K Mines: There should be a consideration of not providing chairs for free and that this should be considered by the providers.

Horvath: A lot of money is coming from individual donors to fund the supply of wheelchairs the problem is that it is hard to raise money to fund staff to manage the service in-country.

Constantine: A computer without software is useless.

Gall: How should the distribution costs be funded, free distribution affects local suppliers?

Krizack: A reasonable fee levied on imported chairs to pay for the necessary service might provide a solution.

3. Regardless of design there is a need for proper standards for wheelchairs for developing countries. What areas should they cover?

&

4. What is a reasonable life expectancy of a wheelchair?

Pearlman: In India, government scheme only applies to poor wheelchair users

Scheffler: China standard seems like the South African.

Cornick: The Chinese standard was supposed to be higher, e.g. the frame needed to last 7 years.

Jinming/Lizhong: Most specific items are different. Duration of Chinese National standard is 500,000 cycles. ISO test attach fork and front caster 200,000 cycles. These different requirements lead to different choice of material, different materials for different countries.

Bardsley: ISO is used to test an expected 5 years of durability, ISO test has double drum, with strips but Chinese have no bumps on the drums. Maybe this is cause of early breakdown of chairs from China in Zimbabwe. ISO have a kerb drop test, is there one in China too?

Jinming/Lizhong: China is looking to upgrade its standards.

Pearlman: Fundamental difference between those standards

McCambridge: In the US in many products there is a national minimum standard and allow local states to go higher if they wish.

Scheffler: Cheaper chairs that do not meet South African standards drive out the local manufacturers. A lower standard wheelchair will not be replaced by the agency until 5 years.

McDonald: Wheelchairs that break within one year do not meet the need.

Mukwasa: In Zambia, Disascare has been asked by national government to come up with a national standard.

Pearlman: Need to educate local governments, but more important for us is to take responsibility for the wheelchairs we are providing. However, part of the programmes should be related to educating government and developing policy.

Bardsley: Need means of implementing and enforcing. Within Europe there is heavy legislation concerning medical devices. These are serious as they include devices such as implants, so make wheelchairs be dealt with as a medical device. Lobby government to recognize importance of wheelchairs.

Siefert: When are the WHO guidelines expected to be adopted?

Gall: Also donors must ensure that the wheelchairs that they fund meet standards

Constantine: Agree with Bardsley. If being a medical appliance helps that is OK. However, as a user I do not see my wheelchair as a piece of medical equipment.

Horvath: Recommend that ISO develops a more rugged standard that is not based on being pushed through Berlin. Also, last year USAID made a policy regarding the construction and reconstructing of schools and other infrastructures in USAID programmes; that if local standards were better than those in the US, they had to be implemented.

Scheffler: Wheelchairs that meet ISO standards seem not to be durable in the more rugged terrain of Africa.

Sheldon: The WHO guidelines are due to be published next year and launched at ISPO 2007 and maybe next year to be voted on by member states.

Pearlman: Simple adjustments can be made to ISO standards to make them appropriate. An ISO testing laboratory can be equipped for approximately US\$5000.

Hotchkiss: Agree with Pearlman. There are problems with the ISO but they are a great first step. Numerous wheelchairs are available that far exceed ISO standards. They last many years in the field. The higher standards are the cheaper chairs will be per year of use. Difference between non-ISO and ISO wheelchair cost is very little. If they are very strong, it will protect the wheelchair builders and the riders far better than the presumption of a disposable wheelchair. It will not protect exporters of sub-standard chairs, but it is easy for them to improve.

Summary by Chair:

There is a need to review ISO standards, need to look into product and service standards and performance characteristics. There is a consensus on going ahead and looking into the standards that are appropriate. There is also agreement on a 5 year minimum durability for a wheelchair.

Syndicates F

Questions: Syndicates F

1. There is a need for standards in product design. What areas should be covered? Are there any requirements that can be specified?

(Syndicate F1)

2. There is a need for standards in the provision of the wheelchair to the user, i.e. service provision. What areas should be covered? Are there any requirements that can be specified? (Include a bulleted list of prescription criteria in your answer).

(Syndicate F2)

3. There is a need for education and training for all people involved in wheelchair provision. Who should receive the education and training, what areas should be included and to what level?

(Syndicate F3)

4. There is a need for guidance in distributing wheelchairs to the service provider. What areas should be covered? Are there any requirements that can be specified?

(Syndicate F4)

Syndicate F1 report

Chair: David Constantine
Rapporteur: Bill Armstrong

Participants: Chen Guang
Constantinescu
Fang Lizhong
He Jinming
Hodge
Hotchkiss
Lindsley
Mazard
McCambridge
Mines, R
Noon
Pearlman
Schoendorfer
Seddiq
Umarshankar
Winters, D

1. There is a need for standards in product design. What areas should be covered? Are there any requirements that can be specified?

With all syndicate members present, the following list was reviewed and a full consensus was achieved on each item.

Due to time constraints of this syndicate there was unanimous consent to appoint a representative sub-committee with the mandate to explore each of the following specifications in greater detail and to develop recommended minimum standards within each category. It was further agreed that there would be value in testing current wheelchair designs from each of the represented organizations. There was discussion and agreement that these recommended standards would be of an advisory nature rather than requirements.

Static stability: Front, lateral, diagonal and backward tipping for least and most stable axle positions

Effectiveness of brakes – ISO standard with set angle for tipping of chair and angle at which brakes hold – test for sudden release of the brakes

Strength durability: stress testing of front casters - structural integrity - peak force or yield failures and double drum (fatigue) test (peak force test after double drum)

Pressure relief cushion: Compulsory – Ratings for cushions - Determine levels Standard test using indenter – concern about cushion changing Centre of Gravity – life of cushion - develop test equipment

Safety: Pinch points and sharps, self-locking nuts

Dynamic stability: Declining ramp with obstruction to cause abrupt stop of wheelchair (testing to assure wheelchair user remains in wheelchair after abrupt stop)

Adjustability: footrest adjustment range, brake adjustment
Informational - armrest height, backrest height range
Range - seat width/depth, fore/aft rear wheel position

Postural support: all body contact surfaces supporting adequately (e.g. footrests) – wait for ISO standards on Postural Support Devices. Sub-committee will revisit within 6 months and make recommendations.

Quality of manufacture: durability testing – sample size and frequency for product testing (quality control) – sharp edges and points - corrosion resistance - fit and finish

Availability of components: manufacturer ensuring availability or provision of needed parts – reporting any possible hard-to-find parts/components. Work towards common components/parts across different manufacturers. Consumables separate from replacement parts.

Send to committee:

Tracking
Transportability
Flammability

Disclosure/information:

Seating dimensions
Overall dimensions

Sub-committee members (partial list):

Bill Armstrong
Stephan Constantinescu
Joel Hodge
Ralf Hotchkiss
Alida Lindsley
Jamie Noon
John Pearlman
Don Schoendorfer
David Winter

Syndicate F2 report

Chair: Chapal Khasnabis
Rapporteur: Johan Borg

Participants: Bardsley
Basavraju
Cairo
Castellon
Curtis
Gallay
Hamudenga
Jensen
Krizack
Madziranzina
Mines, K
Nanda, R
Øderod
Scheffler
Steenbeek
Tardif
Urseau

2. **There is a need for standards in the provision of the wheelchair to the user, i.e. service provision. What areas should be covered? Are there any requirements that can be specified? (Include a bulleted list of prescription criteria in your answer).**

Preamble

User participation is an integral part of wheelchair service provision.
Government has the primary responsibility for sustainable wheelchair service provision.
Wheelchair service provision should be an integral part of national disability/health/rehabilitation policies.

Aim

To ensure that people in need of a wheelchair receive it with necessary advice and support, which adequately meets the needs in terms of mobility, comfort and ability to carry out activities of daily living and exercise basic human rights.

Areas	Requirements
Awareness	<ul style="list-style-type: none">▪ Basic information about needs for and benefits of using wheelchair (e.g. leaflet with information about who needs a wheelchair which is distributed to different organisations based on available services (to avoid expectations that cannot be met))▪ Involvement of DPOs if possible▪ Involvement of CBR/community health/educational personnel
Screening/ Identification/ Referral/ Networking	<ul style="list-style-type: none">▪ Simple screening tool to identify those who can benefit from the use of a wheelchair and to identify the complexity to understand if the needs can be met with available services, also to identify what other needs the person has▪ To identify simple to complicated interventions▪ Identify referral pathways▪ Networking with local government and community development organisation▪ Use existing resources/network (human resources)▪ System for registration (for follow-up) to identify what services need to be developed

Assessment	<ul style="list-style-type: none"> ▪ Individual assessment (e.g. with an appropriate/simple assessment tool which can be adapted or modified depending on situation and context) ▪ By trained people ▪ User involved ▪ Establishing a wait list ▪ Assess medical/health/functional condition ▪ Individual rehabilitation plan
Selection (Specification/ Prescription)	<ul style="list-style-type: none"> ▪ Technical and functional description of a suitable wheelchair (prescription) ▪ Information about available wheelchair ▪ Need for modifications/adjustments ▪ Need for extra equipment ▪ Basic guide for self-care ▪ List of individual needs
Procurement	<ul style="list-style-type: none"> ▪ Choose supplier ▪ Funding ▪ Time to wait for the wheelchair
Product preparation	<ul style="list-style-type: none"> ▪ Assembly, if necessary ▪ Cushion ▪ Adaptation including seating system
Fitting	<ul style="list-style-type: none"> ▪ Necessary alterations ▪ User trial in local environment ▪ Finalisation of wheelchair
User training	<ul style="list-style-type: none"> ▪ Basic training should include – safety, transfer, basic mobility/handling, basic maintenance, self care/pressure relief, who to contact if something goes wrong, impact/risk of self-modification ▪ Final check-out
Repair and maintenance	<ul style="list-style-type: none"> ▪ Local repair ▪ Provision of basic spare parts
Follow-up	<ul style="list-style-type: none"> ▪ Re-assessment, specially of users with progressing/changing conditions, e.g. children ▪ Use of existing networks, e.g. CBR
(Accessibility)	<ul style="list-style-type: none"> ▪ Facilitate home modifications/barrier-free environment
General Management	<ul style="list-style-type: none"> ▪ Coordination of donations ▪ Development of services ▪ Sustainability ▪ Financing plan (including subsidy) ▪ Network of service providers/users ▪ User involvement/feed-back ▪ Evaluation of service provision

Start to make a simple assessment tool with core questions – possibility to add optional questions to meet additional requirements.

Syndicate F3 report

Chair: Sepp Heim
Rapporteur: Shona McDonald

Participants: Burgos
Cornick
Ezekiel
Ghosh
Lindstrom
Lyimo
Reisinger
Shangali
Sheldon
Vennila
Suvapan

3. There is need for education and training for all people involved in wheelchair provision. Who should receive the education and training?

Training needs to have measurable outputs. It should be based on module system with different entry and exit levels. Need to define the categories of training.

A. Information: It was discussed that the donor and government would require more awareness and information rather than training.

B. Training: It was discussed which group would need training and the involvement that is needed. We also discussed that in many places professional staff do not have existing knowledge on seating and wheelchair services.

What about peer training? It can be included within the module system and also as an independent training programme (broader than wheelchair provision, e.g. life skills)

Everyone involved in the wheelchair service provision and distribution team needs training:

- Physiotherapist
- Occupational Therapist
- Doctor
- Nurse
- User
- Carer/Assistant
- Prosthetist and Orthotist
- Technician
- CBR personnel
- DPO/Rights group

It was agreed that there is a need for formal wheelchair specialist training – to upgrade the professional skills/status however we need to be clear about their levels/category.

These people may not be producing wheelchairs but only doing the repairs and follow-up. Many professionals are involved in a very small way as part of wheelchair service. To begin with, we need to start formal wheelchair training, and standardize as has been done in Prosthetics and Orthotics courses.

There were some resistance in the beginning when the one year training programme in wheelchair technology was developed. However, now there is a suggestion to increase the course to two years in future; possibly in a modular training format which also includes supportive seating.

- Need tier system training and organic - develop based on the activities needed for wheelchair provision
- Need progressive training for wheelchair technology
- Consistent training could be modular
- Train groups in cross-skills
- What will be the content if we are looking at the development
- There will still be a need for short courses, modular and distance learning
- Wheelchair components should be included in curriculum of rehabilitation professional courses as a first step
- Ultimately responsibility lies with government for the people in their countries.
- Possibility to include wheelchair studies into prosthetics and orthotics curriculum

Conclusion

- Specialists should be trained in wheelchair production and provision (Wheelchair Technologist).
- Special modules are needed for the different groups who are members of the team
- Very comprehensive information must be provided to different stakeholders (including government)
- Peer training needs to be structured/formalised

What areas should be included and to what level?

- Basic paramedical knowledge
- Basic pathology
- Basic extended mechanical knowledge
- Assessment
- Large varieties of products
- Repair and maintenance
- Fitting
- Adjustment
- Prescription
- Modification
- Social context/health structures

There was discussion on the need for different levels in a modular system e.g.

Level 1- Assessment and prescription

Level 2 – Seating and modification

Suggestion – to create group to prepare Wheelchair Technologist profile and content of module training

Syndicate F4 report

Chair: Cristian Ispas
Rapporteur: Alice Nganwa

Participants: Acan
Bayer
Charowa
Deshpande
Dubey
Gall
Ilagan
Kalemi
Khadiri
Mukwasa
Munish
Nanda, D
Ndjambula
Seifert
Semakula
Sovann
Winters, G

4. There is a need for guidance in distributing wheelchairs to the service provider. What areas should be covered? Are there any requirements that can be specified?

a. Guideline for supplier (donor or distributor)

Criteria used by the distributor for selecting a service provider/partner:

- Proven track record of activities and evidence of registration (avoid briefcase organizations),
- Financial stability (annual reports of activities)
- Ability to deal with customs and clearance of goods
- Transport of wheelchairs to distribution site
- Provide security and good storage
- Able to assemble, replace parts -maintenance (specifically required by a distributor)

b. In-country partner (service provider, charity organization, government etc.)

Team composition:

- Guided on team to carry out actual assessment of users; must specify who is on the team; at least one of the rehabilitation team (trained medical profession), preferably physiotherapist, prothetist/orthotist, doctor, peer educators, CBR worker, wheelchair technologist/technicians or trained in wheelchair issues.
- Some team members should be trained in assembling wheelchairs

Planning

- Pre-assessment: list of users (waiting list)
- Needs assessment of users (could be the information available nationally)
- Aware of existing structure, i.e. know local/country guidelines/regulations
- Has discussed with all stakeholders before distribution—this may slow down the process due to bureaucracy and corruption
- Aware of standards and that product meets the standards (distributor's responsibility mainly)
- Referral network must reach rural areas: referral from DPOs, outreach/camp; must reach marginalized
- Must have a network for distribution
- Adequate capacity and network to reach target group

- Equity of distribution, e.g. slum and rural where information does not reach

Clinical assessment and fitting

- Make sure every wheelchair has a pressure relief cushion
- There is a range of wheelchair size available
- Services to be provided with the distribution
- All parts of the wheelchair should function properly before distribution
- Guideline or protocol or manual (i.e. manual for operation, maintenance and repair, materials used)
- Respect choice of user
- If possible provide a range of types of chairs, e.g. 3 or 4 wheel
- Care to provide suitable support especially for children with cerebral palsy
- Type of chair based on user's needs
- Adjustment of the wheelchair and adaptation of the wheelchair
- *Guidelines followed very closely for the complex disabilities, e.g. spinal injuries but not for disabilities with simpler requirements, e.g. to move to school only - perhaps have different guidelines for different disabilities.*

User training

- Wheelchair skills
- Set of minimum user instructions, safety and maintenance.

Maintenance and repair

- List of providers of the parts to help with repair
- Ensure availability of spare parts

Follow-up and feed-back

- Mechanism for periodic follow-up and feed-back
- Data collection, accountability
- System to protect against users abusing the system – receiving wheelchairs repeatedly

Sustainability

- Government to provide accreditation to service providers and where possible pay for distribution
- Service provider, should where relevant, involve Government especially if it is to become part of the system.

There is need for coordination - parallel systems with government waste resources. Government should preferably be collaborators with service providers and not competitors.

Plenary discussion: Syndicates F

Chair: Rob Horvath
Rapporteurs: Sarah Sheldon
Norman Jacobs

The following comments were made during the discussion:

1. There is a need for standards in product design. What areas should be covered? Are there any requirements that can be specified?

- Strength and durability: take out 'peak force test after double drum',
- Weight? Not addressed. Could be an item of consumer information. Feel it is too design restrictive to indicate maximum weight.
- Postural support devices: ISO standards almost finished so can be used.
- Not sure need another standard for children. Range of sizes of dummy used to load wheelchair and use smaller size for children.
- Agree many of requirements equally apply to children's wheelchair.
- Manufacturer should also indicate maximum weight capacity of device.
- How do we indicate postural support requirements to be of use? Solution, Elsj Scheffler or Shona McDonald to join sub-committee if appropriate.
- How to deal with castor floatation: soft ground recording test. Is there a possibility of recording whether wheelchair is appropriate for soft or muddy ground? Sub-committee could work on castor floatation.
- Safety: need for reflectors on wheelchairs? Agree very important issue. Would like to see a standard requiring visibility on all wheelchairs.
- Value of testing current wheelchair designs. In South Africa have already drafted tests. German dimensional characteristics. Performance: indoor and outdoor. Want to invite anyone that is interested in research. Ultimate purpose is to provide fitting guidelines for different wheelchairs.
- Durability: is it possible to recommend ranges of different types of materials? People compromise for cheapness.
- Oxidation is issue that is needed to be worked on. Regarding issues of environmental conditioning, have talked in guidelines a lot about long-term user trials which one would not get from testing.
- Could develop strong statement: everybody should comply with ISO standards which would move things forward. Would give some idea of minimum strength and deal with wheelchairs with substandard materials.

2. There is a need for standards in the provision of the wheelchair to the user, i.e. service provision. What areas should be covered? Are there any requirements that can be specified? (Include a bulleted list of prescription criteria in your answer).

- Clarification: 'Screening etc.' should read 'who can benefit'
- Awareness: involvement of DPOs – take out if possible.
- Assessment – leave out appropriate/simple
- Please highlight a few items related to prescription.

- Response: cannot take it for granted that DPOs will always be there especially in rural areas.
- If there is no disability organisation in the rural area can bring a representative from the urban to the rural area. Many organisations are trying to extend reach and this is a good chance for interface.
- Response: reality is difficult and takes some time.
- Whole table could be divided into essential and desirable. In some places a service can stand without, for example, procurement, awareness and management.
- This is a great start, but only had 1.5 hours to do it. The time available limited what could be put in. Needs tidying up. In order to become a finished article. Need a group to work on it. Prescription guidelines, timing, performance of service missing.
- Have presented skeleton. If agree it can be fleshed out.
- A few things are not very practical. Might be solved by identifying things as essential or desirable.
- Between awareness and screening should add another role for mobilisation and identification and waiting list.
- Service provider to lobby government to provide accessibility.

3. There is need for education and training for all people involved in wheelchair provision. Who should receive the education and training?

- Recognition of courses important. Training courses in wheelchair technology should be recognised.
- ISPO has registered interest in wheelchair courses; it has already recognised the training course in wheelchair technology at TATCOT. It would be wise to develop a curriculum as a guideline for others to follow.
- WHO: how feasible and practical is it for the group in the suggested list to be trained in wheelchair provision knowing fully well that these professions are under-represented in developing countries? How many countries in the industrial world does the Wheelchair Technologist profession exist in? How can we expect a profession that does not exist in the industrial world to be developed in developing countries?
- Response: when dealing with prosthetics and orthotics education in developing countries there was a similar situation. Many industrial countries did not have Category-II and III prosthetics/orthotics personnel. Neither does CBR exist in industrial countries. Only 2 or 3% of people have access to rehabilitation services. Need to train Wheelchair Technologists to address needs. Also do not have a problem with brain drain. Need to be looking into the future to work towards 10 years time so wheelchair technology becomes as accepted as prosthetics and orthotics is now. Not just talking about one approach. Talking about a series of approaches, and Wheelchair Technology is just one.
- Long-term vision to respect human rights for every individual with a disability. Developing countries trying to develop their own strategies, policies and standards. Right moment to plan properly. More cost effective in the end.
- Sense of overall picture of personnel that we need to train is missing. Need to train people from referral end up to specialist Wheelchair Technologist. Would be helpful to get a clear picture of roles that are envisaged to see what training is required.

- In the scope of the programme we need to look at many solutions, and there are a number of options.
- Uganda experience: formerly very little information was there. However, after Wheelchair Technologist training the government was sensitised and had a stakeholder conference. There is now a difference in awareness.

4. There is a need for guidance in distributing wheelchairs to the service provider. What areas should be covered? Are there any requirements that can be specified?

- Clarification required on part on distribution based on suggestion from distributor.
- What are the responsibilities a distributor has before following up?
- Distribution should be based on database to stop unnecessary donations. Should be more specific to avoid bringing in more wheelchairs than necessary. Add to the criteria used by distributors that there should be collaboration with people working in wheelchair provision.
- Distributor should be aware of existing standards in country.
- Worldmade: when looking for service partner would make an assessment to see whether they have staff suitable to train in service provision. Being members of the organisation responsible for service delivery makes for more sustainability.
- Comprehensive guidance list. Is this document good to include in consensus?
- Felt should be national coordination body to collect data of wheelchairs being distributed to establish needs. Everyone should register with central office to feed in needs to weed out 'professional wheelchair recipients'.
- Extensive list, some of the points listed are the duty of governments and local authorities. Government has final authority on what comes into country and is given to the population.
- Guidelines for government seem to be missing. Unless they are spelled out the government might not take them up. How does the government or agency in the country monitor distribution? Can the government turn down a distributor and on what basis?
- In Cambodia there are many wheelchairs from outside with no follow-up. How do they know what is happening to the wheelchairs in Cambodia. Many spare parts are broken and nobody cares. Group attempted to say it should be the in-service partner.
- Important to create network between service providers donators and government. There are instances when you may want to not deal with government because of bureaucracy to accomplish goals.

CONFERENCE PAPERS

Needs, poverty and inclusion: Needs, human rights access

**Chapal Khasnabis
WHO, Geneva, Switzerland**

The global disabled population is increasing due to population growth, ageing, emergence of chronic conditions such as cancer, diabetes and cardiovascular diseases and injuries caused by road-traffic accidents, landmines, war and violence.

Many of these disabled people need a wheelchair. Mobility is a birthright – it is necessarily a fundamental right, and people have a right to have a wheelchair. For many who are unable to walk independently, a wheelchair provides mobility. With an appropriate wheelchair, one can exercise freedom of movement. Independent mobility can make it possible to study, work, participate in cultural life, and access medical care, leading to inclusion and equal participation.



Benefits of having a wheelchair

An appropriate wheelchair is beneficial for the physical health of the user. It decreases common health issues such as pressure sores, the progression of deformities or contractures, and other secondary conditions, resulting in reduction of health care expenses. It facilitates improved respiration, digestion, and better posture. All these results lead to increased activity levels and a better quality of life.

Wheelchairs make a difference

An appropriate wheelchair can change a disabled person's situation from:

- Isolation to inclusion,
- Dependency to freedom,
- Passive receiver to active contributor.

Children can go to school and adults can make an income, and people will often live longer when using an appropriate wheelchair. However, despite of all these advantages, the majority of disabled people cannot afford to have a wheelchair.

Poverty and disability

The unique and strong linkage between poverty, illiteracy, poor healthcare, disability and exclusion is well established. Poverty increases disability, and at the same time, disability enhances poverty. People living in poverty are more likely to acquire disability than others. In any community, often the poorest of the poor are people with disabilities and their family members. People with disabilities and their family members have fewer opportunities and are deprived of basic human rights. The majority of people will prioritise day to day living over buying or getting a wheelchair.



Access

In many developing countries, only 2-5% of population who are in need of rehabilitation services, can access it. Among rehabilitation services, one of the neglected areas is wheelchair or mobility devices. Many developing countries have very little capacity to produce wheelchairs and mostly depend on foreign donation. The majority of donated wheelchairs fail to match individual needs or survive in the environment where majority live.

The standard rules on the equalization of opportunities for persons with disabilities

Twenty-two rules have been adopted by the United Nations General Assembly, Forty-eighth Session, 1993.

Rule 4: Support services as preconditions for equal participation

States should ensure the development and supply of support services, including assistive devices for persons with disabilities, to assist them to increase their level of independence in their daily living and to exercise their rights.

- States should ensure the provision of assistive devices and equipment.
- States should support the development, production, distribution and servicing of assistive devices and equipment and the dissemination of knowledge about them. Persons with disabilities themselves could be involved in the production of those devices.
- States should recognize that all persons with disabilities who need assistive devices should have access to them as appropriate, including financial accessibility. This may mean that assistive devices and equipment should be provided free of charge or at such a low price that persons with disabilities or their families can afford to buy them.

UN convention on the rights of persons with disabilities

Article 3: General principles

- (a) Respect for inherent dignity, individual autonomy including the freedom to make one's own choices, and independence of persons;
- (b) Non-discrimination;
- (c) Full and effective participation and inclusion in society;
- (d) Respect for difference and acceptance of persons with disabilities as part of human diversity and humanity;
- (e) Equality of opportunity;
- (f) Accessibility;
- (g) Equality between men and women;
- (h) Respect for the evolving capacities of children with disabilities and respect for the right of children with disabilities to preserve their identities.

Article 4: General obligations

States: Parties undertake to ensure and promote the full realization of all human rights and fundamental freedoms for all persons with disabilities without discrimination of any kind on the basis of disability.

State's responsibilities:

- To undertake or promote research and development of, and to promote the availability and use of new technologies, including information and communication technologies, **mobility aids, devices** and assistive technologies, suitable for persons with disabilities, giving priority to technologies at an affordable cost (g)
- To provide accessible information to persons with disabilities about **mobility aids, devices** and assistive technologies, including new technologies, as well as other forms of assistance, support services and facilities (h)

Article 20: Personal mobility

States: Parties shall take effective measures to ensure personal mobility with the greatest possible independence for persons with disabilities, including by:

- (a) Facilitating the personal mobility of persons with disabilities in the manner and at the time of their choice, and at affordable cost;
- (b) Facilitating access by persons with disabilities to quality mobility aids, devices, assistive technologies and forms of live assistance and intermediaries, including by making them available at affordable cost;
- (c) Providing training in mobility skills to persons with disabilities and to specialist staff working with persons with disabilities;
- (d) Encouraging entities that produce mobility aids, devices and assistive technologies to take into account all aspects of mobility for persons with disabilities.

Article 26: Habilitation and rehabilitation

States: Parties shall promote the availability, knowledge and use of assistive devices and technologies, designed for persons with disabilities, as they relate to habilitation and rehabilitation.

Article 32: International cooperation

States: Parties recognize the importance of international cooperation and its promotion, in support of national efforts for the realization of the purpose and objectives of the present Convention, and will undertake appropriate and effective measures in this regard, between and among States and, as appropriate, in partnership with relevant international and regional organizations and civil society, in particular organizations of persons with disabilities.

Such measures could include capacity building including exchange and sharing of information, experiences, training programmes, transfer of technology and best practices.



Steps for consideration

There is a need to address the issues related to poverty and wheelchairs with equal focus. A rights based approach is important: the right to have a quality wheelchair, to empower the person with disability to decide and choose and to facilitate greater access to wheelchairs. In order to develop a sustainable wheelchair provision system better data and research is needed showing the impact of good wheelchair provision to the individual, to the family and the country.



Appropriate wheelchairs

Appropriate wheelchairs should be three 'A's

- Available
- Accessible
- Affordable

Appropriate wheelchairs should meet *the needs of the USER not the GIVER....*

Needs poverty and inclusion: User participation

Venus M Ilagan
Disabled Peoples' International (DPI), Quezon City, Philippines

Introduction

Persons with disabilities, especially those living in the developing countries, are widely acknowledged to be the poorest of the poor. The majority of them are dependent on their families and other people for their survival. While some persons with physical disabilities can be mobile and economically independent, they are often unable to work because of the lack or unavailability of assistive devices such as wheelchairs, which they need for their mobility.

People with disabilities remain at the bottom of the income distribution ladder in every country of the world. In developing countries, they are among the poorest of the poor. With an estimated 400 million disabled people living in developing countries, this population outnumbers most marginalised groups. They are important as consumers, producers, taxpayers, beneficiaries, and citizens, yet they have been largely absent from thinking about poverty reduction and economic development.

On many occasions, Judy Heumann, former disability advisor of the World Bank, has clearly pointed out that the two key issues of disability and development are discrimination and poverty.

The eradication of poverty among persons with disabilities will not and cannot be achieved without first addressing their mobility needs. It is also necessary to mainstream disability issues in all development policies and ensure that disabled persons are engaged in the planning, design, implementation and evaluation of development programmes targeted for them. But before disabled persons can participate in the development activities of their communities, their mobility requirements must first be addressed. There is no point in talking about economic development in relation to persons with disabilities without first addressing their mobility needs.

Overwhelming need for wheelchairs

The need for wheelchairs is extremely high in the developing countries. According to a report from the Whirlwind Wheelchair International, 20 million people in developing countries are acutely in need of wheelchairs for their mobility but less than one percent of them own or have access to these devices.

The demand for affordable, high-performance and durable wheelchairs designed to withstand the rough urban and rural conditions in the developing countries remains a challenge for those who are sympathetic or concerned about the situation of poor disabled persons in the poorest countries of the world.

Wheelchairs donated by charitable, religious or humanitarian organisations hardly address this need because often, the donated wheelchairs are of poor quality, not tailor-made for the requirements of the user, not fit for the harsh conditions in the developing countries and often do little to contribute to the socio-economic integration of people with disabilities into their communities.

Ralf Hotchkiss of Whirlwind Wheelchair International has identified the problems associated with the current production and distribution of wheelchairs in developing countries:

1. *Donated wheelchairs are usually not appropriate for conditions in developing countries*
Most imported wheelchairs are based on American and European designs from the mid-20th century for indoor home and institutional use. These designs were not intended for outdoor use on unpaved terrain. They break easily, but are not easily repaired because parts are not usually available locally.

2. *There are no widely accepted appropriate standards to ensure quality*
With some exceptions, wheelchairs donated or sold in developing countries are often sub-standard. Those that are of better quality are designed for the developed countries, which are not stringent enough to adequately test chairs under the harsher conditions and use in developing countries.
3. *There are no prescription or fitting standards*
Donated and imported chairs are often “*one size that fits all*”, and are often distributed without cushions or an appropriate sitting configuration. A wheelchair without a cushion or an appropriate sitting configuration may increase the risk of secondary conditions such as pressure sores, shoulder injuries or spinal deformity.
4. *There are few training programmes that teach the proper prescription, fitting and use of wheelchairs*
Wheelchairs that are donated under charitable programmes are often delivered without any training on how to properly match the wheelchair user to his/her new appliance through assessment, prescription and fitting. Nor is training provided to the user to ensure adequate working knowledge of the capabilities and limitations of the chair.
5. *Wheelchair users remain passive recipients of charity rather than empowered consumers*
Since wheelchair users in developing countries most often, cannot afford to pay for their own wheelchairs, government agencies, development organisations, and charitable and religious institutions act as consumers instead. The usual market forces of consumer-based supply and demand are absent; end users are disenfranchised from the design, production and selection processes and remain passive recipients of charity rather than empowered consumers. They are unable to affect the quality and variety of the goods and services they need.

Wheelchair production by persons with disabilities: the Philippines’ experience

KAMPI, the national federation of organisations of persons with disabilities in the Philippines, has been a recipient of used reconditioned wheelchairs from developed countries for many years. KAMPI receive the donated chairs and distribute these to pre-identified beneficiaries from its membership. But these chairs have not been durable enough to withstand the difficult conditions in areas where the recipients live. Often, when the wheelchairs break, they can no longer be repaired and have to be thrown away. Their parts are not readily available in local bicycle stores: a broken frame cannot be welded because the material used is not often compatible with materials which local welders use; the size of the wheels are not available in ordinary bicycle stores, including the front or caster wheels.

In a bid to produce wheelchairs made of locally available raw materials which can be sold at more affordable prices to enable more users to have increased mobility, KAMPI, through its affiliates, has embarked in wheelchair production and sale in the early 1990s. However, persons with disabilities who have gone into this initiative as a livelihood activity could not compete with the extremely low prices of wheelchairs supplied by manufacturers in China and Taiwan. Government entities and non-government organisations, the major providers of wheelchairs to pre-identified recipients, preferred to buy their supply from importers rather than patronise the products of organisations of persons with disabilities. But the cheap imported wheelchairs are often made of very poor quality materials and they come in sizes that rarely fit the user/consumer.

Just like the fate of many other disability organisations in the Philippines who have attempted to produce wheelchairs, very few of the KAMPI affiliates who have gone into this type of a livelihood project have succeeded in maintaining their operations. Many of them have instead shifted into the production of school chairs which are sold more easily to government-owned schools.

Disability as a socio-economic issue

Often, governments and donor agencies and institutions see disability as only a matter of impairment and personal mobility which can be solved with giving away wheelchairs. What

they do not readily understand is the fact that disability is a part of life which has social, cultural, political and economic implications, not a medical emergency that can be solved with the number of wheelchairs that can be given away. They fail to see what people with disabilities can accomplish by having these chairs in terms of accessing education and employment to enable them to earn their own incomes, have families, and take part in the life and activities of their communities.

Disability and development: a paradigm shift

During the last two decades, however, there emerged new models of looking at disability. Persons with disabilities have started to be seen as full members of society who have important contributions to make to their families and communities if only they are provided with the support they need to be productive. This shift in thinking is often referred to as the “social model” of disability. It sees disability as the interaction between a disabled person and the environment.

This model emphasises that persons with disabilities are prevented from realizing their full potentials not because of their impairment, but as a result of legal, attitudinal, architectural, communications and other discriminatory practices. This perspective is concerned principally with identifying, exposing and examining the limitations imposed on persons with disabilities by the physical and social environments in which they live, including the lack of support for their mobility. Over the years, persons with disabilities have likewise sought to combat traditional perceptions of them being objects of charity or sick people in need of cure.

The social model of disability, combined with a rights-based approach recognises persons with disabilities as rights-holders who can and should determine the course of their lives to the same extent as any other member of society. It also defines limitations imposed by the social and physical environment as infringements on disabled peoples’ rights.

The World Bank defines *‘inclusive development’* in relation to persons with disabilities, as a process that ensures that all phases of the development cycle (design, implementation, monitoring and evaluation) include a disability dimension and that persons with disabilities are meaningfully participating in development processes and policies. It also implies a rights-based approach to development that is firmly grounded in international human rights standards and focused on the promotion and protection of human rights.

In other words, inclusive development (i) ensures that persons with disabilities are recognised as rights-holding, equal members of society who must be actively engaged in the development process irrespective of their disability or other status such as age, race, sex, ethnicity and religion; and (ii) that development institutions, policies and programmes must take into account and be assessed in accordance with their impact on the lives of persons with disabilities, and consistent with the promotion of internationally recognised human rights.

The recent adoption by the UN Ad Hoc Committee of the Convention for the Rights of Persons with Disabilities is a great opportunity for the sector. However, it is important to realise that there are some other initiatives which must not be side-lined as they are equally important in facilitating the equalization of opportunities for all disabled persons.

I would underscore what seems to be a limited corresponding effort addressed to the economics of disability and development. Until today, disability advocates often single out discrimination as the root cause of poverty among disabled persons. Research on the dual casualty between disability and poverty has been weak, and the weakness has been compounded by poor information exchange. Disability groups in developing countries lack economic expertise, and they have not yet developed a persuasive case for including disability in development thinking on economic grounds. With the absence of data and domestic interest groups who can effectively advocate disabled peoples’ right to economic development, governments in developing countries have tended to ignore disability as a development topic.

In most countries, there are no national disability statistical indicators to begin with. While it is widely accepted that people with disabilities are among the poorest of the poor in every given

society, research on poverty and disability is rare and there is widespread exclusion of disabled persons within the work of development and research organisations. Internationally, comparative statistics relating to disabled people and poverty are lacking.

When the issue of disability and development are addressed in developing countries, it is usually in relation to foreign aid. Yet foreign assistance has tended to implement narrowly-focused enclave projects which were proved unsustainable when attention moves to other countries. Take the example of East Timor. The country which was ravaged by years of conflict used to receive so much attention from the international donor community. But when the effort and priorities shifted to Afghanistan, to Iraq, and recently to victims of Tsunami in countries in South Asia as well as the earthquake which killed and disabled thousands in Pakistan and India, efforts related to disability in East Timor almost all came to a halt.

As long as disability is treated solely as a specialist issue and not included in mainstream development work, the exclusion and hence, the poverty that characterise the lives of a huge majority of persons with disabilities will not be addressed.

As a starting point, disability issues should be considered explicitly as human rights and social development issues. In practice, this means that the disability dimension has to be included and considered in all development co-operation initiatives to ensure equal rights for disabled persons to participate and benefit from all development undertakings. It also means that poverty alleviation activities must take into account the poorest of the poor, often people with disabilities, by making every effort to include disabled people in the development agenda of the United Nations, its specialised agencies and development finance institutions.

Conclusion

In conclusion, I wish to go back to my earlier statement that the first step towards the economic independence of wheelchair users as a group of persons with disabilities is to provide these devices which are extremely needed for their mobility; users in developing countries need wheelchairs that are strong enough to withstand difficult manoeuvring over rugged terrains, light in weight, portable, durable and affordable. Only when these are provided can persons with disabilities live productive, meaningful and self-fulfilling lives and be able to participate and contribute to the development of their communities.

References

Hotchkiss R. 2003. Social and political issues involved in meeting AT needs abroad: the Whirlwind example. A workshop offered at the LADTC Forum.

Whirlwind Wheelchair International, Motivation and Center for International Rehabilitation. 2006. Proposal to develop standards for wheelchair provision services

Heumann J. 2004. Global partnership for disability and development: concept paper. Washington: The World Bank.

Lord JE. 2002. Understanding the Role of an International Convention on the Human Rights of People with Disabilities: An Analysis of the Legal, Social, and Practical Implications for Policy Makers and Disability and Human Rights Advocates in the United States. White Paper. Washington: US National Council on Disability.

Mont D. 2004. Disability employment policy. Social Protection Discussion Paper Series: No 0413. Washington: The World Bank.

Needs, poverty and inclusion: Approaches to wheelchair provision from USAID's perspective

**Lloyd Feinberg
USAID, Washington, USA**

Goal

Sustainable approaches to ensuring maximum accessibility to social, economic and political opportunities for war victims and other persons with disabilities:

- Promotion of cost effective approaches to production, delivery and distribution (open to and all approaches that contribute to this goal.)

Historical background

USAID's Leahy War Victims Fund was initiated in 1989 primarily in response to concerns about victims of landmines and other consequences of armed conflict:

- Began with focus on prosthetics:
 - Narrow focus based on appreciation of complexity and breadth of issues facing prosthetic users and providers
 - LWVF supported direct service delivery, capacity building and expanding the knowledge base.
- When significant progress had been achieved in the prosthetics area, USAID/LWVF expanded into related areas, orthotics, accessibility, wheelchairs, etc.,
- Significant interest and investment in wheelchair production began in the late 1990s with support for some local design and manufacturing and training (TATCOT/Motivation programme). (Earlier USAID support was provided to Ralf Hotchkiss in the early 1980s.)
- USAID/LWVF investment strategy seeks to accommodate the desire to provide chairs for the tremendous numbers of people in need of wheelchairs in less developed countries, while endeavouring to ensure that the chairs are appropriate.

Investment strategy consists of:

- Direct provision of devices and services
- Strengthening local capacity:
 - Institutional strengthening
 - Human capacity development (training)
- Strengthening the knowledge base:
 - Design
 - Production
 - Assessment
 - Delivery and distribution

Two critical questions:

- How to ensure that maximum number of people needing wheelchairs can have access to chairs that meet acceptable standards.
- Does the provision of free imported chairs and/or uncontrolled subsidization of chairs adversely affect the emergence and growth of viable, local producers and suppliers?

Two major concerns:

- "Do No Harm"
 - Ensure that chairs do not pose health or safety threats to users

- Ensure that activities do not impede the growth and health of potentially sustainable producers and sustainability
- Sustainability
 - Viable business models
 - Financial
 - Managerial
 - Technical

USAID/LWVF expectations from the conference:

- Open, professional and responsible discussion of issues:
 - Do not let the pursuit for perfection interfere with the search for practical progress
- Statements and standards representing consensus on most critical issues

Review session: Review of literature on wheelchairs for developing countries & Review of wheelchair provision in developing countries

**Jon Pearlman
University of Pittsburgh, Pittsburgh, USA**

Abstract

A range of literature has been written related to wheelchair design and delivery in developing countries; these include newspaper and magazine articles, newsletters from various groups working in the industry, and peer reviewed publications (e.g. conference abstracts, books, reports, and journal articles). To this end, we present the literature categorized in the following literature categories: design, research, reviews, and related articles. Related articles are indirectly related to this topic either because they address related issues in less-resourced environments (e.g. clinical issues related to wheelchair usage, or other assistive devices), or they address wheelchair design and failure but in more resource-rich environments. Much of the literature here was passed on from others in the field and is not catalogued in typical literature indexes; we assume that there are other articles that were not brought to our attention, or that we could not find. Additionally, while many of the articles presented here are from international conferences and/or journals, only English-language literature is presented here; we assume that there are non-English sources.

Introduction

We have catalogued roughly forty abstracts, articles, books and other print media that relate to wheelchair design and provision in less-resourced environments. This collection of literature is by no means comprehensive, but instead represents a sample of the types of literature that has addressed this topic over the past several decades. Much of the information on this topic is presented through means of newsletters and the websites of the various organizations working on these projects. Some of these organizations have also published literature in peer-reviewed journals and at conferences. A few research abstracts and articles have been published which report on outcome studies and/or the results of structured research and development projects. There are large bodies of literature that are related to wheelchair provision in these environments, either because they discuss similar technology or healthcare issues relevant to wheelchair users in these regions, or issues of wheelchair provision in more resource-rich environments that are relevant to other environments. Finally, several review articles are written that address wheelchair provision in specific regions, or the field in general (which discuss several of the aforementioned articles).

Rather than repeat the information presented in the review articles, we have made an effort to categorize the literature to better organize the type of information that has been published. Definitions for the categories and grading scale are presented in the next section, followed by a summary of literature, and a conclusion section.

Operational definitions

The following categories have been defined for the literature:

Wheelchair design literature presents wheelchair designs and/or highlights positive or negative aspects of particular designs.

Research articles are systematic, repeatable studies which investigate outcome parameters (such as quality of life, or wheelchair durability) of wheelchair provision or demographic variables. Additionally, these studies can be well-documented research and design articles (so long as they are described to the degree that they can be repeated).

Review articles bring together many topics or articles related to wheelchair provision in less-resourced environments. These articles may be a systematic review of articles relevant to the topic of wheelchair provision in these countries. Additionally, they can be articles about a particular location (e.g., Mexico) which highlight the important factors to consider when

providing wheelchairs. Finally, these articles may discuss a wide range of projects or issues in several regions (but not necessarily integrate other literature). We have organized these articles in the subcategories: Whirlwind Wheelchairs International Articles, Narratives, Literature Reviews, and Case Studies.

Related articles do not specifically address wheelchair provision in less-resourced environments, but present relevant information. For example, they could include articles which discuss similar technology (e.g., prostheses) in these environments, or health issues such as pressure ulcers. Furthermore, they could discuss wheelchair technology and provision issues in other environments, such as wheelchair quality testing, which are relevant in all environments. Note that there is a large body of arguably relevant literature; only a selection of them has been presented.

Literature review

Wheelchair design

Most of the articles in this review have discussed, to some degree, aspects of wheelchair design. Specific designs (with varying degrees of detail) have been described by many authors.

Independence through mobility (Hotchkiss 1985) may be the most comprehensive design and manufacturing guide. Several other articles by Whirlwind International (WWI) have discussed the design in varying degrees (Hotchkiss 1993; Hotchkiss 1987; Pfaelzer 1998; Jeserich 2003) and the designs are freely distributed by WWI. Additionally, two books (*Disabled village children*, and *Nothing about us without us* (Werner 1987; Werner et al. 1998) include instructions on building wood wheelchairs.

As mentioned in many references, the design of the first durable wheelchair for less-resourced environments is attributed to Dr. R.L. Huckstep who designed the wheelchair in the 1960s in Uganda (Huckstep 1975). Designs for this three-wheeled wheelchair are widely available online.

Design briefs and descriptions are also widely available through the websites and newsletters of organization performing this work.

Research articles

In *Third world wheelchair manufacture: will it ever meet the need* (Hotchkiss and Knezevich 1990), the authors use the population of wheelchair users in the United States to project to approximate the world need for wheelchairs: 20 million in 1990 and a projected 24 million in 2000. This paper is one of the most widely referenced in terms of determining need. Note that it does not take into account the failure rate of wheelchairs (i.e., they are expected to last only 5 years) and also, the usage rate of wheelchairs has risen in the US; thus the paper presents a conservative estimate of the need.

In *Wheelchair charity: a useless benevolence in community-based rehabilitation* (Mukherjee and Samanta), the authors presents the results of an outcome study of depot wheelchairs donated to users in West Bengal, India. The results demonstrate that the majority went unused (57.4%) and many were sold (14.2%). Only 7.4% were used regularly; the remaining were used occasionally (10.5%) or were attendant propelled (10.5). Rejection of the wheelchairs was attributed to habitat adaptability (34%), pain fatigue and discomfort (28.6%), frequent damage (15%), upper limb issues (11.6%), and inability to drive (10.7%). This study is the first and only of its kind to report the outcome of these devices in a systematic way. While the authors do not report the important information, such as the duration of time the devices were used/unused, it is a strong first step in research in this area.

In *Study of wheelchair operations in rural areas covered under the District Rehabilitation Centre (DRC) scheme* (Saha et al. 1990), the authors present the results of a survey of wheelchair recipients (n=60) from two DRCs in India. Major findings are that a minority of users self-propelled (~10%) and most were attendant propelled (~50%). Wheelchairs were predominantly used outside the home because of accessibility issues, and many of the users

complained of problems with casters and fears related to the stability of the wheelchairs (60%).

A series of research articles were published describing the systematic approach taken for needs-assessment, design, and evaluation of a new mobility device for women in India through a collaboration between Queen's University in Ontario, Canada, and the National Institute of Design in Ahmedabad, India. In the first article Mulholland and co-authors (1998) describe the results of an exploratory research project to collect data about the demographics, environment, current mobility and seating strategies, activity of daily living, and sociocultural information of 10 women with disabilities in India. This data confirmed other Saha's suggestions (Saha et al. 1990) that users perform many tasks low to the ground, and inspired a wheelchair design focused on this need. In the second paper Lysack and co-authors (1999) describe the design process for the 'Gadi' mobility device, which included an iterative process of designing, prototyping and evaluating the device. In the final paper, Mulholland et al. (2000) presents the feedback from 8 women who evaluated the Gadi mobility device in India. Each subject used the device for approximately 20 minutes and using a feedback interview. Overall response to the device was positive, although the subjects provided a wide range of recommendation about the device. This range was in part attributed to the small sample size, and justifies the need for more research and the importance of consumer involvement in the design process.

Review articles

Whirlwind Wheelchairs International Papers

Project 2020: reports on various international meetings to meet the global need for wheelchairs by 2020:

- *Notes from Sri Lanka meeting* cover a range of goals setup in 1998 (agenda items) including wheelchair guidelines, QOL evaluations, wheelchair costing, etc. It was attended by Handicap International (HI), Whirlwind International (WWI), and Motivation.
- *Report on consultative meeting on international support for production of wheelchairs in developing countries* covers the main introduction, the meetings, and action items, including need for coordination, collaboration and alliances; ideas that work with the UN is ideal; agreed that 20 million wheelchairs by 2020 is necessary.
- *Notes on open discussion during consultative meeting (May 5th)*: highlights included recognition of requirements for multi-level policy; the idea that technical issues are no longer the problem (i.e., good wheelchair designs are there) but more that business and marketing skills and models is the most critical element to solve. Other technology is necessary to distribute with wheelchairs (e.g., sliding board etc)
- *All-Africa wheelchair builder's congress – a huge success* (Krizack) highlights the work of several wheelchair factories around Africa, and covers issue of wheelchair testing, new designs, and concerns of large-scale distributions of wheelchairs in Africa.

Groundswell on wheels (Hotchkiss 1993), provides a biography of the Whirlwind Wheelchair and highlights the common maintenance problems with poorly designed and manufactured wheelchairs. The review also discusses WWI design framework of integrating the designs from workshops worldwide. Hotchkiss also writes that through the 24 workshops opened, over 10,000 wheelchairs have been build thus far. An important example given was in Malawi, where a large-scale donation put one of his manufacturers out of business.

Building wheelchairs, creating opportunities (BWCO) (Hof et al. 1993) provides an overarching view of the needs and supply of wheelchairs worldwide, and the desperate need to ramp up production to meet the need. The BWCO was a programme coordinated with several organizations to rapidly increase the wheelchair production worldwide, as well as providing local jobs for People With Disabilities (PWD) and others in the community. The document also covers the risks and dangers of mass production (referring mostly to Everest & Jennings) and one-size-fits-all wheelchairs (inappropriate, not repairable, etc.) The authors suggest that small and large-scale manufacturers should be in the market to meet the both the need for high volume, and customized wheelchairs (like the bicycle market in India). The

authors also cover several case studies to highlight the need for durability testing, reasonable financing solutions, and relevant design features (e.g., x-braces.)

Narratives

The international transfer of appropriate assistive technology (Stone 1993) covers the various types of technology transfer that occur (person to person; professional-community-PWD; country to country). Stone successfully argues that a 'bottom-up' approach is necessary, where the end-users (PWD, DPOs etc.) are ultimately in control of the technology transfer: they demand knowledge (e.g., how to build devices), or the technology itself. This approach is related to Community Based Rehabilitation and ideas of Demand-Pull Technology transfer (Lane 1999).

Rural rehabilitation technologies for the disabled In developing countries (Desai 1984) presents a range of important factors to consider when developing or distributing technology in less-resourced countries, including: consumer characteristics (users' right to decide what is best, and the fact that technology must be designed to meet the users particular needs); aspects of living such as the strong link between poverty and disability, and the limited social and health support for PWD; service delivery models (institutional, integrated, community-based) arguing that community based is most successful (for individuals with blindness). The author also argues that every nation setup a policy for PWD to advocate and protect their rights; that staff training is critically important, and that affluent countries should assist to setup small model projects, and clearing houses to disseminate knowledge, experience and expertise.

Appropriate assistive technology (Zollars and Ruppelt 1999) discusses how appropriate technology can 'foster independence in everyday personal and community function activities...' She highlights the importance of user-centred design, and the failures of mass produced (new or refurbished) devices. Finally, she maps out the important factors which need to be considered when making the devices appropriate: person's functional requirements, environment & climate, aesthetics, available materials, and durability.

In *Technology for the disabled* (James 1984) the author discussed the increased prevalence of assistive devices, and compares the devices widely produced in wealthy countries, to those needed in less-resourced environments. The author argues for more appropriate technology and 'regional training centres that would take account of the local environment and local needs and customs.' While this article seems to stress issues related to prosthetics, the scope is wide enough to include wheelchairs.

David Werner has published a wide variety of literature on the virtues of community based rehabilitation, including the importance of providing appropriately designed and fit wheelchairs to individuals. The most comprehensive discussion of this is within his books (Werner 1987; Werner 1992; Werner et al. 1998) and newsletters.

Literature reviews

Seating/wheelchair technology in the developing world: need for a closer look (Kim and Mulholland 1999) is a thorough literature review of this topic. Its main points are that that literature and research in the seating and mobility area is abundant, except with respect to developing countries, where literature is usually qualitative (narratives for example, etc.). The authors discuss issues of 'western donations' of depot and/or used wheelchairs failing, and the need for appropriate sustainable devices. They also discussed the importance of needs-assessment prior to design and/or delivery of a wheelchair, community-based involvement, user-involvement, benefits of local production, consideration of cultural and psychosocial issues, and the importance of a team approach when providing wheelchairs and seating.

In *Towards the development of an effective technology transfer model of wheelchairs to developing countries* (Pearlman et al 2006) the authors provide a brief literature review and present examples of the most common technology transfer strategies. The paper presents a framework for comparing these different transfer modes, and also makes suggestions on other potentially fruitful transfer modes.

Technical and clinical needs for successful transfer and uptake of lower-limb prostheses and wheelchairs in low income countries (Pearlman et al. In Press) is a literature review of wheelchair and lower-limb prostheses (LLP) provision in less-resourced environments. The authors compare and contrast the devices, arguing that LLP technology and provision is much more standardized and appropriate, due in part to the past research and development efforts, and best-practice guidelines. The authors further suggest research that would allow feedback on how to streamline and improve the quality of wheelchair provision.

Case studies

In *Ten years of rehabilitation technology in a developing country: a review 1980-1990* (Boonzaier 1990) discussed the outcome of transferring western techniques and technologies to South Africa. He suggests that welfare programmes and donated technology have been 'relatively unsuccessful in making any real impact.' In relation to wheelchairs, he writes 'wheelchair(s), as used in North America (are) totally useless in the rural settings' and are 'reduced to scrap within one year of rigorous use.' The author argues that community-based projects and appropriate technology are the way to resolve these issues.

In *Advancement of appropriate rehabilitation technology in Indonesia* (Carson 1994) the author uses case studies to try to 'identify the core characteristics of rehabilitation technology (device assessment, design, fabrication) influenced by the culture, society and economic conditions in Java, Indonesia...' The author highlighted the failure of a bamboo wheelchair because the material was considered to indicate poverty. Additionally, the author discussed the drawback to text-book type learning that was promoted for the clinicians. Finally, Carson highlighted various elements to ensure the device is appropriate, including suitability for the users' needs in their cultural and community environments, suitability of materials, affordability, training (for service providers), simplicity of the design, feedback about the device performance.

While there are typically case-studies presented in newsletters, they are too numerous to mention here, although it is realized it may be the largest volume of data on the subject. Also, this information can be subject to bias, since the organizations writing and publishing this information are generally trying to promote their projects.

Related articles

In *Life-cycle analysis of depot versus rehabilitation manual wheelchair* (Cooper et al. 1996) the authors use ISO testing to compare the durability of depot (institutional) and rehabilitation wheelchairs (adjustable, light-weight) and find that the low durability of depot chair results in the wheelchairs costing 3.4 times as much to operate. This was calculated by normalizing the wheelchair cost by the number of durability testing cycles the wheelchair survived. This presents a compelling argument to provide higher quality wheelchairs in all countries. Similar arguments are made in related articles (Fitzgerald et al. 2002).

In *Wheelchair safety-adverse reports to the United States Food and Drug Administration* (Kirby and Ackroyd-Stolarz 1995) the authors present the number of injuries and fatalities attributed to tips and falls of wheelchair and scooter riders. Seventy five percent of the 368 injuries were related to tips and falls, and most were attributed to engineering problems (poorly designed wheelchairs). This highlights the importance of stability in wheelchair design.

In *A follow-up program in India for patients with spinal cord injury: paraplegia safari* (Prabhaka and Thackker 2004) the authors report the results of a follow-up evaluation of individuals treated in their hospital. Follow-ups were done by trying to locate the original 787 patients: 447 were ultimately visited, 282 could not be found, and 58 patients had died (7.4%). Of those 58 patients, 22% had died from septicemia as a result of pressure ulcers. This paper highlights the danger of pressure ulcers and thus the importance of pressure-relieving cushions.

No mean feet (Singhal and Nundy 2004) is a short biography of Dr. Sethi and his invention of the Jaipur Foot. While there are several articles written about this project, this publication succinctly describes the outcome when inappropriate technology (in this case, prosthetic

limbs, feet, and braces) is provided (abandonment) and the solution: using local craftsmen to develop technology that was culturally, socially, and environmentally appropriate.

Conclusions

There are very few published designs in the literature. The downfall of this is that it may require any new organizations interested in producing and delivering wheelchairs to rely on the few published wheelchair designs, or design their own wheelchair. From the current theme in the field, most organizations design their own wheelchair. In some cases, while organizations have not published their designs, they are happy to provide the designs free of cost. Project 2020 suggests that the technical barriers (design, materials, etc.) have been overcome. If this is indeed the case, it may be prudent to freely distribute those designs so that organizations new to the field do not begin the product development process from the initial stages.

Very few research articles are published in this field. The two outcome study articles published suggest that there is poor durability and a high abandonment rate for hospital-style wheelchair users. While the results are convincing, the studies suffer from potential for bias and this limited amount of data is not sufficient to draw overall conclusions about which types of wheelchairs are most appropriate to provide. More research is necessary to answer this important question. Likewise, the R&D series of articles are a strong first step to standardizing the method of assessment, design, and testing of new wheelchair devices; more publications on this process are necessary.

The bulk of the articles reviewed here were narrative or review articles. A similar theme of information came from nearly all of the papers, which was the support for a bottom up, or user-centred design approach. A strong emphasis was on the user's involvement in the design, production, and choice of their wheelchair was discussed in many papers. This was supported by several negative experiences published regarding western technology and techniques failing in the field. There was also support for focus in the field on service delivery, training, and sustainability. Also, need for more research was mentioned by several authors.

Related research articles were chosen in their relation to the anecdotal or research data reported on wheelchair service delivery for developing countries. Main points include that wheelchair injuries are commonly caused by tips and falls from the wheelchair, and that the vast majority of those tips were attributed to engineering problems with the wheelchairs; this provides a convincing argument to focus on wheelchairs stability in the design of a wheelchair to promote safety. Evidence was also presented that low-cost wheelchairs are not necessarily a better value: results suggest that hospital-style wheelchairs may cost over 3 times as much in comparison to rehabilitation-style wheelchairs. Also shown through a research study was the high rate of mortality due to pressure-ulcers by individuals with spinal injuries.

References

Boonzaier DA. 1990. Ten years of rehabilitation technology in a developing country: a review 1980-1990. In: RESNA 13th Annual Conference, Washington DC.

Carson MC. 1994. Advancement of appropriate rehabilitation technology in Indonesia. In: RESNA '94, Nashville, Tennessee.

Cooper RA, Robertson RN, Lawrence B, Heil T, Albright SJ, Van Sickle DP, Gonzalez J. 1996. Life-cycle analysis of depot versus rehabilitation manual wheelchairs. *J Rehabil Res Dev* 33:1:45-55.

Desai MA. 1984. Rural rehabilitation technologies for the disabled in developing countries. In: International Conference on Rural Rehabilitation Technologies, Grand Forks, N Dakota.

Fitzgerald SG. 2002. Comparison of fatigue life for 3 types of manual wheelchairs. *Arch Phys Med Rehabil* 82:10:1484.

- Hof H, Hotchkiss R, Pfaelzer P. 1993. Building wheelchairs, creating opportunities: collaborating to build wheelchairs in developing countries. *Technol Disabil* 2:2:1-14.
- Hotchkiss R. 1985. Independence through mobility: a guide to the manufacture of the ATI-Hotchkiss wheelchair. Assistive Technology International.
- Hotchkiss R. 1993. Ground swell on wheels: appropriate technology could bring cheap, sturdy wheelchairs to 20 million disabled people. *The Sciences* July/Aug.
- Hotchkiss R. 1987. Putting the tools in the hands that can use them: wheelchairs in the third world. In: RESNA 10th Annual Conference, San Jose, California.
- Hotchkiss R, Knezevich J. 1990. Third world wheelchair manufacture: will it ever meet the need? In: RESNA 13th Annual Conference, Washington DC.
- Huckstep R. 1975. Poliomyelitis: a guide for developing countries. Edinburgh: Churchill Livingstone.
- James WV. 1984. Support services. In: World Health Forum. Geneva: World Health Organization. pp 256-258.
- Jeserich M. 2003. Building appropriate chairs for the developing world. *Assist Technol J*: Jan 15.
- Lane JP. 1999. Understanding technology transfer. *Assist Technol* 11:1:5-19.
- Kim J, Mulholland SJ 1999. Seating/wheelchair technology in the developing world: need for a closer look. *Technol Disabil* 11:1-2: 21-27.
- Kirby RL Ackroyd-Stolarz SA. 1995. Wheelchair safety-adverse reports to the United States Food and Drug Administration. *Am J Phys Med Rehabil* 74:4:308-312.
- Lysack JT, Wyss UP, Packer TL, Mulholland SJ, Panchal V. 1999. Designing appropriate rehabilitation technology: a mobility device for women with ambulatory disabilities in India. *Int J Rehabil Res* 22:1:1-9.
- Mukherjee G, Samanta A. 2005. Wheelchair charity: a useless benevolence in community-based rehabilitation. *Disabil Rehabil* 27:10:591-596.
- Mulholland SJ, Packer TL, Laschinger SJ, Lysack JT, Wyss UP, Balaram S. 2000. Evaluating a new mobility device: feedback from women with disabilities in India. *Disabil Rehabil* 22:3:111-122.
- Mulholland SJ, Packer TL, Laschinger SJ, Olnet SJ, Panchal V. 1998. The mobility needs of women with physical disabilities in India: a functional perspective. *Disabil Rehabil* 20:5:168-178.
- Pearlman JL, Cooper RA, Zipfel E, Cooper R, McCartney M. 2006. Towards the development of an effective technology transfer model of wheelchairs to developing countries. *Disabil Rehabil: Assistive Technology* 1:1-2:103-110.
- Pearlman JL et al. In Press. Technical and clinical needs for successful transfer and uptake of lower-limb prosthetics and wheelchairs in low income countries. *IEEE-EMBS Magazine*.
- Pfaelzer P. 1998. Whirlwind network news: advancing wheeled mobility worldwide 98. In: Wheelchair production in developing countries: some observations. Whirlwind Wheelchair International: San Francisco State University.
- Prabhaka M, Thackker T. 2004. A follow-up program in India for patients with spinal cord injury: paraplegia safari. *J Spinal Cord Med* 27:3:260-262.

Saha R, Dey AK, Hatoj M, Poddar S. 1990. Study of wheelchair operations in rural areas covered under the district rehabilitation centre (DRC) scheme. *Indian J Disabil Rehabil* 1990:74-87.

Singhal D, Nundy S. 2004. No mean feet. *BMJ* 328:3 April: 789.

Stone JH. 1993. The international transfer of appropriate assistive technology. *Technol Disabil* 2:2:15-18.

Werner D. 1897. *Disabled village children: a guide for health workers, rehabilitation workers, and families.* Hesperian Foundation.

Werner D. 1992. *Where there is no doctor.* Hesperian Foundation.

Werner D, Thuman C, Maxwell J. 1998. *Nothing about us without us.* Palo Alto: HealthWrights. p350.

Whirlwind. Project 2020: Reports on various international meetings to meet the global need for wheelchairs by 2020 (cited 2006; available at: <http://www.whirlwindwheelchair.org/>)

Zollars JA, Ruppelt P. 1999. Appropriate assistive technology. In: 1999. *Cross-cultural rehabilitation: an international perspective.* Edited by Leavitt RL. London; Philadelphia: WB Saunders. pp 125-136.

Review session: User satisfaction survey: an assessment study on wheelchairs in Tanzania

Tone Øderud¹, J Steen Jensen², John E Lyimo³, Abdullah Munish⁴ & Paul Shunda⁵

¹**SINTEF Health Research, Norway**

²**ISPO, Copenhagen, Denmark**

³**Kilimanjaro Christian Medical Centre (KCMC), Moshi, Tanzania**

⁴**Wheelchair Workshop, KCMC, Moshi, Tanzania**

⁵**TATCOT, KCMC, Moshi, Tanzania**

Background

There are few publications about the provision of wheelchairs to people with disabilities in developing countries (Pearlman et al. 2006) today. On initiative from World Health Organization (WHO), the International Society for Prosthetics and Orthotics (ISPO) organised an assessment study of wheelchairs and wheelchair service provision in order to provide background information for the ISPO Consensus Conference on Wheelchair Technology for Developing Countries, November 2006 in Bangalore, India.

Method

The assessment study including the data collection was carried out the first week of October 2006 in the Kilimanjaro region in Northern Tanzania. The assessment team consisted of two orthopaedic surgeons, one wheelchair technologist and user representatives, one prosthetist-orthotist and one researcher.

The total of 47 persons with disabilities using mobility devices such as wheelchairs and tricycles were included in the study. The informants were recruited from the members of Kilimanjaro Association of Spinally Injured (KASI) (29), from Monduli Rehabilitation Centre (2), from Arusha Vocational Training Centre (3) and on an individual basis (13). All the informants were interviewed by the assessment team using the same protocol with more than 50 questions, based on the validated system; Wheelchair skills Test-Q, version 2.4 (Mountain et al. 2004; Kirby et al. 2004). The protocol included personal information, user experiences, demographic data, and information on wheelchair provision, wheelchair performance, and clinical assessment.

In addition to interviewing all the informants, visits to Monduli Rehabilitation Centre, Arusha Vocational Training Centre, KASI and home visits (5) were carried out during the week of data collection.

Findings

Out of the total number of informants; 79% were male and 21% were female. The age profile varied from 11 years up to 56 years with a median of 31 years. The major causes of disability among the informants were spinal cord injury (62%), neurological (21%) and infections (15%). Some 62% were paraplegic, 28% were quadriplegic and 6% were affected by polio. Only 2% were affected by cerebral palsy. Since the majority of the informants were recruited from KASI, it was expected that there would be a high number of spinal cord injured, being either paraplegic or quadriplegic.

The onset of disability varied from birth to the age of 53 years; 62% of the informants had their disability before the age of 20 years.

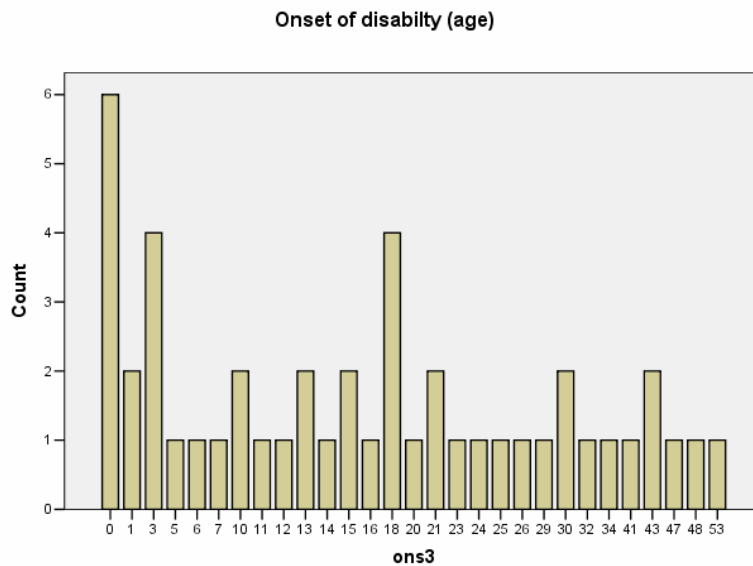

Figure: Onset of disability by age



Figure: Time between onset of disability and the first delivery of wheelchair

The local environment where the informants were living was almost equally distributed between urban areas with paved roads and rural areas with unpaved roads. The distance from the house to the main road was varying from 0 m up to 3000 m, with the median of 300 m. About half of the informants could push themselves in their wheelchair for a distance of 1000 m; 23% were unable to move by themselves more than 50 m.

The employment rate of the informants is relatively high, in comparison with data available from living conditions in Namibia, Malawi and Zambia; 28% were unemployed, 36% were skilled workers, 26% were unskilled workers and 8% were students/children. Some 56% were living with their family or partner, and 23% were living alone.

The total numbers of informants were 47 and the total numbers of mobility devices (wheelchairs and tricycle) included were 52 devices. Five (5) informants had two mobility devices.

Numbers of different types of wheelchairs and tricycles:

- 3-Wheeler: 20 (38%)
- 4-Wheeler: 28 (54%)
 - Hospital Wheelchair: 21
 - Locally made 4-Wheeler: 5
 - Sports Wheelchair: 2
- Tricycles: 4 (8%)

More than half of the informants used their wheelchair for the whole day. The minimum number of hours that the informants spent in the wheelchair per day was 2 hours and the maximum was 16 hours. The median was 10 hours per day.

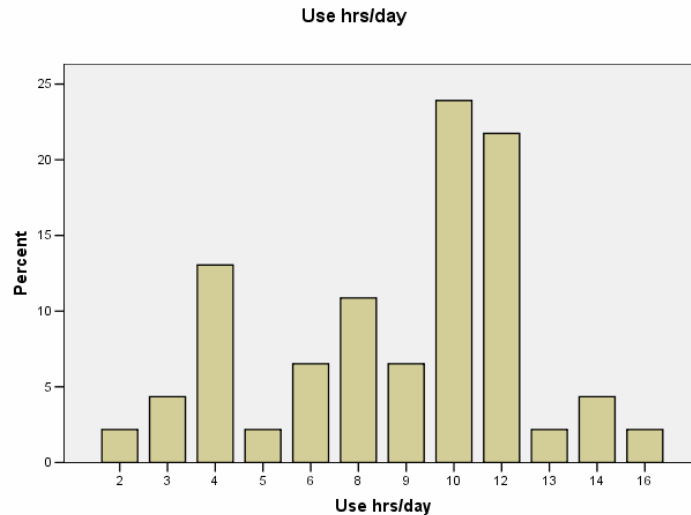

Figure: Number of hours spent in the wheelchair daily.

About 60% of the wheelchairs were funded by non-governmental organisations (NGOs), and about 40% were funded by charity organisations.

Some 60% of the wheelchair was prescribed by a trained wheelchair technologist. If the wheelchairs were split into to groups; one group of locally made wheelchairs and one group of donated charity wheelchairs, there are significant differences identified. All locally made wheelchairs were prescribed by trained wheelchair technologists, while for the charity programmes about 40% of the wheelchairs were prescribed by trained personnel.

Prescription		Wheelchair source		Total
		Locally made	Charity	
OT	Count	0	3	3
	% within charity	0%	13%	6.3%
PT	Count	0	1	1
	% within charity	0%	4.3%	2.1%
WCT	Count	25	5	30
	% within charity	100%	21.7%	62.5%
Other	Count	0	5	5
	% within charity	0%	21.7%	10.5%
None	Count	0	9	9
	% within charity	0%	39.1%	18.8%
Total	Count	25	23	48
	% within charity	100%	100%	100%

Figure: The percentage of locally made and donated charity wheelchairs prescribed by occupational therapists, physiotherapists, wheelchair technologists and others.

All locally manufactured wheelchairs were reported to be individually fitted to each individual person, but only 35% of the wheelchairs provided from charity programmes were reported to be individually fitted to each person.

% within wheelchair source		Wheelchair source		Total
		Locally made	Charity	
Fitting	Individual fitting	100%		52.1%
	New fit. check		26.1%	12.5%
	Used fit. check		8.7%	4.2%
	Used self selection		65.2%	31.3%
Total		100%	100%	100%

Figure: The percentage of locally made and donated charity wheelchairs that are individually fitted to each person

During the study, the seat width of the informants and the seat width of their wheelchairs were measured. For these calculations the seat was defined to be too broad if the width was greater than the seat width of the person plus 4 cm. In many countries it is recommended to add just 2-3 cm to the seat width of the person in order to be acceptable. Almost 60% of the donated charity wheelchairs were too broad for the user, while the corresponding figures for locally made wheelchairs were 30%.

Seat width		Wheelchair source		Total
		Locally made	Charity	
OK	Count	14	8	22
	% within WC source	58.3%	38.1%	48.9%
Broad	Count	7	12	19
	% within WC source	29.2%	57.1%	42.2%
Narrow	Count	3	1	4
	% within WC source	12.5%	4.8%	8.9%
Total	Count	24	21	45
	% within WC source	100%	100%	100

Figure: The size of the wheelchair seat with reference to the size of the wheelchair user for locally made and donated charity wheelchairs

All the informants was asked if they were provided with training on how to manoeuvre the wheelchair, how to transfer from wheelchair to bed, toilet, other chairs, etc. and how to care for and carry out minor maintenance and repairs. Some 92% of the informants that received a locally made wheelchair from the local workshop reported that they received a training programme. Only 35% of the informants that received a donated charity wheelchair from a charitable organisation (rehabilitation centre, church, individual friends, etc) received a training programme.

% within source		Wheelchair source		Total
		Locally made	Charity	
Fitting	Yes	92.0%	34.8%	64.6%
	No	8.0%	65.2%	35.4%
Total		100.0%	100.0%	100.0%

Figure: The percentage of informants receiving training with reference to local made wheelchairs and donated charity wheelchairs.

Some 92% of the informants receiving local made wheelchairs were satisfied with the seating comfort of their wheelchairs, while 68% of the informants receiving donated charity wheelchairs were satisfied with the seating comfort.

			Wheelchair source		Total
			Locally made	Charity	
Comfort	Very satisfactory/ satisfactory	Count	23	15	38
		% within WC source	92.0%	68.2%	80.9%
	Unsatisfactory/ very unsatisfactory	Count	2	7	9
		% within WC source	8.0%	31.8%	19.1%
Total	Count	25	22	47	
	% within WC source	100%	100%	100%	

Figure: The percentage of informants' satisfaction with reference to local made wheelchairs and donated charity wheelchairs.

Discussion and conclusions

It was reported that the locally made wheelchairs were more suited to the local environment than the donated hospital style wheelchairs. Some of the characteristics of the different types of wheelchairs are summarised in the following:

- Charity/hospital wheelchairs
 - Suited for indoor use and paved ground, not for local/rural area
 - Easy transportable when using private cars or public transport
- Local made 3-wheeler
 - Suited for rural area and longer distances
 - Not easily transportable, but the quick release wheels facilitate and enables transport using private cars or public transport
- Local made 4-wheeler foldable
 - Suited for local area
 - Easy transportable when using private cars or public transport
- Tricycle
 - Suited for travelling long distances
 - Not suited for indoor use

It was reported to be very difficult to locally repair and maintain donated hospital wheelchairs, and there is a lack of spare parts for donated wheelchairs. Many of the users of donated charity wheelchairs were not able to have their wheelchair repaired:

- Donated/charity wheelchairs
 - Very difficult to repair locally
 - Lack of local available spare parts and repair facilities
- Locally made wheelchairs
 - Easy to repair locally
 - Local available spare parts and repair facilities

The service delivery process including assessment, prescription, individual fitting, training, and service and repair of the wheelchair were studied. The parameters identified were significantly better for the group that received their wheelchairs through local workshops involving trained local wheelchair technologists than the group receiving their wheelchairs through charity programmes.

Some 60% of the charity wheelchairs were distributed without professional prescription, and 74% of the charity wheelchairs are provided with no technical assistance, while all the locally made wheelchairs were prescribed and provided by trained wheelchair technologists; 65% of the charity wheelchairs were given to the user without individual fitting.

Some 60% of the charity wheelchairs are given to the user without training, while 92% of the local made wheelchairs are given to the user with training

The wheelchairs provided by charity programmes had generally too wide seats (57%) and were rarely provided with a cushion. The wheelchairs provided by charity programmes gave

more frequently discomfort in sitting; 32% of the users of charity wheelchairs are not satisfied with the seating comfort, while 8% of the users of local made wheelchairs are not satisfied with the seating comfort.

It is a need for local structures facilitating a service delivery system providing wheelchairs and services for people with disabilities. Wheelchairs are assistive devices and should be provided, individually fitted and followed up by trained personnel.

Recommendations

Although the numbers of informants interviewed were limited the conclusions were clear. There is a lack of appropriate structures for assessment, prescription, fitting, training, etc with reference to donated/charity wheelchairs. "One model/size does not fit all" and there is a need for different wheelchair models that will facilitate individual fitting and appropriate postural support.

It is recommended that similar studies are carried out in other countries or regions.

Furthermore it is recommended that guidelines are produced for a service delivery system providing wheelchairs and services to people with disabilities. These guidelines should also include recommendations for local available repair and maintenance availability.

Donors/charity organisations should be recommended to collaborate with existing local partners and buy from adequate local workshops where existing.

References

Kirby RL, Dupuis DJ, MacPhee AH, Coolen AL, Smith C, Best KL, Newton AM, Mountain AD, MacLeod DA, Bonaparte JP. 2004. The Wheelchair Skills Test (version 2.4): measurement properties. *Arch Phys Med Rehabil* 85:794–804.

Mountain AD, Kirby RL, Smith C. 2004. The Wheelchair Skills Test, version 2.4: validity of an algorithm-based questionnaire version. *Arch Phys Med Rehabil* 85:416–423.

Pearlman J, Cooper RA, Zipfel E, Cooper R, McCartney M. 2006. Towards the development of an effective technology transfer model of wheelchairs to developing countries. *Disabil Rehabil: Assistive Technology* 1:103 -110.

Plenary discussion: Needs, poverty and inclusion & Review session

Chair: J Steen Jensen
Rapporteur: Sarah Sheldon

There was a point of clarification that the term 'depot' wheelchair means the same as 'hospital' wheelchair.

Bardsley: Only broad figures of need for wheelchairs are available. However, the estimate of 20 million people who need a wheelchair and do not have one is now under doubt. Without more detailed awareness it is difficult to develop systems to meet their needs. It was asked whether WHO would work towards giving more accurate figures

Khasnabis: WHO are trying their best, however it is difficult to collect data as disability is not a priority within WHO. WHO has recently passed a resolution in World Health assembly regarding data and in 2009 a report on disability will be published. WHO hopes within the report they will be able to give a better picture on the real needs of disabled people. However, data collection is time consuming and not an easy or cheap process. WHO is looking at gathering data on Road Traffic Injuries and resulting in Spinal Cord Injury. There will be a better picture in 2009.

Jensen: Noted that WHO supported a census in El Salvador but it has not been analysed yet.

Khasnabis: DAR only has a small team within WHO and is trying to recruit an epidemiologist. It has taken a long time to mainstream disability within WHO and they now need to begin to develop tools to give information on numbers of wheelchair users.

Cornick: One of the points both Ilagan and Khasnabis made clear is that mobility is a human right. Many people have suffered from international donors looking at wheelchair provision as service provision and not as a right. This message is not getting through to donors. Is there anything that can be done to support this?

Khasnabis: Everything takes time and it has been a struggle to get assistive devices within the UN convention. Within the disability movement the needs are quite varied and many of the powerful groups do not understand the importance of wheelchairs. However Article 20 is very important and once the convention is ratified the disability movement needs to unite to lobby governments to support the convention. Wheelchairs are now becoming an interesting subject.

Jensen: It was interesting to see in Pearlman's review that the wheelchair users' right to influence their prescription is now included in academic literature.

Ilagan: Some good practice has developed, but there is not enough sharing. I would like to encourage donors to support knowledge sharing. Also East Timor used to get a lot of support, however, now the priority has shifted to Afghanistan and Iraq, so initiatives in East Timor have almost ground to a halt.

Jensen: Donors often look for publicity show what they are doing. However, no one is interested in follow-up. There is a need to pressurise NGOs to follow-up their practice. Would it be in the interest of DPI to initiate follow-up to see whether assistive devices really fulfil demand?

Horvath: In the survey carried out in Tanzania the conclusions only addressed locally made and charitable wheelchairs. Why was this? Also, with the small sample size there seemed to be insignificant differences, but conclusions were still drawn.

Øderud: There is a desire to analyse the survey in more detail, and the number is not significant. It was surprising that wheelchairs could be divided into locally-made and

charitable-made and it was chosen to bring forward these two areas as a background to the debate.

Jensen: From a scientific point of view, in the prosthetic feet studies ISPO have conducted over the years where there were limited numbers of subjects, it was possible to draw conclusions through linking the different studies. We hope to be able to make further surveys of wheelchair outcomes.

Horvath: It was striking that 47% of locally made and prescribed wheelchairs still did not fit.

Jensen: There seemed to be a lack of check-out control. Øderud noted that the survey did not go deeply into the quality of the fitting and the figures are only an indication.

Curtis: I am struck by how my own experience was reflected in the study. The results were not a surprise as they reflected different organisational goals of a distribution system and a wheelchair business. However, it was a surprise that local wheelchairs were not fitted better.

Jensen: Less attention should be paid to organisational interests than the fitting of the wheelchair user as it is pointless to deliver thousands of harmful wheelchairs.

Hodge: Many people prefer to have a wheelchair that does not fit than no wheelchair at all and queried whether the end user should describe what they want or whether they should be told what they need. The goal of individual fitting is not attainable and although it is possible to discuss best case scenario ideals, the reality is that with large scale donations the donor is not afforded many options.

Hotchkiss: It is difficult to balance wheelchair users' own perception of what they need with clinical advice and noted that only 8% of people thought their wheelchairs fitted badly.

Scheffler: Care should be taken when saying that donated products are not wanted. She raised the issue that a cooperative relationship with donors is necessary to ensure charitable chairs are being fitted properly. Some 40% of wheelchair users at Western Cape Rehabilitation Centre need very customised wheelchairs and they need to explain this to donors in order to get more appropriate products to offer to clients.

D Nanda: Did the survey consider how long people had used the wheelchairs for and the durability before the first repair was required?

Øderud: Some data has been gathered but not analysed yet. There are no figures on the onset of first repair that wheelchair users do not remember.

Jensen: All the wheelchairs surveyed were delivered within the previous one or two years but people had not been back even if they needed repairs as they did not have the funds.

Services:

Referral, assessment and prescription, fitting, basic user training (including peer group training)

Chapal Khasnabis & Federico Montero

Disability and Rehabilitation Team (DAR), WHO, Geneva, Switzerland

Introduction

Historically disability has been viewed by society as a tragic and life ending event. Persons with disabilities in particular have been viewed by society as powerless and voiceless. Denied access to basic services and participation in society, disabled people become isolated and are often discriminated against.

However, recently there have been a number of changes in the disability field. These include new international standards, legal instruments, participation of persons with disabilities themselves in meeting disabled people's needs, improvements in professional competence, rehabilitation technology and the training of personnel. All of these changes point to a positive change in the way disability is viewed by society.

Referral: health and rehabilitation

In developing countries wheelchairs are distributed through a number of means. Wheelchair users often receive their wheelchairs through distribution camps or events. Other organisations involved in wheelchair provision are:

- CBR programme
- NGOs/DPOs
- Tertiary centres or referral care facilities
- Teaching/training institutes

Mainstreaming of wheelchair services

The existing methods of wheelchair provision are not coordinated. Planned services involving integration of wheelchair services with other existing rehabilitation services is desirable as wheelchair services would be enhanced by integration with other national health and rehabilitation services where possible. Integration helps coordinate efforts among key stakeholders, make best use of existing resources such as health centres and staff, and facilitate strong referral and consulting networks.

Referral networks

Referral networks play a crucial role in wheelchair service provision. Well functioning referral networks help to ensure services are accessible to wheelchair users. Referral networks in each country may consist of Government, NGO or DPO, health and rehabilitation personnel working at community, district or regional level. The challenge is how to reduce the gap between wheelchair policy makers, manufacturer, provider and user; how to take wheelchairs from referral facilities to the community.

The role of referral network personnel

Within wheelchair service provision there is a key role for referral network personnel. Their responsibilities are varied, but include:

- Identification and referral of people requiring wheelchairs,
- Liaison between the wheelchair user, their family, and the wheelchair service to facilitate assessment, fitting and follow-up appointments,
- Reinforcing wheelchair service training such as pressure sore prevention, prevention of secondary complications, wheelchair maintenance and skills for mobility,
- Providing support, advice and possibly assistance in the adaptation of the wheelchair user's home environment; and encouraging measures in the community to facilitate accessibility,
- Provision of information to the wheelchair service about the acceptance and use of prescribed wheelchairs,
- Assisting the wheelchair user to arrange repairs to wheelchairs,

- Promotion of the benefits of wheelchairs.

Assessment, prescription, fitting and training

Assessment, prescription, fitting and training, all need to be an integral part of wheelchair provision. Preferably, each wheelchair user should receive an individual assessment by a person trained to do so. Using the information gained from the assessment a wheelchair prescription can be developed. The prescription usually lays out the details related to wheelchair type, size, special features, and modifications.

Roles of users and prescribers

Historically wheelchairs have been prescribed with a vertical approach; professionals prescribing wheelchairs with little involvement by the wheelchair users themselves. However, there have been changes in attitudes of those prescribing wheelchairs towards a more shared approach in recent years. Ideally, the core role of a wheelchair service includes working with the wheelchair user to carry out an assessment to facilitate the user to identify and choose the most appropriate wheelchair which will suit individual as well as environmental needs.

Cushion, postural support/adaptations

Wheelchairs often need to be adapted to suit the wheelchair user. Most users will need some form of postural support and cushioning. All wheelchair users with a spinal cord injury will need a pressure relieving cushion. The lack of these adaptations can cause complications, reducing performance of the wheelchair user and limiting their participation in society. In the worst cases lack of support or cushioning can reduce a wheelchair user's life span

Different ages/different conditions

It is important for those involved in wheelchair provision to be aware of conditions related to age. Capabilities of wheelchair users change with ageing. Assessment should take into consideration the wheelchair user's physical condition; home, school, work and other environments of use; lifestyle; size and age.

Fitting

Fitting is a critical step in the process of wheelchair provision. At the fitting, the wheelchair user and rehabilitation personnel ensure that the wheelchair fits correctly and supports the wheelchair user as intended. During fitting, the wheelchair user and staff together check that:

- the wheelchair is the correct size,
- the wheelchair is correctly adjusted for the wheelchair user,
- any modifications or postural support components are fitting correctly, and the wheelchair is meeting the wheelchair user's mobility and postural support needs.

Basic user training including peer group training

Training is an integral part of the wheelchair service provision. The wheelchair user and, where appropriate, care-givers are given instruction on how to safely and effectively use and maintain their wheelchair. For active wheelchair users, it is ideal if this training is provided by a wheelchair user (peer trainer). Ideally, every wheelchair recipient should receive peer group training which definitely influences and makes a difference to their quality of life.

Peer group support

Peer group support, the support of wheelchair users by other wheelchair users, should be promoted amongst wheelchair users and their families. Peer group support can:

- Improve capacities to carry out activities of daily living
- Advise on necessary improvements in the home environment
- Give support to cope with changes in personal relationships.

Conclusion

Appropriate wheelchair provision is not only a matter of designing, producing, providing and maintaining wheelchairs, it also demands honesty and long-term commitment. Appropriate wheelchair provision must always focus on meeting the needs of the USER not the GIVER.

Services:

Follow-up, service and maintenance (including repairs and maintenance), sustainability of service, service delivery system

Abdullah Munish

Wheelchair Service, Kilimanjaro Christian Medical Centre, Moshi, Tanzania

Wheelchair service in Kilimanjaro, Tanzania

I am Abdullah Munish and work with the Kilimanjaro Christian Medical Centre (KCMC), Orthopaedic Department as a Wheelchair Technologist.

In Tanzania there is a great need for wheelchairs to assist people with disabilities. The majority of clients who need wheelchairs in our setting are people with spinal chord injury, cerebral palsy, stroke, polio and others. Donated wheelchairs are not suitable wheelchairs users due to the local environment and they frequently break down, requiring repairs and often needing spare parts which are not available. By understanding this situation faced by wheelchair users in our region, medical professionals from different departments such as the Orthopaedic, Physiotherapy, Occupational Therapy and Surgical Departments came up with a proposal of establishing a Wheelchair Committee within KCMC to work on issues related to fabrication, service delivery, distribution and maintenance.

In 1996, the KCMC Wheelchair Committee was established with its three main objectives, one of which was to develop the wheelchair production and repair workshop at the hospital.

Later, in 2001, one of the first graduates from the new Wheelchair Technology Training Course (WTTTC) being taught at the Tanzania Training Centre for Orthopaedic Technologists (TATCOT) was employed by KCMC to establish the wheelchair workshop in order to produce appropriate wheelchairs to suit the local terrain and also to carry out repair work.

The objectives of the KCMC Wheelchair Committee were successfully met and the workshop is continuing to provide a wheelchair service within the region and other parts of Tanzania.

The different aspects of wheelchair service activities are carried out by a wheelchair service professional e.g., fabricating the wheelchair in the workshop, preparing seating cushions, assessing and taking measurements from users, and running our outreach assessment programme.

Wheelchair provision

There are important procedures to follow in the provision of wheelchair in KCMC:

Referral: Referrals are received from doctors, occupational therapists, physiotherapists, Disabled People's Organisations (DPOs) as well as self-referrals.

Assessment: A physical assessment is then carried out, the socio-economic status of the patients and their living environment is also considered. Measurements are taken in order to fabricate a wheelchair that will fit the user.

Payment: We also have to find out who is going to pay for the wheelchair. Even if the person cannot pay after finishing the assessment we send the information to the Technologist and Technicians to fabricate the wheelchairs as there are other possibilities of financial support; in particular through the Kilimanjaro Association of the Spinally Injured (KASI).

Fitting and adjustment: After the assessment process, an appointment is given to the client on a date to come for the fitting and adjustment. If the wheelchair needs adjustment, which can take some days, a second appointment is given. This is very rare as most of the wheelchairs made in KCMC need only one fitting. This is a very important part of the provision of the

wheelchair because if it is not done properly it may cause complications for the user for a few days.

Quality control and issue: Finally, before the wheelchair is issued, we carry out quality control checks on the wheelchair to see if all the modules of the wheelchair are working properly.

Personnel

In the workshop there are four people, one of whom is a wheelchair user, who has been trained as a peer trainer. He provides training to wheelchair users on how to handle the wheelchair, transfer techniques, how to avoid getting pressures sores and how to make small repairs to the wheelchair. This is also a very important activity as it will not only help to improve the wheelchair user's quality of life, but also can encourage them to join a DPO in order to know more about disability issues.

KCMC Wheelchair Workshop believe that it is very important to promote the social model of disability rather than medical model which medical professionals were promoting for many years and which is believed has resulted into disabled people losing their self-esteem and confidence.

Wheelchair service is about quality of life; without the possibility of socializing in the community, and society understanding the problems faced by disabled people, especially wheelchair users, the need for wheelchair services will still be questionable to stakeholders. The only thing which will change this situation is promoting the social model within our services.

In most circumstance in this world, if any kind of service is being provided, there will also be some follow-up to see if the service delivered has met the desired goals.

In the KCMC service, a follow-up is conducted but it is not performed by the wheelchair service personnel; it would be a costly activity to carry out and the funds are not available to carry such activity. Instead a link has been established with Rehabilitation Centres and DPOs within the region. These Rehabilitation Centres have outreach programmes whereby we send our technicians once a month or after three months to follow-up our clients in order to find out the performance of the wheelchair which was issued. All the findings are documented for reference.

The repairs and maintenance carried out by the workshop are for major breakdown and if modifications are required to be done.

As mentioned earlier, wheelchair users are trained to do minor repairs themselves. The areas which the workshop repairs or deals with most often are:

- Rear and front wheels
- Spokes
- Changes of the tyres
- Greasing
- Changes of the bearings
- Wheelchair and seat cushion maintenance
- Who to contact in the case of problems or need for repairs

The wheelchair users are given information on who to contact in case of any problems or need for repairs.

The delivery system used is not too complicated, the procedure is followed from the first day we meet with the clients. An appointment is made to come for fitting and after a further appointment to collect his/her wheelchair. For the Rehabilitation Centre and DPO clients the wheelchair is sent to the particular organisation for delivery but during the fitting and hand-over, we are always be there to make sure that all processes are carried out properly and if there is any adjustment to be done in the workshop, we return it for adjustment and modification.

Since wheelchair production started in 2002, the sustainability of the workshop has depended on revolving funds from the wheelchairs we sell and funds from donors and international organisations. KCMC Hospital has been very helpful to the workshop by providing salaries for workshop staff, paying electricity and water bills. Most people with disabilities are the poorest of the poor, and hence cannot afford to pay for a mobility aid. There is very limited funding for wheelchairs, and understanding such a challenge, the wheelchair workshop has collaborated with the Kilimanjaro Association of the Spinally Injured (KASI) to establish a wheelchair financing committee with the aim to find funds from different donors from within and outside the country to help those who cannot afford to pay for a wheelchair. It has been a successful activity to date and many disabled people have benefited from this committee. For the long-term solution it is indeed important that the Tanzania Government plays a big role through the Ministry of Health and Social Welfare. If the government will not contribute to this service, it is unclear how wheelchair services provided by local workshops will remain sustainable; but I am happy with the wheelchair financing system we have for the moment, we are still sensitizing and lobbying the Government of their responsibility for paying for assistive devices, I do hope that in the coming two or three years the Government will be able to give such support.

Services:

Community based services: Mobility India

Albina Shankar
Mobility India, Bangalore, India

Background

Bangalore, with an estimated metropolitan population of 6.1 million, has about 400 officially notified slums. These slums co-exist with well-developed areas, as is the case in other big cities. Most of these areas have large deficiencies in water supply, environmental and sanitation infrastructure. It is estimated that about 20% of Bangalore's population live in slums.

This disadvantaged section of our society has to bear additional costs of disability. The physical and attitudinal barriers and the additional financial costs they incur in order to manage their disability are a few dimensions of their hardship. The problems are augmented, the challenges and costs they face become often unmanageable.

Mobility India (MI) was set up in Bangalore, South India, in 1994 to reduce the wide gap between the need and availability of rehabilitation services (www.mobility-india.org/services) in rural areas and urban slums. MI is a good example of a team where people with disabilities are involved at all levels.

Community involvement is a key to success

MI's community based rehabilitation programme (CBR) was started in 1999. Its main objective was to promote an environment in which both disabled and non-disabled children are encouraged to go to school, obtain an education and therefore greater opportunities in life. The key focus was to involve those with disabilities and their parents, by setting up self-help groups. MI supported the groups to set up income generating schemes which were relevant to the local community and ensure their children could go to school. Hence MI's strategy has been to put people with disabilities at the centre of the rehabilitation process with the primary aims being to both poverty and education issues.

The programme has been able to draw extensive support from the local community, local government, elected representatives and other organizations (e.g., NGOs, hospitals) in Bangalore. MI's technical and training resources have been employed to develop and implement effective and appropriate rehabilitation plans for all children and adults with disabilities in the project area.

Initially, in our enthusiasm to make a difference in the lives of people with disabilities, our rehabilitation plans and interventions were focused on providing rehabilitation services. To improve this, the human resources (CBR workers, Therapy Assistants, Therapists, Technicians) were developed and equipped at different levels to address the needs of wheelchair users as well as people with other mobility impairments especially in providing the best affordable and available wheelchairs; the results being easily tangible and greatly visible but only in the long-term so it makes very little difference if the core issues are not addressed at the same time. The core issues are poverty, health and education. From the lesson learnt our role has evolved. The person with a disability, self-help group and the community are now at the centre and are seen in a much broader context and aimed at addressing the wider causes and consequences of disability.

Our experiences of implementing CBR programmes have highlighted the fact that social exclusion and lack of access to basic services such as education, livelihood, and healthcare disable a person more than his/her impairment. In addition, people with disabilities and their families are often the most marginalised in their community. They can live a life with little aspiration or hope. In our experience, CBR approach can make a positive and lasting impact on both the person with a disability and the community because it addresses health and rehabilitation services with equal attention to education, income generation, participation and inclusion.

MI's strategy is aimed at creating a society which includes people with disabilities. MI aims to create an environment where people with disabilities are able to exercise their rights of equal access to medical, educational and livelihood opportunities.

Nine years of work in the Bangalore slums has resulted in greater visibility of people with disabilities in the community. Disabled children are now going to school; disabled adults gainfully employed; the employment of field staff who has personal experience of disability and above all active participation of community members in MI's growth. MI and the community are working together for change and an equal society.

Services:
DPO based services: Disabled Women's Support Organisation, Zimbabwe

Gladys Charowa
Disabled Women's Support Services, Harare, Zimbabwe

The Disabled Women Support Organisation (DWSO) is registered as a Private Voluntary Organisation and was formed and registered as a trust in 2003 in Zimbabwe. Its mission is to physically and economically empower women and girls with disability.

The organisation has 1063 members from all ten Zimbabwean provinces; all of whom are women and girls, most of these are wheelchair users, and approximately 600 have a spinal cord injury.

The director of DWSO, Gladys Charowa, sustained a spinal cord injury on 29 April 2002. She underwent rehabilitation along with 19 others at Ruwa Rehabilitation Centre, just outside of Harare. However, following their discharge, by 30 September 2002 she was the only survivor of the group of 19.

In order to find out the cause of these deaths, Gladys began to work together with the health advisor to the Zimbabwean president. She wanted to investigate why people with spinal cord injuries in Zimbabwe were dying within 2 years of their injury. In contrast those who sustain a spinal cord injury in industrial countries have a normal life expectancy. They discovered that contributing factors to limited life expectancy were:

- Lack of information about spinal cord injury and how to avoid secondary complications
- Inappropriate wheelchairs
- Non-acceptance of disability.

To attempt to bridge this gap DWSO was formed.

DWSO carries out many activities in order to improve the quality of life of women and girls with spinal cord injuries in Zimbabwe. One of their main activities is offering peer group support which includes:

- Peer counselling
- Assistance with locating of appropriate wheelchair
- Education of wheelchair users in independent living skills
- Bowel and bladder management and skincare
- Wheelchair skills and maintenance
- Education of family members and caregivers.

DWSO also undertakes weekly visits to rehabilitation centres and hospitals, and home visits to those isolated in their own houses. The organisation carries out HIV/AIDS awareness activities, as HIV/AIDS is an issue that affects many of DWSO's members. Disabled people are at high risk from HIV/AIDS, but are often excluded from mainstream HIV/AIDS initiatives.

DWSO is involved in lobbying the government and advocating for the provision of appropriate wheelchairs, disability devices and urinary equipment for people with spinal cord injuries within Zimbabwe. Finally the organisation helps its members initiate income generating projects countrywide, an essential activity given the current economic climate of Zimbabwe.

It is sad to note that during 2006 a total of 261 of DWSO's members died. Their deaths were from various causes, but the most common were:

- HIV/AIDS
- Complications caused through the use of inappropriate or ill fitting wheelchairs
- Infections caused through the lack of availability of urinary management equipment.

The need for wheelchairs in Zimbabwe is rapidly increasing due to the HIV/AIDS pandemic. People who develop AIDS often develop tuberculosis of the spine, resulting in the loss of mobility. A number of organisations are involved in importing and distributing donated wheelchairs, however, these wheelchairs generally arrive in country and are distributed without the knowledge of local Disabled People's Organisations (DPOs). This means that the wheelchair users do not get the support of DPOs, and as DPOs are not consulted during the distribution process the wheelchair users are often given inappropriate wheelchairs which are not suitable for the terrain and do not last. Wheelchairs are being distributed without assessment or prescription, and wheelchair users are not given adequate information about how to use their wheelchair, which can lead to secondary complications, for example pressure sores and scoliosis.

In September 2006 DWSO participated in planning a Zimbabwe Wheelchair Stakeholders' Workshop. This was a two-day workshop designed to gather all stakeholders in wheelchair provision in Zimbabwe to identify the issues faced by wheelchair users and to try to develop a strategy for improving the provision of wheelchairs in the country.

The stakeholder workshop was attended by:

- Ministry of Health and Child Welfare
- Disability Board
- DPOs
- World Health Organisation
- Wheelchair Donors
- Local NGOs
- International Donors
- Wheelchair Technologists.

The group made four main recommendations as a result of the workshop:

1. DPOs should take a leading role in wheelchair provision
2. DPOs should work with service centres in the provision of wheelchairs
3. Wheelchairs should be appropriate and affordable
4. Government should develop a policy on wheelchair standards.

DWSO believes that it is essential that DPOs are involved in wheelchair provision as they are well placed to carry out a number of roles including:

- Defining wheelchair user's needs and barriers to equal participation and opportunities
- Identifying people who need wheelchairs and linking them with wheelchair services
- Advocating that wheelchair services comply with agreed guidelines and advocating against inappropriate wheelchair provision
- Raising awareness of the need for effective wheelchair service provision and financing
- Consulting with policy planners and implementers in the development stage of initiating wheelchair services
- Supporting wheelchair users in the community by providing peer support and training.

Services:

Institutional-governmental services: China Service for Development & Supply of Devices for Disabled

Chen Guang

China Service for Development & Supply of Devices for Disabled, China Disabled People's Federation, Beijing, China

Introduction

There are 60 million disabled people in China; the overall rate of assistive apparatus supplied reaches 10 percent in urban area and about 2 percent in rural area.

Since 1985, the China Government included in the national plan the undertaking for providing assistive apparatus and services for disabled people. The Government has already implemented four Five-year National Plans, this year it began to implement the fifth Five-year National Plan.

During the last Five-year National Plan, five million one thousand and seventy six hundred (5,107,600) pieces of assistive apparatus were supplied, among them 300,000 pieces free of charge and 70,000 standard artificial limbs for poor disabled people free of charge or half free of charge. Some 180 artificial limbs assembly stations have been established.

The China Disabled People's Federation is the organization delegated for disabled people; it takes on the function as "deputy for service and management"; it takes on some government commissioned administration functions; and develops and manages the undertakings of disabled people. At present, it has established provincial, city and county level disabled organizations nation-wide.

Different levels of disabled people's assistive apparatus supplying stations are controlled to some extent or other by disabled people's federation organizations; these are the principal parts for providing the supply service of assistive apparatus to disabled people, the main functions being consulting, supplying and service. China has now set up more than 1,000 provincial, city and county level disabled people's assistive apparatus stations, which form the basic national-wide supply and service system. The corresponding level of Government assures the costs for the office, salary for the staff and the daily expenses.

Wheelchair provision

There are now about 50 wheelchair manufacturers in China of different sizes. Among them there are about 10 manufacturers that exceed an annual production of 100,000 wheelchairs, about 10 manufacturers are below 10,000 in annual production capacity, and the others are middle-size manufacturers. Nowadays the total production quantity is between 1.2 million and 1.3 million wheelchairs, including 600,000-800,000 wheelchairs for export. The local manufacturers produce all the models of wheelchair except for the racing models and the high technology electrical help-for-standing and intelligent wheelchairs. In addition there are about 10 foreign invested manufacturers, mainly from Taiwan, Japan and USA.

The China Government has stipulated a favourable tax policy (tax-free or reduced tax) for the enterprises that are manufacturing or distributing wheelchairs and, in recent years, the Government has increased the subsidy for disabled people when buying an assistive apparatus and improved in quantity of the assistive apparatus provided free of charge for the poor disabled people.

The China Government attaches importance to donation of funds from organizations or individuals, no matter whether from overseas or domestic, in order to encourage charitable donations. The China Government is now stipulating a related rule of law and policy concerning charitable donations that will give favourable tax conditions for the donors. The China Disabled People's Federation positively has cooperation with the international organizations, such as Taiwan Chao's Foundation and the Wheelchair Foundation from USA,

which jointly donates the wheelchairs to the poverty-disabled people in Mainland China.

The channels of identifying the needs of disabled people include:

- Different disabled Federation organizations, which supply and service assistive apparatus, regard one of their tasks to closely collaborate with disabled people, to collect information, and identify their needs;
- Different assistive apparatus supplying stations specialize in consulting with disabled people regarding the apparatus and supply service. They keep in broad contact with disabled people, as they are the main channel of identifying their needs and situation;
- Other methods: establish a website, collect information by letter and telephone.

Supplying service to the users by the following means:

- Set up shops: put the assistive apparatus and photographs in the shops, staff in shop to supply a service;
- Open a special telephone line and set up a website, publicise the telephone number and website to the society at large, supply service information to the telephone and internet inquiries;
- At the moment, most of the provincial assistive apparatus supply stations have a website for the service; including consulting and photographs of assistive apparatus content;
- Large scale chain stores have commercial websites which can supply related service to the users;
- Poor users, who need assistive apparatus, could obtain the subsidy from Government; the value of subsidy varies for different apparatus and regions, some are part-subsidy, and the others are full subsidy.

Finally I wish a successful conference, furthermore the China Disabled People's Federation could do more for our disabled people, and we have a great wish to exchange ideas and cooperate with the related organizations.

Services:
NGO with governmental purchasing: Motivation Romania Foundation

Cristian Ispas
Motivation Romania Foundation, Romania



Justification

- *High number of people in need of adequate mobility equipment*
 - most conservative estimates indicate a total need of 5,000 new wheelchairs per year in Romania (total population 22 million)
- *Lack of appropriate and affordable local products*
 - available products are orthopaedic style, supplied by private businesses (~1,400 pieces a year) or donated by international organizations (~1,200 pieces, new and second hand)
 - users can not afford to pay for the wheelchair they would like to have
- *Few training centres*
 - most physicians and therapists working in hospitals and state rehab centres do not assess the needs for appropriate wheelchair

High number of people in need of adequate mobility equipment

In Romania approximately 400 people sustain a spinal cord injury (SCI) each year, many of whom will be confined to a wheelchair. According to official statistics, in 2002 the number of people with motor deficiencies in Romania was approximately 181,000, or 22% of the total number of people with some form of disability (approximately 0.9% of the total population). Of these, we estimate that approximately 45% are wheelchair users or in need of a wheelchair. As accurate statistics in the other countries in the region are rarely available, we have used this figure to estimate the approximate number of people in need of mobility equipment¹. Overall, we estimate that there are more than 200,000 wheelchair users living in these seven countries with a total population of 53 millions.

¹ 0.9% of the total population of 53 million, of which we estimate approximately 45% to be wheelchair users.

Furthermore, the incidence of cerebral palsy in the developing world is 1 in 400 and many children and adults affected by this disease are dependent upon a wheelchair not just for mobility but in most cases for adequate seating and positioning. From our experience, special seating equipment can bring significant changes in the physical, mental, and moral development of children with CP and therefore their provision is an essential first step for including children with disabilities in the mainstream life of families, communities, and societies.

Unfortunately, the local production and provision (along with the training and assessment that is necessary) of such special seating and mobility equipment is generally non-existent in the region. In the past two years Motivation Romania Foundation (MRF) has produced and distributed more than 150 special seating equipments and is constantly faced with increasing demands from families, foreign and local NGOs, and institutions. This situation makes us believe that the number of children with cerebral palsy in the region who immediately need a wheelchair is over 2,000.

Lack of appropriate and affordable local products

In spite of this overwhelming need, only a small percentage of people are able to obtain and/or afford an appropriate wheelchair and the necessary training needed to live independently and to develop their capacity to create positive change for themselves, their communities and societies. The number of indigenous solutions to this problem (involving wheelchair production and distribution, and assessment, training and repair centres) has been limited. MRF's small-scale wheelchair production workshop has done pioneer work in this regard in Romania and has also donated wheelchair in neighbouring countries (Moldova, Bulgaria, and Albania) but at its current scale is unable to meet demand.

Locally available wheelchairs (produced, imported or donated) are in most cases outdated, orthopaedic style equipment that often comes in one size and is passed on without adequate assessment or training for proper use. Moreover, due to the unsuitable physical environment it breaks down quickly while replacement parts and repair services are generally non-available. In both design and quality, these wheelchairs inhibit active use which drastically reduces the number of wheelchair users living an independent life or engaged in economic/social/cultural activities.

The MRF wheelchair production workshop (7 of its employees are wheelchair users themselves) has received Government accreditation in 2004, which has resulted in the payment of 20% of our production for 2004 by the Health Insurance Agency. However, the current demand for new wheelchairs, estimated at around 5,000 wheelchairs, exceeds our current capacity of production. Under these circumstances, the current project will enhance the production and training capacity of MRF, enabling us to produce and donate a number of wheelchairs that is closer to the real needs of our target group, while at the same time assisting through peer group training wheelchair users receiving MRF equipments as well as equipments from other sources.

Lack of local assessment, prescription, and training centres

In the developed world, wheelchair users have access to wheelchair assessment and prescription services through which they can choose the most appropriate and individually suitable wheelchair, can request assistance in setting it up, in learning how to use it, and repairing it. In developing countries these services are virtually non-existent and thus the great majority of wheelchair users are confined to isolation, to an inactive and passive living. In the absence of adequate know-how, this cycle is also accentuated by the use of inappropriate wheelchairs that can cause numerous secondary complications such as pressure sores, drop foot and spinal cord deformities. Therefore, an effective assessment and prescription service is essential to any wheelchair provision programme.

Economic constraints

Economic constraints are important at both national and individual levels. At the national level, each of the target country is within the medium human development category of the Human Development Index. Government support for people with disabilities, though slightly improving, is still generally insufficient and does not cover all relevant aspects of this issue. In Romania

for example, Government funding for mobility equipment was restricted until recently to two companies that either distribute imported (non-active, orthopaedic style) wheelchairs or produce inadequate equipment. Also, the legal framework for non-discrimination and equal opportunities (for employment, health care, etc.) for people with disabilities, though theoretically extant, is ignored and rarely, if ever, enforced.

At the individual level, MRF has observed - through years of intense work with wheelchair users -that the majority of its beneficiaries come from precarious economic (mostly rural) backgrounds. The poor social intervention system, coupled with limited individual resources and access to adequate equipment, training and rehabilitation services seriously limit the chances of recovery for wheelchair users and for active participation in the life of their societies. Without the know-how necessary for maximum independence and functionality, the general situation of dependence and continuous poverty perpetuates itself. Breaking the cycle needs to start with the provision of adequate and affordable mobility equipment that encourage active living and provide the means to self-sufficiency, increased self-esteem, employment and full social integration.

The situation described above is typical of the conditions in each of the target countries of this project. For various reasons (spinal cord injuries, war-related injuries or cerebral palsy), the number of people in need of mobility equipment is constantly high. With limited personal or government resources, the provision of an adequate wheelchair is in most cases an exception rather than the norm. Against this background, the life of wheelchair users is that of continuous dependence, immobility, and social and economic isolation.

User needs

- Active style wheelchair
- Special seating
- Appropriate equipment for rural areas
- Standard wheelchair for elderly
- Sports wheelchairs
- Training services
- Maintenance

Motivation Romania - Service provision

- Production of customized equipment
- Assessment, prescription, distribution, and training

Production

- In January 2006 our production capacity increased from 20 to 60 wheelchairs per month

Products

The personalized wheelchairs produced by Motivation are unique in the region in that they respect the principles of correct wheelchair positioning that are very important for developing independence, maintaining health and preventing postural deformities and pressure sores. Motivation produces active wheelchairs for children and adults, special seating equipments for children with cerebral palsy and special adaptations depending on the needs of each user. We are accredited as a sheltered workshop by the National Authority for People with Disabilities in Romania and have contracts with the Romanian National Health Insurance Company for medical equipments distribution.

- *Mistral Adult and Junior*



- *Special Seating*



- *Sport*



Assessment, prescription, distribution

- Through our network of trained physical therapists and technicians
- In Hospitals, Rehabilitation Centres, NGOs and Institutions



Peer group training

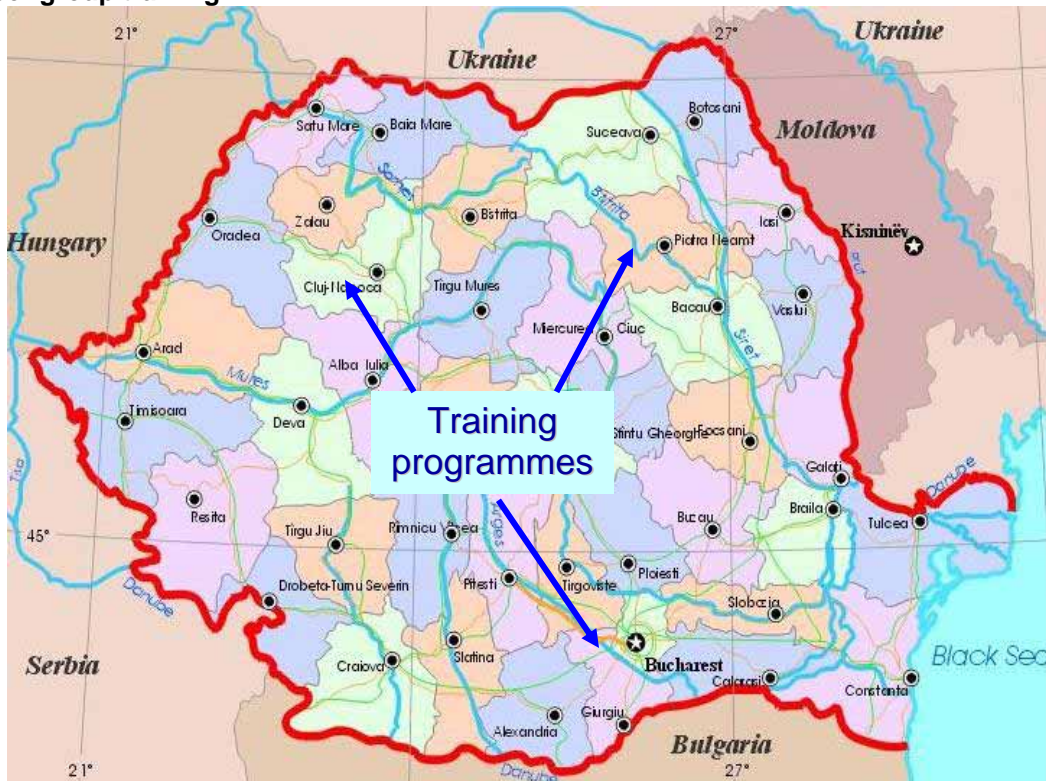

Our peer group training programme develops the abilities of users in the following areas:

- *Correct positioning and basic independent living skills:* The wheelchair is the first step towards independence, but it is not sufficient. MRF delivers its wheelchairs together with wheelchair skills training of mobility at home, on the street, at work or through sports. We provide counselling and training aimed at regaining self-confidence, personal independence and social integration. We also provide information about

workplace accessibility, adapted equipments (for bathrooms, kitchen and office) and vehicles.

- *Vocational training and employment:* employment of people with disabilities is an important step towards social integration, as it contributes to increased self-esteem and financial independence. MRF promotes employment by offering vocational training, counselling in workplace accessibility and adapted transportation, and facilitating contacts with employers. We also propose alternatives to employers who cannot employ the legal quota of people with disabilities but wish to support employment at other organizations or institutions.
- *Sports and leisure:* including wheelchair basketball and tennis programs for junior and adults wheelchair users, and wheelchair accessible summer camp services at MRF's camp in Varatec, Neamt County (north-east Romania).

Available service alternatives

- Suppliers deliver imported wheelchairs; only one other local producer
- Training services are provided for a short period of time during post-traumatic rehab in hospitals
- Governmental services - medical approach of rehabilitation
- We work with partner NGOs to develop appropriate distribution and training services

Financing

- USAID funding for capacity building
- Governmental funding for wheelchairs
 - 2004
 - MRF - Certified producer and supplier of medical equipment
 - Contracts with County Offices of National Insurance Agency
 - Cash flow issues
 - Delays in reimbursement – up to 6 months
 - Payment schemes
 - Increased production
- Governmental and European Union training programmes for wheelchair users
- Private funding
 - Other governments and international organizations (DFID, Cooperating Netherlands Foundations, Save the Children, COMBER Ireland etc)
 - Businesses, individuals
- Sustainability
 - European Union funds after 1st January, 2007
 - Subcontracting services with local authorities

South-Eastern Europe

- Moldova, Bulgaria, Serbia, Bosnia & Herzegovina, Macedonia
 - Similar problems
- Former Yugoslavian countries
 - Landmine survivors



After 15 years of transition, countries in Eastern Europe remain difficult environments for wheelchair users. In countries such as Romania, Serbia and Montenegro, and Moldova where large percentages of the population live below the poverty line, people with mobility disabilities are among the poorest of the poor. Architectural accessibility and the availability of quality mobility equipment are limited. This environment results in many being confined to their homes, which in turn leads to restricted access to education, employment and consequently to income.

Since the fall of the communist regimes in the region non-governmental organisations (NGOs) involved with disability issues have been steadily growing. The promotion of these organisations is primarily due to the large flow of financial support from international donors such as USAID and DFID. However, as the economic and social situation in Eastern Europe stabilizes, international donors are re-shifting their focus and financial support to other regions.

In recent years most countries in the region have passed laws to facilitate the integration of people with disabilities. However, as a result of this shift in funding, there is a growing interest both from international donors and the disability NGO community that local and national governments should become more involved in funding the provision of decentralized, community-based support services for people with disabilities. Equally international donors expect NGOs to take the initiative in identifying alternative funding for their services to increase independence from international and governmental funds (which now represent a very small percentage of most eastern European NGO budgets).

Regional development

Wheelchair users in East Europe, particularly in countries such as the Republic of Moldova, Bulgaria, Serbia and Montenegro, Macedonia and Bosnia Herzegovina, still encounter great difficulties in obtaining mobility equipments that are suitable to their personal needs. Most mobility equipment available in these countries are second-hand, orthopaedic wheelchairs that are in short supply and are too costly for the limited incomes of people with disabilities. Most people with disabilities still live on state support, having limited employment opportunities.

Existing nongovernmental (NGO) support programs in these countries focus mostly on upholding the rights of people with disabilities in relation to their governments, and efforts are concentrating on raising awareness of the rights, abilities and accessibility needs of people with disabilities. In the meantime, little attention is given to:

- the need for affordable, active style wheelchairs
- the need to train wheelchair users how to be independent in their wheelchair, how to maintain their health
- employment or access funds to start a small business or make home accessibilities.

Disability organizations providing services for people with disabilities are often unable to provide the level of service needed due to the lack of sufficient financial resources, as well as due to lack of information regarding peer group programs, affordable wheelchairs, etc. As many international donors are retreating from the region, these organizations need to look at alternative means of funding their operations. However, progress is restricted by limits posed by domestic legislation, the development of the business sector, corporate social responsibility and level of income of the population in these countries.

In this context, Motivation Romania Foundation, with financial assistance from USAID Budapest and Motivation Charitable Trust, is working since 2006 in the following areas:

- Establishing in Moldova and Bosnia and Herzegovina of local Centres offering:
 - wheelchair assembly and maintenance
 - evaluation, prescription, distribution and training services
- Providing partners in the region with a replicable model of indigenous, sustainable training and rehabilitation centre for people with disabilities
- Setting up a regional network of specialists sharing know-how and information and cooperating in projects for the benefit of wheelchair users
- Creating the mechanisms for sustainability through policy advising and support in identifying sources of governmental and nongovernmental funding in each country.

For additional information please see:

- www.motivation.ro
- info@motivation.ro

Plenary discussion: Services

Chairman: Geoff Bardsley
Rapporteur: Anna Lindstrom

Information from Zimbabwe was clarified: life expectancy after a spinal injury is short due to pressure sores or urine infections which often occur together. HIV/AIDS also causes casualties due to a misperception that intercourse with a women with disabilities can cure HIV.

It was clarified that the Chinese programme of service delivery does include involvement of disabled people in the assessment done by manufacturers in major cities. Government has initiated local training programmes and assistive technology centres. CDPF also plans to create assistive technology centres locally where disabled people will be involved.

The use of the term prescription was discussed. Can the prescriber really know the life situation of the individual to make a proper prescription? The importance of prescription taking into account the full background information of the user was emphasised.

The opinion was expressed that an accident causing a disability does not necessarily mean an end to quality of life. The rehabilitation process and the individual's attitude afterwards are important to regaining quality of life. However there are differences between developing countries and developed countries. For example in Zimbabwe people do not survive for long after spinal injury.

The donor needs are also to be considered, but the users' needs must be the priority and find appropriate ways to recognize their contribution.

Products: Designs (including tricycles)

Tone Øderud, SINTEF Health Research, Oslo, Norway

Background

The World Health Organization (WHO) has estimated that 7-10% of the global population has a disability, and the resolution "Disability, including prevention, management and rehabilitation" (WHO 2005) states that 80% of people with disabilities, particularly in the children population, live in low-income countries and that poverty further limits access to basic health services, including rehabilitation services. The United Nations Statistical Office estimates there are 20 million people in the world who need a wheelchair, but do not have one. Recent studies have shown that more than 80% of individuals with disabilities in Namibia, Malawi and Zambia claiming that they need an assistive device actually have no device (Eide et al. 2003^b; Loeb and Eide 2004; Loeb 2006).

Approach and theory

The concept of disability during the past decades has developed from a medical model focusing on the individual's impairment to a social model of functioning and integration focusing on limitations in activities and social participation. The adoption of the World Health Organisation's International Classification of Functioning, Disability and Health (ICF) (WHO 2001) represents a milestone in the development of the disability concept, shifting from the medical model towards the social model. "The Standard Rules for Equalisation of Opportunities for People with Disabilities" (UN 1994) is also an important document with potentially strong impact on the future of people with disabilities.

According to ICF disability arises when an individual's ability to do daily activities, carry out social roles and participate in communal activities that are considered normal or common, is limited or hindered because of bodily, mental or intellectual reduced function.

Disability might also be described as the gap between the environmental demands and the person's individual functional capacity. A disability can be reduced by making the environment more accessible or improving the persons capabilities. Assistive devices can be described as any device (crutches, wheelchair, tricycle, walking frame, white cane etc) used in order to reduce the disability gap.

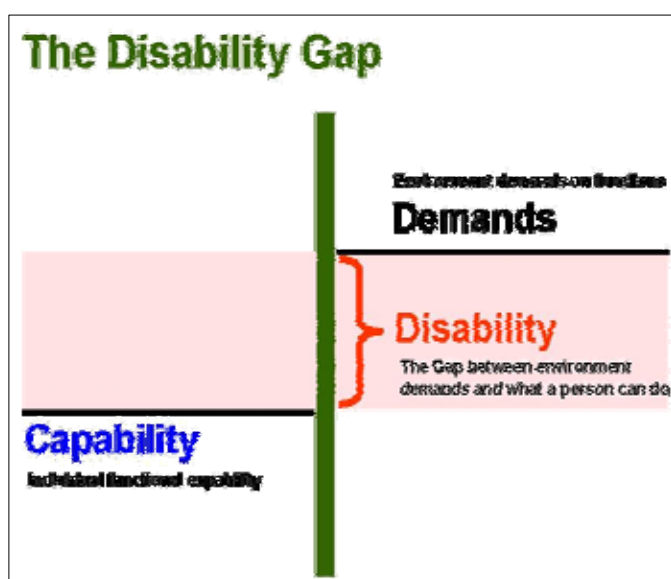

Figure: Disability gap

Poverty and disability seems to be linked together in a vicious circle (Yeo and Moore 2003), and there is a clear link between poverty and disability (Brundtland 1999). It is often noted that people with disabilities are poorer as a group, than the general population, and that people living in poverty are more likely than others to be disabled (Elwan, 1999); but there are many unanswered questions with regards to the mechanisms linking poverty and disability (Cornell et al. 1995).

A study on rehabilitation services in Uganda (May-Teerink 1999) reports that assistive technology improves mobility which is important to access education and employment. Supply of assistive technology might be regarded as one element in current strategies for poverty reduction.

Prevalence of disability

Bearing in mind important cultural and contextual differences and the perception of disability (Ingstad and Whyte 1995), the prevalence of poverty and the relationship between disability and poverty might not necessarily be the same in low-income countries as compared to the industrialised world. This also implies that the role of assistive technology and its impact on poverty reduction is not necessarily the same in industrialised countries and low-income countries. The dimension of culture, stigma and definition of disability are elements to be included when explaining and comparing the variation of prevalence of disability between different countries.

Kenya	1989	0.7
Malawi	1983	2.9
Namibia	1991	3.1
Zimbabwe	1997	1.9
Zambia	2000	2.7
Canada	1991	14.7
Sweden	1988	12.1
Norway	1995	17.8
UK	1991	12.2
USA	1994	15.0

Table: Prevalence of disability in selected countries
(<http://unstats.un.org/unsd/demographic/sconcerns/disability/disab2.asp> excluding Zimbabwe)

Statistics of user needs

Surveys of living condition among people with disabilities in Namibia, Malawi, Zambia and Zimbabwe have documented that households including persons with disabilities have lower living conditions than household without persons with disabilities. In average between 40-46% of people with disabilities have a physical disability. The major cause of disability documented in the study was physical illness or diseases, followed by congenital and accidents. Furthermore it was documented that around 50% of persons with disabilities acquire his/her disability before the age of 10 years.

The gap between the reported need for health services and the proportion of people having received the services they claim to need, documents that more than 80% of people with disabilities in Namibia, Zambia and Malawi have not received the assistive devices or services needed.

Type of disability	Namibia	Zimbabwe	Malawi	Zambia
Physical	40	46	43	42
Visual/hearing	28	32	39	44
Psychological	16	11	12	11
Communication	6	-	3	3
Others	10	11	3	-

Table: Type of disability (%)

Cause of disability	Namibia	Zimbabwe	Malawi	Zambia
Physical illness/disease	33	28	48	-
Congenital	27	19	17	30
Accident/injury	12	17	11	-
Witchcraft	3	10	4	-
Violence	6	6	1	-
Other	19	20	19	-

Table: Cause of disability (%)

Age of onset (years)	Namibia	Zimbabwe	Malawi	Zambia
From Birth	31	20	23	30
1-10	21	24	36	21,4 *
11-20	12	9	11	43,1**
21-60	32	32	23	-
61+	4	15	7	-

* Acquired disability between birth and age of 6,

**Acquired disability as children or young adults (less than or equal to 20 years)

Table: Age of onset of disability

Services	Namibia		Zimbabwe		Malawi		Zambia	
	Need	Recd	Need	Recd	Need	Recd	Need	Recd
Health services	91	23	94	92	83	61	77	80
Assistive devices	67	17	57	37	65	18	57	18
Vocational training	47	5	41	23	45	6	35	8
Traditional healers	33	47	49	90	58	60	32	63

Table: Type of services needed and received

Need: Percent of total number of disabled.

Received: Percent of those claiming they needed the services, actually receiving the services.

Results from the studies of living conditions among people with activity limitations:

- 40 – 46 % of persons with disabilities have a physical disability
- About 50% of persons with disabilities have acquired their disability by the age of 10
- Major cause of disabilities: Physical illness, congenital and accidents
- More than 80% of the people that need assistive devices or services have not received them.

User requirements

Wheelchairs should provide mobility and postural support for persons with mobility limitations. For many people with mobility limitations a wheelchair is a necessity for exercising human rights, improving quality of life and equal participation in the society. A wheelchair should also assist people with mobility limitations to carry out activities of daily living in their local community, and facilitate a healthy life. The wheelchair needs to be safe and it should not do any harm to the user.

For children, products for sitting and mobility are closely related to their ability to develop their skills and their mobility. Enabling a child to sit with good posture, using supportive seating, helps them to maintain health, e.g. aiding breathing and digestion, slowing down development of secondary disabilities and encouraging normal child development through giving access to learning.

Listed below are some of the key user requirements for a wheelchair:

- Facilitate the user in his/her daily activities
- Facilitate participation in society
- Individual adapted to fit the user, providing postural support
- Appropriate for the environment
- Strong

- Durable
- Nice design (reflecting the cultural aspect)
- Locally available
- Locally repairable
- Locally available spare parts
- Affordable



Figure: Wheelchair facilitating activities of daily living such as caring for family members (left) and mobility (right)



Figure: Wheelchairs facilitating school attendance (left) and participation in society (right)

It is of major importance that the wheelchairs are appropriate for the environment where the wheelchairs are going to be used also including the cultural dimension and the aspect of stigma. The wheelchairs also need to be appropriate for the materials and technology available in the local community.



Figure: Different local environmental and cultural settings

History of wheelchairs

The first traces of people using wheelchairs have been identified on Egyptian paintings going back to year 525 BC. From 1595 there are illustrations of King Philip II of Spain using his own wheelchair with four small wheels and a footrest. In 1783 John Dawson from Bath in England developed a three-wheeled wheelchair, with one small wheel in front and two larger rear wheels. From the 18th century the first wheelchair focusing on comfort is illustrated. It was a convertible wheelchair with reclining back and adjustable footrest. The model had 3 wheels, two large wheels in front and one smaller in the back.

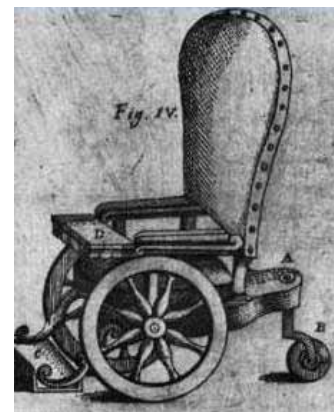
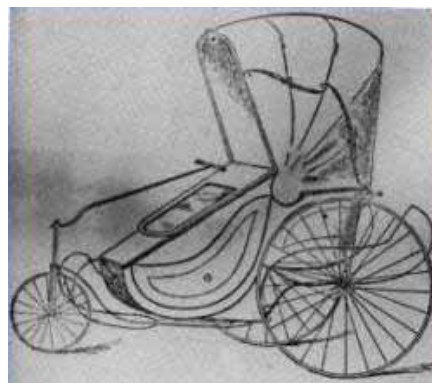

Figure: Wheelchairs from Spain 1595 (right), from Bath, UK 1783 (middle) and comfort wheelchair from 18th century



In 1932 engineer, Harry Jennings developed the first folding wheelchair made of steel. This was the earliest wheelchair similar to that used today. The wheelchair was built for his friend with paraplegia, Herbert Everest. Together they founded Everest & Jennings. Their wheelchair models are still being manufactured today.

Figure: Everest & Jennings wheelchair

Current wheelchair designs

Most wheelchair designs can be classified into three main categories; comfort wheelchairs, all-round wheelchairs and active/sporting wheelchairs.

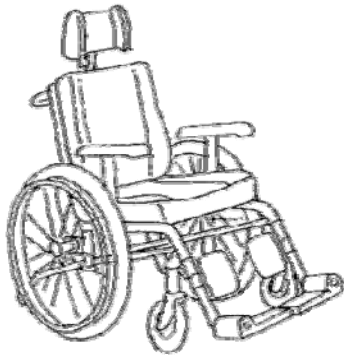

Comfort wheelchairs are made to be more comfortable for the user and allow for more resting. The sitting unit has possibilities for good postural support functions. Often the wheelchair is equipped with a headrest, the backrest or the seating unit can be tilted backwards and the footrest is adjustable. The wheelchair does not facilitate easy propelling, and the user is often manoeuvred by an assistant. People with severe disabilities and older people are the major user group.

All-round wheelchairs are the most frequently used model. They are designed to combine proper sitting position and good driving qualities. Usually the users propel themselves, but it is also provided with push-handles to allow for assistance. The all-round wheelchair usually facilitate for additional seating support and accessories. It is usually easily foldable with a cross-frame, but it could also be a fixed-frame with quick-release and sometimes foldable backrest.

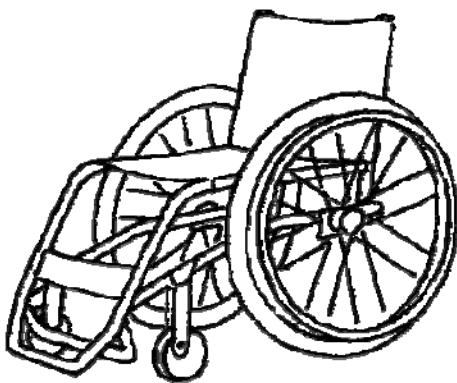
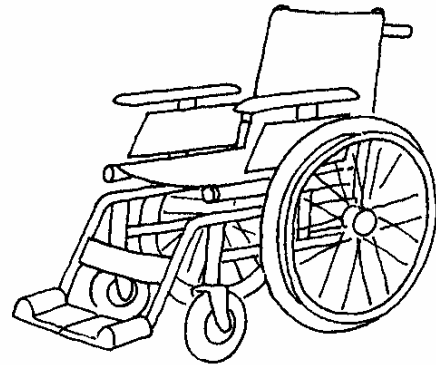

The active or sporting wheelchair is easy to manoeuvre by users themselves. It is used for sporting and other activities that require the user to move easily with a minimum of effort. It is low weighted and excellent for easy manoeuvring indoor and for paved environment. The chair is usually constructed with a rigid frame with fixed footrest, which makes it robust. Active wheelchairs are often used for people with paraplegia who have good hand function.

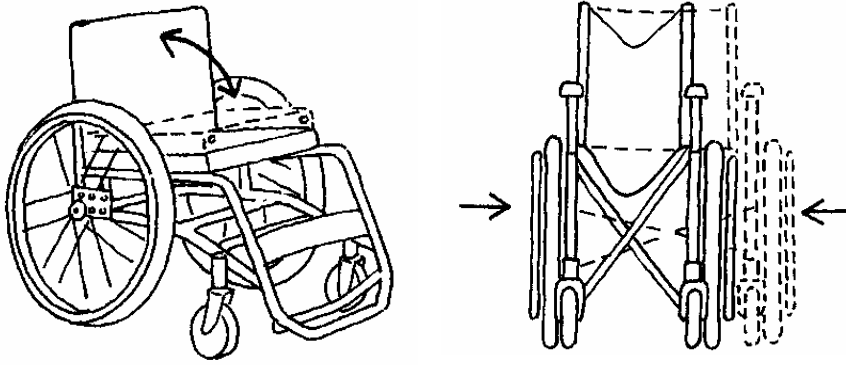

Figure: Folding frame wheelchair (left), and wheelchair with fixed frame and foldable backrest and quick-release for easy transport (right).

A wheelchair should provide the user with real mobility that will improve his or her opportunities to be an active integrated part of the local community and of the society in general, by being able to leave home or hospital in order to go to school, get a job, shop for food, and engage in activities that independently mobile people do every day.

In 1967 Huckstep developed the first wheelchair in Uganda made of local material adapted to the local environment. The wheelchair was a three-wheeler with a fixed frame made of steel, with two large bicycle wheels in front and a small wooden wheel in the back. The wheelchair has proved to be durable and it is still manufactured in Uganda today.



Figure: Huckstep wheelchair from Uganda

Since the early 1980s Ralf Hotchkiss and Whirlwind Wheelchair International, USA (formerly the Wheeled Mobility Centre) started their pioneering work developing foldable four-wheeled wheelchairs, designed for local environments and using locally available materials. Today the Whirlwind models are being manufactured in more than 25 countries around the world.



Figure: 4-wheeler foldable wheelchairs from Whirlwind, classic model (left), new Rough Rider model (right)

Motivation was initiated in 1991; they have designed a three-wheeled wheelchair made from locally available materials, easy adaptable and well suited to the rough environment of many developing countries.



Figure: Two different models of 3-wheeler rigid frame wheelchair from Motivation

Both the 3-wheeler from Motivation and the 4-wheeler RoughRider from Whirlwind are very well suited for moving about in the rough environment found in many developing countries, because of the long wheel base. The 4-wheeler are foldable and more easy to transport than the 3-wheeler. Both the models are strong and durable, and could be repaired locally with local materials and spare parts.



Figure: Motivation 3-wheeler wheelchair and Whirlwind 4-wheeler wheelchair



Wheelchair Foundation, USA started distributing donated wheelchairs in 2000. The wheelchair model is a 4-wheeler folding frame, being mass produced in China, and shipped to their destination for distribution. The wheelchair is suited for indoor use, hospitals and paved environment, not for rough environment. Many wheelchair users have experienced lack of repair facilities and lack of local availability of spare parts for donated wheelchairs.

Figure: 4-wheeler folding frame wheelchair from Wheelchair Foundation



Free Wheelchair Mission from USA is donating mass produced 4-wheeler wheelchairs with a rigid frame and seating made from a garden plastic chair. The seating is one size, and do not allow for individual fitting. The wheelchair is not provided in children sizes. Many wheelchair users have experienced a lack of availability of spare parts for local repairs.

Figure: Rigid frame wheelchair from Free Wheelchair Mission

Active/sporting wheelchairs are lightweight, and often with a rigid and robust frame. They allow for quick and easy manoeuvring on even ground.



Figure: Sporting wheelchairs being used for basketball in Zimbabwe and Zambia

In local environments, a traditional wheelchair might not necessarily be the appropriate device for providing mobility and activities of daily living. Sometimes local adaptations have to be made, suited for the person and for the local environment.



Figure: Local mobility device (Photo: WHO) (Werner)

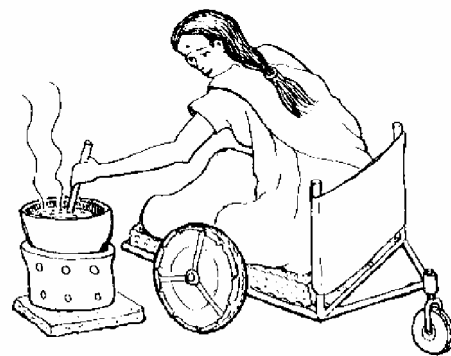

Figure: Local Mobility Device - Low Riders



Figure: Local adapted "3-wheeler" in Namibia

Children's wheelchairs

Stimulation and training are important for the physical, mental and social development of children. For children with activity limitations the wheelchairs need to provide both postural support and mobility. It is preferable that children with disabilities should be provided with appropriate mobility devices at the same age as non-disabled children develop their motor skills.

The wheelchair needs to be individually fitted to each child according to his/her needs. The width, height and length of the wheelchair should be adapted to fit the size of the child. If the wheelchair is not fitted correctly the children are at risk of developing postural problems (scoliosis, kyphosis, etc) and possibly digestive problems. Individual adapted postural support including a cushion is needed to prevent the increase of disability, prevent possible pressure sores and development of additional problems. In some situations a tricycle or a low rider may be a better solution than a traditional wheelchair.

Up until now the major focus on wheelchairs has been for adults, and it has found that there is a lack of appropriate wheelchairs for children in many developing countries (Andreassen et al. 2006). However, in the last few years there has been an increasing interest for mobility for children and the development in this area is slowly progressing.



Figure: Locally made wheelchairs for children from Kenya



Figure: Locally made 3-wheeler wheelchair for children from Tanzania

Imported wheelchairs for children might provide possibilities of individual fitting, but the wheelchairs often need to be carefully adapted to be appropriate for the local environment.



Figure: Imported wheelchairs for children

Unfortunately children are being provided with adults wheelchairs and inappropriate wheelchairs, because lack of information and lack of locally available wheelchairs for children. It is advised to put emphasis on developing children wheelchairs including special seating (Andreassen et al. 2006).

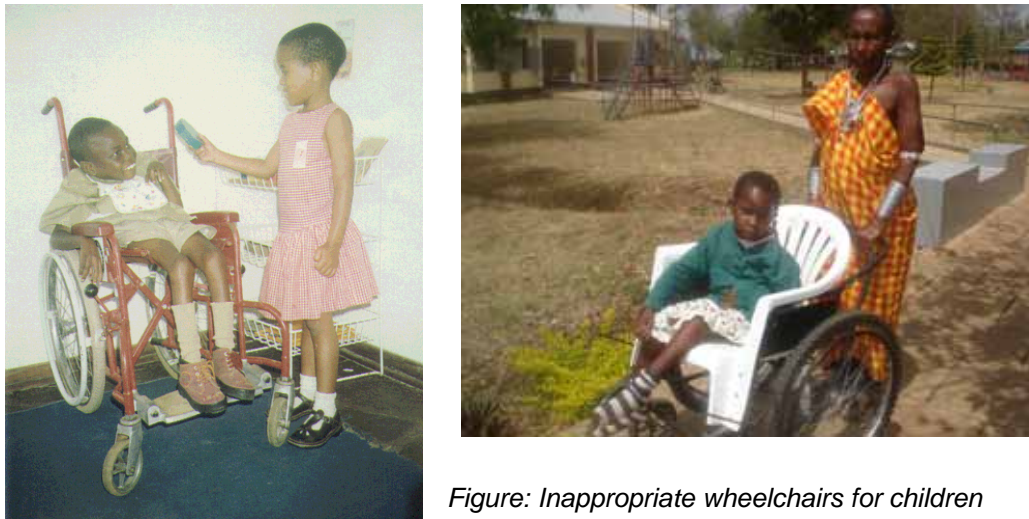

Figure: Inappropriate wheelchairs for children

Assembly concept

The concept of local assembly was developed in order to meeting the demand for provision of higher volumes of wheelchairs, and at the same time including local partners to be responsible for local assessment, individual fitting, repairs and services.

The assembly concept aims at combining the advantages of mass production of durable and adequate quality components at a relatively low price and the advantages of local assembly and provision of wheelchairs. Effective provision systems can be established in collaboration with local wheelchair manufacturers, Disabled People’s Organisations and local rehabilitation centres. The local partners have to be trained in assessment, individual fitting, seating, wheelchair manoeuvring, repairs and follow-up.



Figure: Wheelchairs for local assembly by WorldMade, Motivation and Alu Rehab AS

The wheelchair manufacturer Alu Rehab AS was one of the first companies to introduce the assembly concept. In early 2005 Motivation launched the Worldmade programmes to increase access for wheelchair users to both high quality wheelchairs and local wheelchair services. The Worldmade wheelchair components are mass produced in China at a low price and adequate quality and distributed in kit form for local assembly. The assessment, individual fitting, repairs and services are provided by local stakeholders trained in the process of assembly and provision of wheelchairs.

Tricycles

For providing mobility for longer distances for people with activity limitations, a hand propelled tricycle is often an appropriate mobility device. There exists a huge range of different designs of tricycles being made by local workshops or individuals. Often the owner of the tricycle has made it him/herself assisted by family and friends.



Figure: Local tricycles from APDK, Kenya and Uganda



Figure: Local tricycles from Uganda and Tanzania



Figure: Tricycles being designed and built from MADE Uganda and LOREWO, Zimbabwe



Figure: Tricycles from the Mobility Without Barriers Foundation from India and Ethiopia

Tricycle attachment

A hand propelled unit can be designed and attached to a wheelchair in order to convert the wheelchair into tricycle.



Figure: The concept of tricycle attachment (right).



Figure: Examples of tricycle attachments from Sri Lanka attached to a 3-wheeler in Tanzania and front adaptor attached to a traditional hospital wheelchair in Zimbabwe

Powered scooters

In many industrialized countries the powered scooters are popular and used by older people with activity limitations and people with disabilities.



Figure: Examples from older people using scooters (WHO 2000) (right)



Figure: Examples of scooters from India

Cushions and postural support

A wheelchair cushion is an important and integrated part of a proper wheelchair individually fitted to the user. The main functions of a wheelchair cushion are to distribute the pressure when sitting, prevent and reduce the risk of getting pressure sore, and provide postural support; the wheelchair and the cushion act together to form the seating system.

Wheelchair cushions might be successfully developed and manufactured locally by local partners and out of local materials if the personnel receive proper training in design, individual fitting and prescription of cushions. There is no ideal cushion, because there is a huge variation between the different user's individual needs, their tolerances of developing pressure sores and the local available wheelchairs. Other factors that also have to be considered when preventing pressure sores are the user's general health condition, diet and the shear forces present between the user's skin and cushion.



Figure: Cushion



Figure: Mould for making cushions

Service delivery process

Designing, developing and manufacturing of wheelchairs is only a part of the total service provision process, and sometimes this is experienced to be an easy part of the total process. The most challenging part is often to establish and sustain a service provision process ensuring that all persons in the need of a wheelchair will receive an appropriate wheelchair individually fitted to their needs in order for the person to do daily activities, carry out social roles, participate in communal activities and to exercise basic human rights.

The service provision process have to include activities of; information spreading and raising awareness, identification of users including screening and referral procedures, assessment of needs, identification of appropriate solutions including funding and procurement, product preparation and individual fitting, user training, follow up, service and maintenance and evaluation and feedback. The user is an integral part of service provision, and the user has to be in the centre of the service provision process.

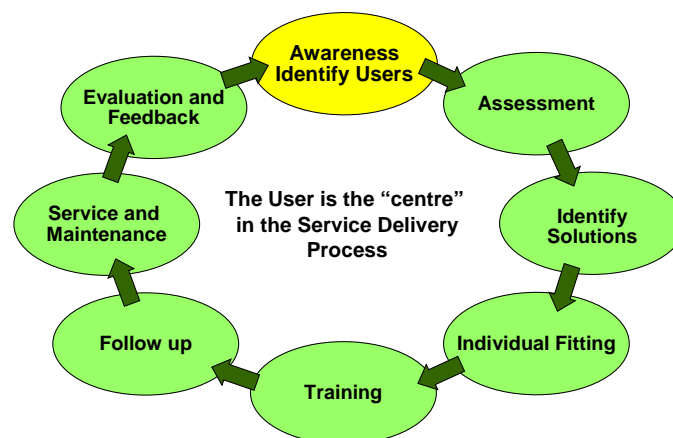

Figure: The main activities in the service delivery process

In order to implement and carry out the activities described in the service delivery process in the local communities, it is important to utilise the local resources available and to establish a fruitful collaboration between all the different partners involved in the process, including the user.

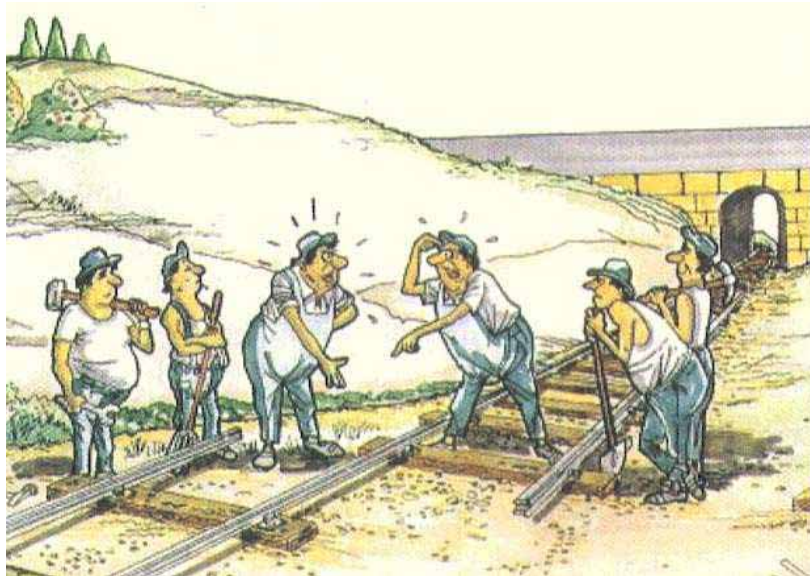

Figure: The importance of collaboration and team work

References and bibliography

Albert B. 2005. Lessons from the disability knowledge and research (KaR) programme.

www.disabilitykar.net

Andreassen TA, , Skøien RM, Øderud T. 2006. Children with activity limitations in Southern Africa. Oslo, Norway

Brundtland GH. 1999. Interagency consultation on disability World Health Organisation: Geneva.

Cornell IE, Lagerwall T, Tiroler G. 1995. Poverty and disability: a position paper. SIDA, ICH and SHI. Stockholm: Hjälpemedelinstitutet.

Eide AH, Loeb M. 2005. Data and statistics on disability in developing countries. SINTEF Report No STF78 A054506. Oslo: SINTEF Health Research.

Eide, AH, Nhwatiwa S, Muderedzi J, Loeb ME. 2003^a Living conditions among people with activity limitations in Zimbabwe. A representative regional survey. SINTEF Report No STF78A034512. Oslo: SINTEF Unimed.

Eide AH, van Rooy G, Loeb M. 2003^b. Living Conditions among people with disabilities in Namibia. A national, representative study. SINTEF Report No STF 78 A034503. Oslo: SINTEF Unimed.

Elwan A. 1999. Poverty and disability. A survey of the literature. Social Protection Discussion Paper Series No 9932. Washington DC: The World Bank.

Goffman E. 1963. Stigma: notes on the management of spoiled identity, Reprinted by Penguin Books 1990

Grut L, Ingstad B. 2006. Using qualitative methods in studying the link between disability and poverty, SINTEF Report No STF78 A054508. Oslo: SINTEF Health. ISBN 82-14-03797-2

Hem KG, Eide AH. 1998. Level of living among disabled 1987-1995. Samfunnsspeilet 2:20 – 25. (Norwegian language).

Ingstad B, Whyte SR. 1995. Disability and culture. Berkley: University of California Press

Ingstad B. 2003. Disability in the developing world. In: Handbook of disability studies. Sage Publications Ltd.

Loeb ME, Eide AH. 2006. Paradigms lost: is disability politically incorrect? Res Soc Sci Disabil 4: 115 – 134.

Loeb ME, Eide AH (Eds). 2004 Living conditions among people with activity limitations in Malawi. A national representative study. SINTEF Report No STF78 A044511. Oslo: SINTEF Health Research.

Loeb ME. 2006. Living conditions among people with activity limitations in Zambia. A national representative study. SINTEF Report. Oslo: SINTEF Health Research.

May-Teerink T. 1999. A survey of rehabilitative services and people coping with physical disabilities in Uganda, East Africa. Int J Rehabil Res 22:311 – 316.

Metts RL. 2000. Disability issues, trends and recommendations for the World Bank. SP Discussion Paper No. 0007. Washington: The World Bank.

United Nations. 1994. The standard rules on the equalization of opportunities for persons with disabilities. New York: United Nations.
www.un.org/esa/socdev/enable/dissre00.htm

United Nations Millennium Development Goals.
www.un.org/millenniumgoals

Werner D. 1988. Nothing about us without us. Palo Alto: Health Wrights,

Werner D. 1988. Disabled village children. Second Edition 1994. Palo Alto: The Hesperian Foundation.

WHO. 2005. Disability, including prevention, management and rehabilitation. Resolution adopted at the 58th World Health Assembly, Geneva.

WHO. 2001. International classification of functioning, disability and health. Geneva World Health Organisation.
www.who.int/topics/disabilities/en/

Wolfensohn JD, Bourguignon F. 2004 Development and poverty reduction. Looking back, looking ahead. Washington DC: The World Bank.

Yeo R, Moore K. 2003. Including disabled people in poverty reduction work: “Nothing about us, without us”. World Development 31:3:571 – 590.

Øderud T. 2000. Assistive technology for people with disabilities in Namibia and Zimbabwe. SINTEF Report No STF78 A900525. Oslo: SINTEF.

Øderud T, Grann O. 1999. Providing assistive devices and rehabilitation services in developing countries. The 5th European Conference for the Advancement of Assistive Technology, Düsseldorf, November 1999.

Motivation: www.motivation.org.uk/

Whirlwind Wheelchair International: www.whirlwindwheelchair.org/

United Nations: <http://unstats.un.org/unsd/demographic/sconcerns/disability/disab2.asp>

SAFOD: <http://safod.org/>

SINTEF: www.sintef.no/

Products: Specific designs: Motivation

**David Constantine
Motivation UK, Bristol, UK**

Introduction

Everyone is unique. So are disabled people and their way of life. Motivation recognises individuality and the importance of an appropriate mobility device that will assist disabled people to be active and do whatever they choose to do.

The design of a wheelchair, seat or limb is not a one-off process. Disabled people have vastly differing needs, so the equipment has to take into account such factors as the nature of the disability, the age of the person and the environment in which they live. As a result, many different designs of wheelchair, including three-wheel tricycles and supportive seating for children with cerebral palsy, have been developed.

To ensure that our work is sustainable and appropriate we train local people to produce and provide mobility products in two complementary ways: Firstly, we help set-up and strengthen local production workshops to produce and provide equipment for their communities. Secondly, we mass produce a range of appropriate and durable wheelchairs, called Worldmade, for developing countries which are assembled, prescribed and fitted by trained local services and workshops.

Disabled people are often the poorest members of society. This means that paying for equipment which will drastically improve their lives is completely unaffordable for most people. In many developing countries, governments do not prioritise or have the funds to provide wheelchairs or supportive seating. Motivation has set up mobility equipment financing funds for our local partner organisations so that they can subsidise the costs of production and provide wheelchairs for those in their communities who need them.

Wheelchair types

Four-wheel wheelchairs are generally more suited for active use in urban environments, rehabilitation centres or hospitals. They can have features such as folding backrests, folding frames or quick release wheels for ease of transportation by bus, train or car. However, many wheelchair sports are also played using modified four-wheel wheelchairs.

Motivation have designed and produced four-wheel wheelchairs for local production in Bangladesh, Poland, Romania, Albania, Nicaragua, Indonesia, Malaysia, and Sri Lanka. They are taught on the Wheelchair Technologists Training Course at TATCOT in Tanzania and the Worldmade Active Folding wheelchair is also a four-wheel design that is being trialled for use across the developing world.



Motivation's **three-wheel wheelchair** designs are most in demand because they are more suitable for rural and mountainous areas common to the majority of the population in many developing countries. These wheelchairs are more stable and manoeuvrable over rough terrain than a four-wheel wheelchair. Motivation also designs tricycle attachments for three-wheel wheelchairs to propel the wheelchair over long distances. Three-wheel wheelchairs have been designed and locally produced in Cambodia, Afghanistan, Sri Lanka and

Bangladesh. They are taught on the Wheelchair Technologists Training Course at TATCOT in Tanzania and the graduates produce three-wheel designs in nine countries in Africa. The new Worldmade Rough Terrain wheelchair is a three-wheel design that is being distributed by our partner organisations across Asia.



Every individual's body is different in size, weight, build, then add to this that every child with cerebral palsy is physically affected in many different ways. Then consider the rate at which children grow, the environment in which many disabled children live and that many are dependent to some extent on help in



everyday life from a carer, you may then start to understand the complex design that is essential to ensure that these children can to grow healthily, learn and play.

Motivation's design of **supportive seating** enables children with cerebral palsy to do just that: to be active, healthy and learn just as any other child. The first supportive seating wheelchair was designed in Russia in 1994 called the Moti. Following its success it was introduced in Lithuania as well and since then it has been further developed by both Motivation and by its local partners in Eastern Europe because of its appropriateness to that environment. In 1998 Motivation developed of a new Moti for the UK market; it is now called the Moti Activ and is being produced and sold by a British manufacturer.

Motivation has since then worked in Bangladesh in 1998 and Sri Lanka in 2000 to introduce supportive seating designs that are appropriate for each country. We trained staff to prescribe and fit the products for each child and to adjust the chair as the child grows. We are presently working in Sri Lanka to introduce a clip-on, clip-off design that will be distributed through a network of community clinics. This will enable Motivation reach out to the many impoverished families who cannot travel to centre-based services.

The primary function of a **tricycle**, whether it is attached to a wheelchair or is a stand alone product in itself, is for travelling longer distances more easily. This enables wheelchair users to be more independent and travel further from their homes, perhaps to work, to shop or to visit family. Tricycles are also extremely effective over rough terrain and in mountainous areas. Motivation tricycle attachments are designed to attach to three-wheel wheelchairs to give the user the long distance option as well as the basic wheelchair.



Motivation have designed and produced tricycles that attach to three-wheel wheelchairs in Cambodia, Afghanistan, Sri Lanka, Bangladesh and they are also taught on the Wheelchair Technologists Training Course at TATCOT in Tanzania and made by the graduates in nine African countries.



Worldmade takes our core values of providing individually fitted, high quality, appropriate wheelchairs and combines this with the advantage of economies of mass production to reduce costs and meet demand. All wheelchairs are prescribed, assembled and fitted by trained local technicians through our local partner service centres. Worldmade wheelchair:

Worldmade's aim is to distribute 10,000 wheelchairs a year. The Worldmade products provide a level of quality, durability and appropriateness far beyond what is currently available. Every wheelchair comes with a pressure relieving cushion to prevent life threatening health complications and give lasting benefit to each disabled person using the wheelchair.

Wheelchair services and training

An absolutely essential part of wheelchair provision is the assessment, prescription and fitting service. Our *Fit for Life* training courses have been strengthening the skills of local people to enable disabled people to be healthy and independent.

The Worldmade Rough Terrain wheelchair is the first product in the range that is being distributed to wheelchair users through our local partners in India, Papua New Guinea, Sri Lanka, South Africa, and Nepal. There are plans to work in Indonesia, East Timor and China and to work with the International Committee of the Red Cross to distribute Worldmade and deliver associated training. The Worldmade Active Folding wheelchair has been trialled by wheelchair users and will be ready for full scale production by the end of 2007.



Products:

Specific designs: The Whirlwind RoughRider™ and related design challenges

Ralf Hotchkiss
Whirlwind, USA



Introduction

What an opportunity for us all to be here and work together! While we come from a variety of approaches, we are among the few sharing an exceptional view. We believe that those of us with disabilities, regardless how poor we may be, have a right to the equipment we need for active mobility. All of us in this room are working together in a serious way to create mobility and integration throughout the world.

Who are we working for and how can we do it better?

Who are we working for? We are working for the people in the field. We are working for people who need to go to school, go to work, become mothers, fathers, and grandparents. We are striving to provide wheelchairs that are tough and easily maintained so that people aren't stranded when wheelchairs break down. We are all providing wheelchairs for life.

The characteristics and features of the RoughRider

- 4-wheel wheelchair
- Long wheelbase 56 cm (22 in), as compared to 40 cm (16 in) for most customary chairs.

Ralf: Fred is newly riding on a long wheelbase chair. Fred, can you tell us about it?

Fred: My first wheelchair was the classic Huckstep, with very large wheels at the front. Then I rode the Whirlwind Africa One, with a shorter wheelbase. Next I tried a Wheelchair Foundation Chair. Now I ride this longer wheelbase Whirlwind RoughRider. This one is the most stable because of the characteristics already mentioned. I don't worry about tipping, I just go. Also, transferring is easy, because I can use the footrest to transfer to the floor. Leaves stage by going down 16.5 cm (6.5 in) step, rolling smoothly on all four wheels.

Ralf: Much like 3-wheelers, the RoughRider is very unlikely to tip forward. Tipping forward is very important because the tip causes the rider to fall out of the front of the chair. These forward falls are the leading cause of serious injuries to riders of customary wheelchairs. When I rode a short wheelbase chair, I used to average three or four tips forward per year. Riding the RoughRider for the past four years, I still have not tipped forward.

- Smaller turning circle than a customary wheelchair
- Folds sideways to a 30 cm (12 in) width

Ralf: Fatuma, you were one who insisted a long time ago was that we needed to build a folding wheelchair. Please tell us why.

Fatuma: When travelling in Uganda the first thing the van taxi drivers ask is whether you have a folding wheelchair. If yes, then okay, you can go. If no, you are simply told you cannot go, or you are told to pay twice – two seats, one for you and one for your wheelchair.

- Adjustable rear wheel position (5 adjustments)

Ralf: The ability to put the rear wheel in a more forward position takes weight off of the small front wheels of the RoughRider, and puts this weight on the large rear wheels. Because the large wheels roll much more efficiently than the small wheels, moving weight from the small wheels to the large wheels enables the RoughRider to roll much more easily. This easier rolling is especially valuable over rough ground.

Less weight on the front wheel also keeps the RoughRider from turning downhill on side slopes as strongly as do standard wheelchairs. To fight the power of this downhill turn, the rider must often drag their hand on one handrim while pushing only on the other handrim, wasting half or more of their pushing energy.

Moving the rear wheel forward also gives the rider the ability to push the wheelchair with considerably more power. With the wheel in the forward position, the rider can reach more of the wheel, and make a much longer push stroke on the handrim. But moving the rear wheel forward does not come without some risk...the further forward the rear wheel is, the more likely the wheelchair is to tip over backwards. To minimize this risk, each rider must start out with the axle further to the rear, and only move the axle forward as they gain experience in handling and balancing the chair. This process of finding the optimum axle position is possible only if the axle position or the seating position of the chair is adjustable from front to rear.

Seat tilt: Some rearward seat tilt keeps you from falling forward when you hit a bump. Seat tilt also benefits your posture by keeping your body centred and balanced above your hips. The RoughRider has a standard rearward seat and seatback angle of 12°; more than the seats of customary wheelchairs, less than the seats of customary automobiles. Adjustments to the seat angle can be made during or after manufacture.

Everything in wheelchair design is a compromise. Our approach is to meet the mobility needs of people in rough environments as thoroughly as possible. At first we work without regard to the cost. If we can build a wheelchair that feels appropriate, then we work backwards and strive to reduce the costs, making the wheelchairs as affordable as possible.

Zimbabwe wheels: When this caster wheel is rolling over hard, smooth surfaces it touches the ground only at the centre of the wheel. The wider the caster is, the more easily it rolls over soft ground, like sand or mud. Although it is very wide, the rubber is cut away on the sides making it relatively light. The long trail of the caster fork, the small diameter of the caster wheel, and the light weight of the caster wheel all work together to eliminate flutter at high wheelchair speeds. The Zimbabwe wheel, if made with good quality auto tire retread rubber, will last a very long time. We have run these wheels for as long as 8 years, and we have only seen a maximum of 3 mm wear.

Sling seat: Solid seats can be lethal. We learned this the hard way. Our first model of a folding wheelchair, in Nicaragua in 1980, had a plywood seat. We provided a high quality

foam cushion with the wheelchair, but as with any foam it lost some of its spring over time. After several months, two users developed pressure sores as they bottomed out on the plywood seat. One recovered; a year later, the other had died. If there had been a sling seat under the foam cushion, the canvas sling would have stretched where the pressure was highest, and this would have reduced the pressure - perhaps enough to save him.

The difference is in the details

While the RoughRider differs in obvious ways from customary wheelchairs, some of the most important assets of the RoughRider are not visible to the untrained eye. Each of these assets reduces the frequency of breakdowns, and each one can be applied to virtually every type of wheelchair.

For most wheelchairs, the failures needing repair, in order of frequency, are:



1. Tires
2. Bearings
3. Upholstery
4. Rear wheels (spokes and rims)
5. Footrests and frame

Tires

Pneumatic bicycle tires roll more easily than other types of large tires, but they do go flat, especially after rolling over thorns or glass. For some 50 years or more, sealing fluids have been used to seal small and medium size punctures in bicycle tires. Sealants are working well in the RoughRider tires, and we are looking for ways to fabricate a similar fluid in developing countries.

Bearings

We find that the load rating of a bearing is a good indicator of how soon it will fail. Most failures are not due to impact but rather due to the wear of dirt and corrosion. Most bicycle hubs are not appropriate for wheelchairs because their axles are too thin, and bend when only supported at one end. In most chairs, sealed bearings are used, supported by a 12 mm hardened (class 8.8/grade 5) bolt. Of the 3 commonly available bearings with a 12 mm bore, the smallest, 12 x 28 mm, are far too weak and fail quickly. The next size, 12 x 32 mm, is strong enough to last longer but still can fail after 1 - 2 years of operation in mud and dust. The largest common size, 12 x 37 mm, is nearly twice as strong as the smallest bearing and can be expected to last much longer than the 12 x 32 mm. The cost of all three bearing types in most markets is essentially the same, so when sealed bearings are chosen, we recommend the use of 12 X 37 mm bearings.

Bearing replacement is often postponed because new bearings are so expensive. In recent months of doing wheelchair repair in Nicaragua, more than 25 users could show at least one bearing loose or frozen, and in some cases so damaged that the shaft or bearing housing was well on the way to being destroyed. The cost of a complete sealed bearing unit, bought by a wheelchair rider in Central America or Africa, is at least US\$2, or US\$24 to replace all 12 of the sealed bearing units of the wheelchair.

Using bicycle bearings instead of sealed bearings can reduce the cost of rebuilding all the bearings of a wheelchair from the US\$24 price of sealed bearing units to a mere US\$0.24 for a small handful of steel balls. Sealed bearings must be replaced as a complete unit, even if only the balls are damaged. Because bicycle bearings can be disassembled, broken balls

can be removed and replaced without replacing the bearing races. If there has been some wear to the races of the bicycle bearings, these races can be adjusted until the bearing is no longer loose.

At Whirlwind we are currently moulding standard bicycle hubs, using common ¼ inch bicycle ball bearings, into our front caster wheels.

In India, Alimco and Worth Trust are manufacturing wheelchairs using bicycle bearings in the rear hubs. Both groups make an axle of an ingenious design that allows the use of a standard bicycle hub. This axle is made by turning hardenable steel on a lathe, then hardening and tempering the finished axle. This axle could also function well as a caster pivot and is an appropriate solution as long as replacement axles are made available to the consumer. The materials, machining or the hardening techniques are not available in much of Africa and Central America, so we have had difficulty in transferring this technology to these areas.

Whirlwind is developing a similar system using the axle and bearings that connect the two pedal arms of a bicycle (bottom bracket bearings and axle). These parts are available world wide at very low cost. While pedal arm axles weigh more than the Indian tapered axles, they are nearly twice as strong, giving a significant safety factor. As with the Indian axles, the Whirlwind axles use common ¼ inch bicycle ball bearings.

Spokes

The spoke flanges on the hubs of most wheelchairs are about 2 mm thick. A spoke flange this thin allows the bend in the spoke to straighten when the spoke is stretched, loosening the spoke. In this way thin spoke flanges lead to the rapid breakdown of entire rear wheels.

The Whirlwind RoughRider uses spoke flanges 4 mm thick, with countersunk spoke holes 2.5 mm (7/64 inch) in diameter to grip the spokes as tightly as possible. We recommend that the spoke flanges be a minimum of 3 mm thick to increase the strength and life of the wheels.

Final comment

We offer the RoughRider and the technology it contains to all of you to examine, to test, to use and hopefully to improve upon. We hope that this will be the beginning of many years of steady progress toward the common goal that we hold so dear.

Products: Specific designs: HI Philippines tricycle

Matt McCambridge
Handicap International, Makati, Philippines

Summary

Mobility is not itself an end, mobility is a means to another goal. The diverse goals of a varying population demand diverse products and services. To maximise the impact of funder and customer resources, Handicap International in the Philippines will offer tricycles among the products available through our service providers in Mindanao. The term “tricycle” covers a broad category, generally defined as wheeled mobility devices for people with physical impairments which prioritise outdoor performance over indoor manoeuvrability. Tricycles have the potential for economic empowerment, for fun, for shattering stereotypes about disability and mobility products. However, meeting this product category’s full potential demands an investment in a design process. We must leverage:

- *User knowledge:* Involve users in the design process
- *Prior art:* Build on the successes and failures of other inventors
- *Prototyping:* Prototypes and short-run production before mass production
- *Testing:* Critically evaluate prototypes to nip problems in the bud
- *Anticipated services:* Know how the product coexists with clinical services

The current state of our development efforts can be read below. For 2007 we plan to launch two products in which we seek to maximise the advantages of *outdoor performance* and *cargo capacity* through two rugged, attractive, low-cost, manually powered, chain-driven tricycles. Research towards other tricycle products is ongoing and we welcome the input of others with experience in this field via our open source design portal at <http://www.freedomtechnology.com/opensource/tricycles>

Introduction

Eight key tricycle considerations

1. *Income generation:* The cargo capacity of a tricycle may facilitate income generation, as the combination of tricycle and rider has load carrying capacity which exceeds the carrying capacity of an unaided able-bodied person.
2. *Large diverse user population:* We have not determined the size of the market but it may be larger than the manual wheelchair market. Potential users include many people traditionally using wheelchairs, as well as users of other mobility technologies such as prosthetics, orthotics and crutches. Clients may use a tricycle in place of, or in addition to, another device.
3. *Postural support:* The postural support needs of clients vary widely. Some need nothing more than a bicycle seat; others require contoured cushions and finely adjustable foot support to avoid deadly pressure sores. For this reason screening by clinically competent personnel is critical.
4. *Maintenance:* As with any product we must consider both the availability of spares (things expected to wear out like tires, bearings) and the repairability of damaged parts, both in terms of the tools and the skills required to repair them. Use of familiar materials such as mild steel and familiar technologies such as bicycle parts leverages the skills of the hundreds of millions of mechanics in the developing world towards keeping our clients on the road.
5. *Terrain:* A tricycle optimised for pavement may be useless on poor roads; a tricycle which invests in off-road capacity may sacrifice some useful feature for pavement. In our initial product offering we prioritise “bad road” performance (including reasonable dirt roads) over either smooth road performance or true off-road capability.
6. *Traffic safety:* Tricycles are often used in traffic. Handling, braking, visibility, and rider competence become critical features which help to prevent serious injury or death. Failure modes effects analysis (FMEA) in the design process is important.
7. *Appearance:* The appearance of the product, and the appearance of the rider in the product, has an overwhelming effect on whether the product will be accepted and the extent to which the product will be used.

8. *Economy*: Delivering maximum value is critical in light of scarce resources and overwhelming need

Design process

Open source design

More in-depth and ongoing design and development data can be monitored via <http://www.freedomtechnology.com/opensource/tricycles>

Design as investment

Design consumes resources that could be spent directly serving a client. However, in many situations a present investment in design will maximise the long-term impact of resources.

This is true in our case for the following reasons:

No domestic product: No mass-produced tricycle is currently available in the Philippines.

No obvious import: No single design which was clearly optimal was identified in an initial review of tricycles available in other countries.

Design assets exist within our network: A small, flexible production facility, local staff of skilled, creative craftsmen and designers who work at economical rates, a local network of clinicians and people with disabilities to facilitate testing, an international network of other organisations with whom to pool knowledge.

Dual path

HI-Philippines has adopted two parallel paths towards providing highly functional and desirable tricycle products. We will move quickly to market with two fairly conservative designs based on proven prior art. These are available for beta-testing by interested customers now and will be in full production in 2007. We will additionally continue to research and innovate to explore whether alternate designs better meet user needs, while benefiting from the long-term “real world” data of actual customers of the 2007 product.

Testing: mechanical integrity and user validation

Concepts need to be evaluated according to two categories of criteria, both aided by standards:

Mechanical integrity: Does our product do what it is designed to do without breaking? We plan to model our efforts on standards and testing methodology created for wheelchairs with reference to other relevant industries.

User validation: Assuming our product does what it’s meant to, is what it does useful? Focus groups and beta testing help identify this at the prototype stage but must be carefully structured to yield valid data. Whenever possible, we ask for direct comparison between two or more concrete options rather than ask for abstract scoring (Appendix 2).

Standards: We are extremely interested in any work which exists defining mechanical strength standards for tricycles, or which characterises forces typically experienced by the product so that we can develop our own mechanical testing protocol. Since structural failures of fast vehicles ridden in traffic are unacceptably hazardous, we cannot accept a warranty-based “trial and error” approach. For user trials we can achieve reasonable safety by overbuilding likely failure points and building structures which fail slowly and benignly (for example tubes which bend vs. tear from their welds)

Failure modes and effects analysis (FMEA)

A formal process of anticipating failures and possible negative consequences helps increase the safety of the product.

Overview of prior art

Introduction

A great variety of tricycles for mobility by people with physical impairments are in production and in use all over the world. Additionally, other products used for mobility and load carrying (by people of all abilities) may have features relevant to tricycle design (e.g., the umbrella on a typical ice cream cart protects the rider and the cargo against an environmental hazard while encouraging the approach of customers).

Tricycles in developing countries

Below are five examples of tricycle technology in developing countries, all but one from Southeast Asia. Comments following the photo represent my understanding of prototype behaviour and the comments of users.



Figure 1 Chain-drive tricycle built at DISACARE in Lusaka, Zambia (2004 prototype)

The chain-driven tricycle developed for DISACARE in Zambia and TATCOT in Tanzania (product pictured in Figure 1 is from Zambia). This product can be manufactured with extremely simple tools and jigs, using many “off the shelf” bicycle components to simplify manufacture and repair. Designed for heavy cargo on bad roads of moderate slope, it additionally features adjustable shoulder-to-crank distance and adjustable footrest height (two features critical for use by clients with spinal cord injury which also improve usability for clients with other disabilities). This prototype was created with input from staff from Motivation, Whirlwind Wheelchair International, DEKA R&D Corp, APDK-Mombassa, and DISACARE of Zambia.



Figure 2. Rowing-action trike built at Kien Tuong factory, Saigon, Vietnam. Photo 2003

A “lever-drive” tricycle manufactured in Saigon by Kien Tuong wheelchair factory is shown in Figure 2. Moving steering column in a “rowing” motion propels tricycle via rear wheel, using

a mechanism like a foot-treadle sewing machine or an old locomotive. Rear-wheel drive tends to improve uphill traction in loose soil (due to the weight on either rear wheel vs the front travelling uphill in most configurations). This drive mechanism has “dead spots” in the stroke at which very little wheel torque can be generated via the lever; during normal operation the momentum of the trike carries the wheel past these dead spots. If you have ever played with a foot-operated sewing machine you have probably experienced this phenomenon. When the drive wheel is stopped at one of these dead spots and impeded by soft earth, stones, gravity, etc the lever may not provide enough force to move the trike, and the trike must be moved by other means (for example by pushing directly on the tire or the spokes, or pushrim if any).

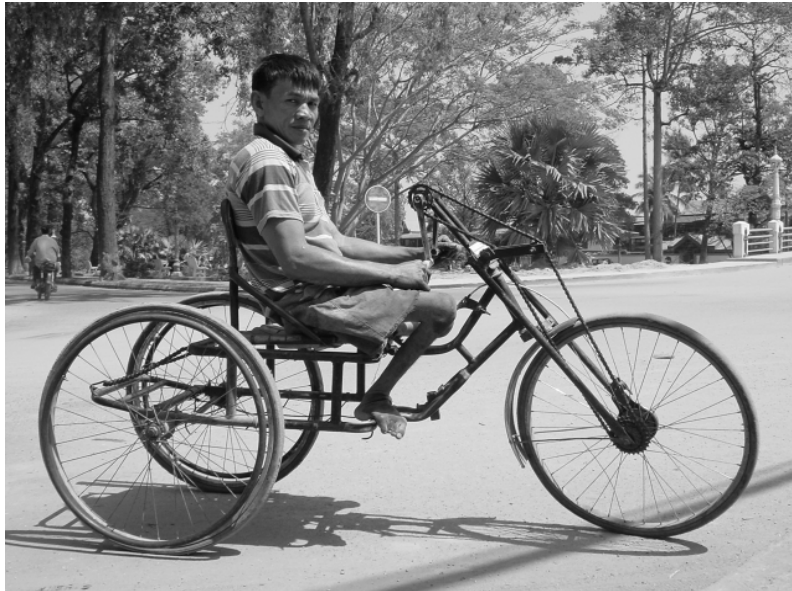

Figure 3. Chain-Drive tricycle with pushrims, Phnom Penh, Cambodia (courtesy HI-Belgium)

Note the very high ground clearance in the Cambodian tricycle in Figure 3, the cargo area behind the seat, and the pushrims on the rear wheels, a secondary rear-drive system



Figure 4. Roofed wide-wheelbase trike, local inventor, Philippines

In Figure 4 the tricycle’s weight and low centre of mass (lots of steel and rubber down low) and wide track width (34” track width, 36” wheelbase) give this trike great stability (it is

essentially unflippable on flat ground) although the weight makes for harder work. The rider sits close to the front wheel with hips abducted (knees spread) to provide clearance to turn the pedals which are relatively low (when ridden by 5' 7" rider, pedals interfered with knees when seated with legs forward). The inventor (Rolando Balacuit of Cagayan de Oro, Mindanao, Philippines) had childhood polio and now works as a freelance electrician, using this vehicle to commute through heavy traffic. The bodywork, which is painted yellow, provides both a covering and increased visibility to traffic during the frequent heavy rain.



Figure 5. Compact trike with bike parts, local inventor, Philippines

Figure 5 is included as an example of an extremely compact product which takes advantage of mass-produced components from bigger industries (a complete child's bicycle) to keep prices low. The rider/inventor (not the technician pictured above) had childhood polio and uses this device in addition to crutches to reach and navigate a crowded market. An extension of the original pedal allows lever-style propulsion, pushing only, by one hand (rider is dissatisfied with slow speed and plans to improve the drive system). The bicycle seat and footpegs are adequate for the rider although he reported soreness after long sitting. The narrow width (20" track width 23" overall width) allows access to tight spaces. Biggest advantage cited by rider: When not pedalling he appears to be sitting on a regular bike and does not feel that he "looks disabled".

Tricycles in wealthy countries

A good collection of commercially available hand-powered tricycles, also known as handcycles, can be found online at <http://rectech.ncpad.org/equipments/> (follow the "cycling" link).

Two examples of highly specialised machines made for different purposes:



Figure 6. Road racing trike for US Market (Courtesy Sunrise Medic)



Figure 7. Off road racing trike for US market (Courtesy One-Off Titanium Inc.)

Wheelchairs in developing countries

Much of the thought, technology development, and testing of wheelchairs contributed by the attendees to this conference is highly relevant for tricycle design. Many of the standards and guidelines in development at this conference should be valuable.

Other relevant products

- Foot-pedalled tricycles
- Bicycles
- Rickshaws and bicycle taxis
- Pushcarts (including vendor carts such as ice-cream carts)
- Battery driven scooters (used in wealthy countries for mid-range outdoor mobility)
- Three-wheel moped conversions

Summary of current understanding

User characteristics

The following is based on anecdotal evidence from professionals working with tricycles and similar mobility devices; we are actively soliciting more reliable data:

Market size: Volume unknown but appears similar in size to wheelchair market

Resources: Majority will have scarce financial resources for purchase or maintenance, similar to wheelchair market

Mobility devices used: Prostheses, orthoses, canes, crutches, walkers, wheelboards, low scooters, wheelchairs

Abilities and impairments: Diverse diagnoses: (Amputation, polio, spinal chord injury, cerebral palsy (Mild), traumatic brain injury, others). Some can walk (but not as far or as fast as they want to travel). Physical fitness; some upper body strength (at least one side) and cardiovascular fitness

User needs

Discussions with users, potential users, and designers yielded the following partial list of areas which concern users. Different users will prioritise these needs differently:

- **Performance**
 - Effort required to initiate movement from stopped
 - Effort required to maintain walking speed on typical terrain
 - Effort required to maintain running speed on typical terrain
 - Effort required to climb a typical slope
 - Maximum speed
 - Softest terrain which can be crossed
 - Maximum tolerable curb/obstacle
 - Maximum slope which can be climbed (before slipping or loss of strength)
 - Straight tracking while propelling
 - Negotiating tight corners
 - Turning space required, moving forward
 - Turning space required, with backing manoeuvre
 - Lateral stability in turn
 - Reversing
 - Braking, wet and dry

- **Propulsion**
 - Maximum performance with minimum pain, discomfort, effort
 - (through all propulsion modes: start up, cruising, obstacle negotiation, reversing)
 - Accommodation of impairment (trunk stability)
 - Full utilization of capability (for example both right and left arms, trunk muscles)
 - View of traffic and obstacles
 - Intuitiveness and predictability of steering
 - Intuitiveness and predictability of braking

- **Seating**
 - Pressure management (support for cushion)
 - Lateral stability (turns, rough road)
 - Forward stability (propulsion, rough road, collision)
 - Accommodation of typical clothing
 - Ability to do pressure-relief exercises (push-ups or leans)
 - Ability to nap or even sleep in device (e.g., for market days)

- **Transferring**
 - Safety, exertion, speed, convenience of transfer
 - From ground, wheelchair, standing
 - Stability of wheelchair during transfer

- **Rider protection: secondary disability**
 - Repetitive motion injury
 - Scoliosis
 - Generalised back/neck pain
 - Pressure sores

- **Rider protection: collisions, falls**
 - Visibility of device to traffic
 - Impact with ground (sideways fall)

- Impact with forward obstacle
- Impact with part of tricycle (e.g., hard edges, sharp corners)
- Traffic collision (front, side, rear)
- **Protection from environmental hazards**
 - These issues apply to rider and to protection of cargo (see Cargo capacity below)
 - Rider's hands, eyes, and clothing may have separate protection needs
 - Road: Mud, water, filth, nails
 - Nature: Sun, rain, wind
 - Tricycle: Chain grease, oil, sun-heated metal, sharp edges
 - Special (location dependent): Landmines, dangerous or irritating flora and fauna
- **Access to the environment**
 - Access to people (eye contact, handshake/hug reach and access)
 - Access to objects positioned for walkers (light switches, merchandise)
 - Access to ground (objects on ground, infants, growing plants, cooking fires)
- **Cargo capacity**
 - Secondary mobility device (wheel-board, crutches)
 - Bulk cargo (rice sacks)
 - Tiny cargo (cigarettes, candy)
 - Cargo tie-downs
 - Cargo protection, theft
 - Cargo protection, environmental hazards (see Protection from Environmental Hazards, above)
 - Cargo loading and unloading
 - Cargo access while in seat
 - "Vendable" cargo (cargo visible to customer)
- **Aesthetics**
 - Inherent beauty of device (form, materials, colour)
 - Positive associations with other products (cars, bicycles, athletic equipment)
 - Appearance of rider in the device
 - Attitude of rider (e.g., women sitting with knees far apart not always socially acceptable)
- **Impact on environment**
 - Soiling (tracking in mud or filth from tires, grease or oil from drive)
 - Damage (scraping doorframes, knocking over lamps)
 - Injury (what will it do to bystanders passing by, in a collision)
- **Portability and storage**
 - Manual carrying of device through impassable areas
 - Transporting via vehicle
 - Loss, theft of valuable parts (e.g. wheels, cargo)
- **Reliability**
 - Frequency of breakdowns
 - Severity of breakdowns (will rider be stranded?)
 - Predictability of approaching breakdown (e.g., rattles before falling off)
- **Costs of ownership**
 - Lifespan of consumables (e.g., tires)
 - Availability of consumables
 - Amount of required preventative maintenance
 - Ease of preventative maintenance (availability of skills and tools, cost)
 - Ease of repairs (availability of skills and tools, cost)
- **Cost to purchase**
 - Cost in proportion to quality of life improvement

- Cost in proportion to user or third-party budgets
- "As cheap as possible, but not cheaper"

Key product parameters

Product parameters are descriptions of different aspects of the technological solution that attempts to meet the user need. Product parameters affect whether user needs are met or unmet.

- **Drive mechanism**
 - Lever drives
 - Motor: gasoline or electric
 - Direct wheel drive: pushrim, hands on tires and spokes
 - Direct push on ground (foot, hand, cane)
 - Chain drives:
 - with freewheel or "fixed gear", single or multi-speed (derailleur, internal gear hub)
 - cranks in phase (R push L push) or opposed (R push L pull as in bicycle)
 - Front wheel vs Rear wheel
- **Seat/body support**
 - Footrest depth/level femur
 - Distance from shoulders to cranks
 - Back support
 - Shoulder interference
 - Seat depth
 - Hip abduction (spreading the knees)
- **Steering mechanism**
 - Steerable front single wheel
 - Steerable front 2
 - Torque steer: parallel vs perpendicular
 - Rake angle
- **Braking mechanism**
 - Parking brake (lockable brake used while transferring)
 - Stopping brake (brake used to stop while in motion)
 - Rim brake (side pull, centre pull, linear pull)
 - Hub brake (Coaster brake, band brake, disc brake)
 - Tire brake
- **Wheels**
 - Diameter, width, camber, pneumatic vs solid
 - Cantilevered axle vs supported at both ends
- **Chassis**
 - Two wheels in front vs one wheel in front
 - Track width, overall width, wheelbase length, overall length
 - CoG location relative to wheelbase and track width
 - CoG location relative to drive wheel and braked wheel
 - Material and finish
- **Cargo area**
 - Small object storage, large object storage
- **Rider protection accessories**
 - Environmental: roof, fenders, floor, pushrims, gloves
 - Traffic: lights, reflectors, paint, flags, horn

Manufacturing and distribution capabilities and constraints

Summary: Our tricycle will be centrally produced in the Philippines in a city with excellent light manufacturing resources, delivered within the country as loose cargo via ground and sea transport, and distributed by trained staff whose minimum skill level we can dictate. Initial volume for 2007 will be 20 units per month, scalable to whatever demand we identify.

Manufacturing: The Philippines has a wide range of industrial capacity producing products both simpler and more sophisticated than our tricycle, from backyard fabrication of motorcycle sidecars to high-volume production of motorcycle frames, steel furniture for export, shipbuilding and navigational aids. Sophisticated fabrication technologies such as high-precision metal forming, TIG welding of alloy aluminium and CNC machining are available. Most importantly for us, slightly lower tech manufacturing equipment and skills (manual lathes and mills, sand and die casting, tube bending, ordinary-tolerance steel stamping and forming, MIG welding) are ubiquitous and economical.

Our manufacturing strategy has been to focus in-house resources on processes central to quality and workflow, and outsource the rest to multiple vendors who compete for price and quality. Specifically, we focus on final frame welding (MIG), powder coating, assembly and quality control while outsourcing production of most components.

To be outsourced a component should meet the following criteria: The components can be stockpiled in advance, they can be readily checked for quality at time of delivery (vs. hidden defects which emerge only over time), and they are available from multiple vendors to avoid dependence on any single source. We currently outsource lathe-turned parts, casting, metal stamping, rubber moulding. As production volume demands, we can also outsource much of what is currently accomplished in-house (rough cutting, tube bending and metal forming, carpentry, upholstery, subassembly welding).

The large number of potential suppliers allows us to be very flexible with the volumes of outsourced components. The limiting factor for production volume with our current capital investment is the powder coating line, with an estimated maximum capacity of 400 tricycle units per month. However we plan for our initial year of production to produce no more than 20 units per month.

Physical distribution: We ship within the Philippines, via loose cargo on ferry or truck. As we are manufacturing in-country, delivery costs are relatively low and so "Flat Pack" design (a product which is designed to disassemble and fit into a very compact box for minimizing the cost of international container shipping) is not necessary (a secondary rather than a primary constraint).

Distribution services: Product will be designed to be distributed by trained personnel who have demonstrated a certain competency to safely screen clients, in harmony with the relevant parts of "Guidelines" to be developed at this conference. While many potential users of this product will not require rehabilitation services, to some clients it presents a hidden and serious risk: This product will be attractive to clients with compromised sensation, to whom any seated device presents a risk of pressure sores, and this risk may not be obvious to the client. The ability to identify customers who are at risk for pressure sores remains a critical responsibility of any distribution outlet. Many customers may benefit from a wide range of other services (physical and social rehabilitation, livelihood assistance and training, etc)

2007 design brief and working specifications

Product brief: the "Hercules" cargo utility tricycle

Summary: A durable, economical mobile platform for moving rider and cargo at walking pace on poor quality roads, capable of a wide range of tasks and adaptable to a wide range of mobility impairments

Target user: Adult or adolescent man or woman with mobility impairment desiring outdoor mobility. Lives along roads typically useable by bicycles, hand carts, automobiles. The user has potential to develop upper body strength (in at least one arm) and cardiovascular fitness;

has reasonable judgement regarding personal safety; interested in moving cargo, potentially as part of a livelihood activity that may involve interaction with customers and vendors; may spend 10 or more hours in device each day. Trunk control, grip strength, sensation, vision, and hearing are advantages but not absolute requirements to use the product.

Prioritization of needs (Figure 8):

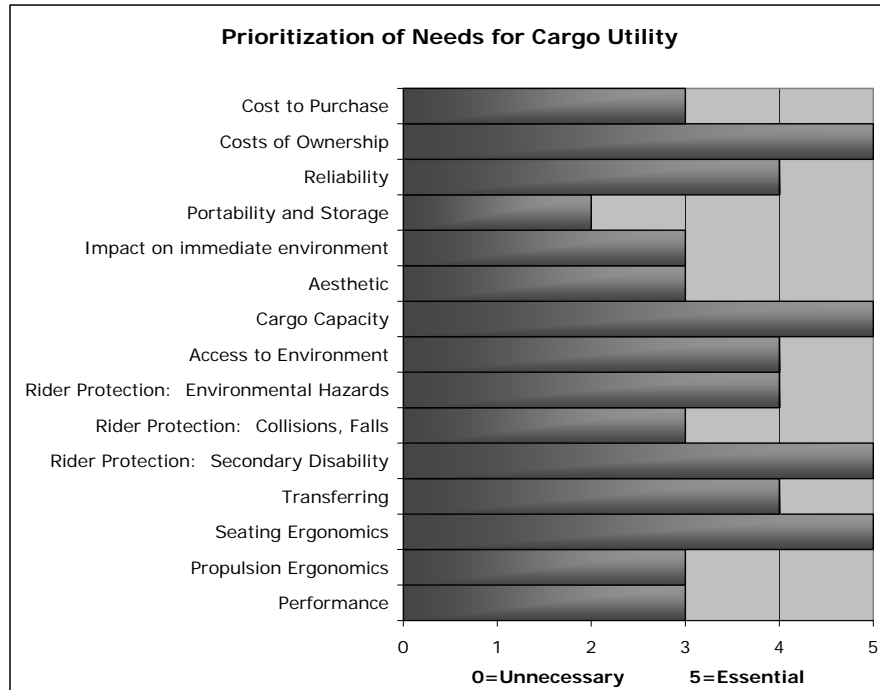

Figure 8. Prioritization of needs: cargo utility tricycle

Performance specifications for cargo utility tricycle:

- Performance: 50th percentile rider must be able to: maintain 2 m/s (4 miles per hour) on flat ground at an exertion level equivalent to walking pace, climb a 1:12 slope on wet pavement, dry pavement and dry packed dirt, cross 10 m of passable soft ground as defined below. Soft ground defined as the limit of what can be traversed without slipping by 1990 –2000 Suzuki Carry (Multi-Cab) rear wheel drive with no cargo and bald tires.
- Propulsion ergonomics: Range of motion of drive mechanism (lever or pedal) adjustable within range of arm motion with stationary trunk. Configurable for use by rider with arm strength and no trunk balance.
- Seating ergonomics: Standard chassis can be configured with multiple seating options for riders' diverse impairments and abilities. Optional adjustable footrest capable of providing foot support for pressure relief (level femur) to 5th and 95th percentile rider. Seat depth supports at least 80% of femur length for 5%-95% rider. Lateral support prevents lateral fall regardless of turning input at walking speed (swerve will not cause fall). Rider with no trunk control should be able to stay in seat during a head-on collision at walking speed (2 m/s)
- Transferring: Any rider who can transfer into a manual wheelchair with removable armrest from ground, seated, or standing should similarly be able to transfer to this device. Transfer to standing should be easy and safe compared to other products/seats.
- Rider protection:
 - Secondary disability: Configurable to provide support for pressure relief seating and pressure relief exercises, i.e., push-ups and leans (see Seating ergonomics) Propulsion system uses all available muscle groups to minimise strains (left and

- right extensor and flexor, and trunk muscle if available, should contribute to propulsion. Device operable by one handed rider at reduced performance level.
- Collisions, falls: Meets US bicycle and wheelchair standards for night visibility to traffic. At walking speed (2 m/s) on flat ground, no steering input should cause lateral fall. In frontal collision point of first impact for the rider should not break skin or bone.
 - Environmental hazards: Sun and rain protection equivalent to parasol. Mud and water flung from tire will not contact rider. Partial protection against splashed standing water.
- Access to environment: Seated eye level is within 0.5 m of standing eye level. Rider should be able to reach an object on at least one side of the tricycle from ground to standing eye level (within the limits of their trunk stability).
 - Cargo capacity: Configurable to hold various cargo up to 70 kg, can be fitted with multiple carrying devices to meet riders specification (cigarette tray, rice sack holder, cooler)
 - Aesthetics: Should not look “local” or “improvised”, should be indistinguishable from imported Taiwanese or Japanese product. Structural decisions will be made with consideration for overall lines. Aesthetics should denote quality and sturdiness, similar to a good quality economy car.
 - Impact on immediate environment: Walking speed collision with pedestrian will not break pedestrian’s skin or bone.
 - Portability and storage: One able bodied helper can assist the rider to climb a 15 cm kerb. Acceptable overall dimensions to be determined
 - Reliability: Maintained lifespan and service interval of product equal to that of a single speed bicycle. Option available to meet needs of clients both with and without easy access to pumps and tire repair service. Appropriately adjusted chain should not fall off more than once in 800 km. Frame will not fail in fatigue under specified use. (Specified use defined as rider less than or equal to 100kg, cargo less than or equal to 70 kg, all movement under users own power i.e., excluding being towed by vehicles) Parts expected to wear (bearings and tires) available at small town hardware and bicycle shops. Repairable using bicycle mechanic skills and tools.
 - Costs of ownership: Equivalent to single speed bicycle.
 - Cost to purchase: No more than 150% a standard manual wheelchair (i.e., trike cost US\$200)

Manufacturing and distribution specifications: Produced at HI production centre with components outsourced to other manufactures in the Philippines; uses materials raw materials and components available for purchase in the Philippines; distributed as loose cargo by truck and ship with final assembly at destination. Trained personnel will assess client and assemble product.

Initial prototype:



Figure 9. Initial prototype: cargo utility trike

The “Flash” sport commuter tricycle

Summary: A sporty, attractive product for recreation and commuting, connoting fun and athleticism; capable of high-speed and long-distance travel carrying small cargo.

Target user: Adult or adolescent man or woman with mobility impairment desiring outdoor mobility or recreation. Lives along roads typically useable by bicycles, hand carts, automobiles; potential to develop upper body strength and cardiovascular fitness; good judgement regarding personal safety; interested in speed and distance. Use pattern may resemble bicycle, i.e., occasional rather than constant use throughout the day.

Prioritization of needs:

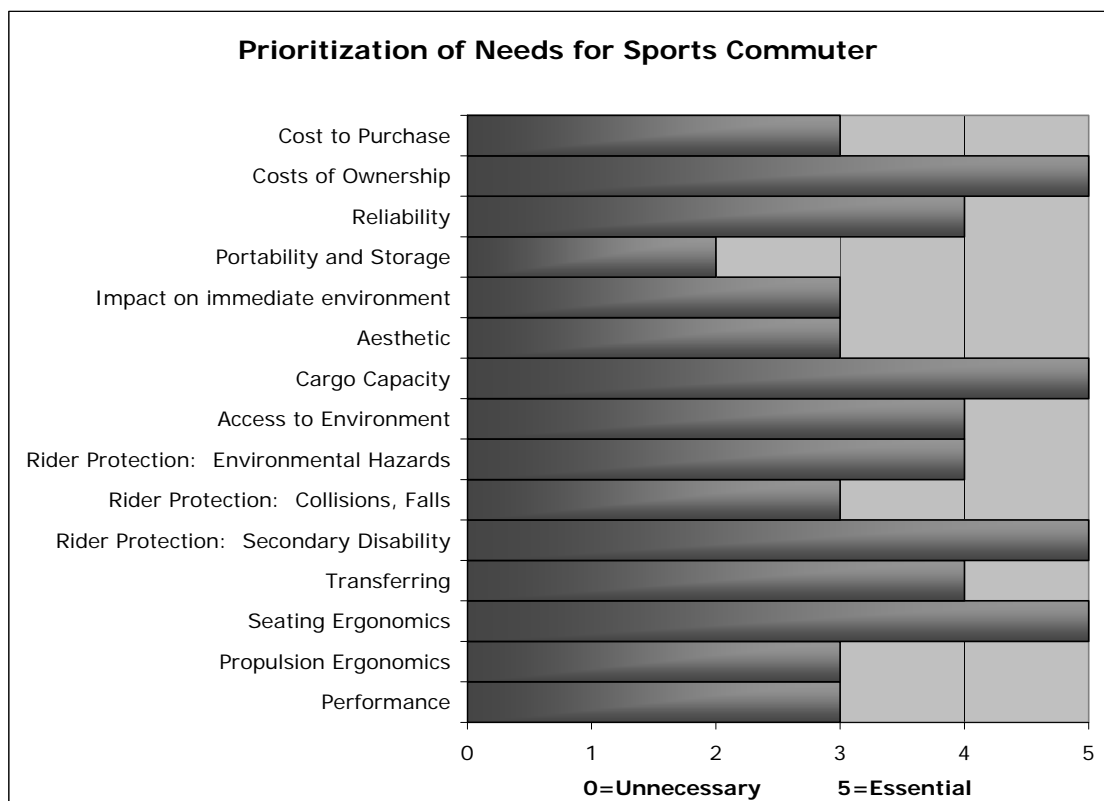

Figure 10. Prioritization of needs: sport commuter tricycle

Performance specifications for sport commuter tricycle:

- Performance: 50th percentile rider must be able to: maintain 2 m/s (4 miles per hour) on flat ground at an exertion level equivalent to walking pace, climb a 1:12 slope on wet pavement, dry pavement and dry packed dirt, cross 10 m of passable soft ground

as defined below. Soft ground defined as the limit of what can be traversed without slipping by 1990–2000 Suzuki Carry (Multi-Cab) rear wheel drive with no cargo and bald tires. User should be able to maintain sustained and peak “running” speed, greater than able-bodied person of similar fitness level.

- Propulsion ergonomics: Range of motion of drive mechanism (lever or pedal) adjustable within range of arm motion with stationary trunk. Configurable for use by rider with arm strength and no trunk balance.
- Seating ergonomics: Standard chassis can be configured with multiple seating options for riders’ diverse impairments and abilities. Lateral support prevents lateral fall regardless of turning input at walking speed (swerve will not cause fall). Rider with no trunk control should be able to stay in seat during a head on collision at jogging speed (4 m/s)
- Transferring: Should be possible but may be difficult or time consuming to any potential user of the device.
- Rider protection:
 - Secondary disability: Propulsion system uses all available muscle groups to minimise strains, left and right extensor and flexor, and trunk muscle if available, should contribute to propulsion.
 - Collisions, falls: Meets US bicycle and wheelchair standards for night visibility to traffic. At jogging speed (4 m/s) on flat ground, no steering input should cause lateral fall. In frontal collision point of first impact for the rider should not break skin or bone.
 - Environmental hazards: Most mud and water flung from tire will not contact rider.
- Access to environment: Rider should be able to reach an object on at least one side of the tricycle from ground to seated eye level (within the limits of their trunk stability).
- Cargo capacity: Should provide place to securely support ordinary backpack.
- Aesthetics: Should not look “local” or “improvised”, should be indistinguishable from imported Taiwanese or Japanese product. Structural decisions will be made with consideration for overall lines. Aesthetics should denote athleticism and speed, similar to racing bicycle.
- Impact on immediate environment: Walking speed collision with pedestrian will not break pedestrian’s skin or bone.
- Portability and storage: One able bodied helper can assist the rider to climb a six inch curb. Acceptable overall dimensions to be determined.
- Reliability: Maintained lifespan and service interval of product equal to that of a multi-speed bicycle. Option available to meet needs of clients both with and without easy access to pumps and tire repair service. Frame will not fail in fatigue under specified use (specified use defined as rider less than or equal to 100 kg, cargo less than or equal to 10 kg, all movement under users own power, i.e., excluding being towed by vehicles). Parts expected to wear (bearings and tires) available at small town hardware and bicycle shops. Most parts repairable using bicycle mechanic skills and tools.
- Costs of ownership: Equivalent to multi-speed bicycle.
- Cost to purchase: No more than 150% a standard manual wheelchair (i.e., trike costs US\$200) with higher performance options available at increased price.

Manufacturing and distribution specifications: Produced at HI production centre with components outsourced to other manufactures in the Philippines; uses materials raw materials and components available for purchase in the Philippines; distributed as loose

cargo by truck and ship with final assembly at destination. Trained personnel will assess client and assemble product.

Initial prototype:

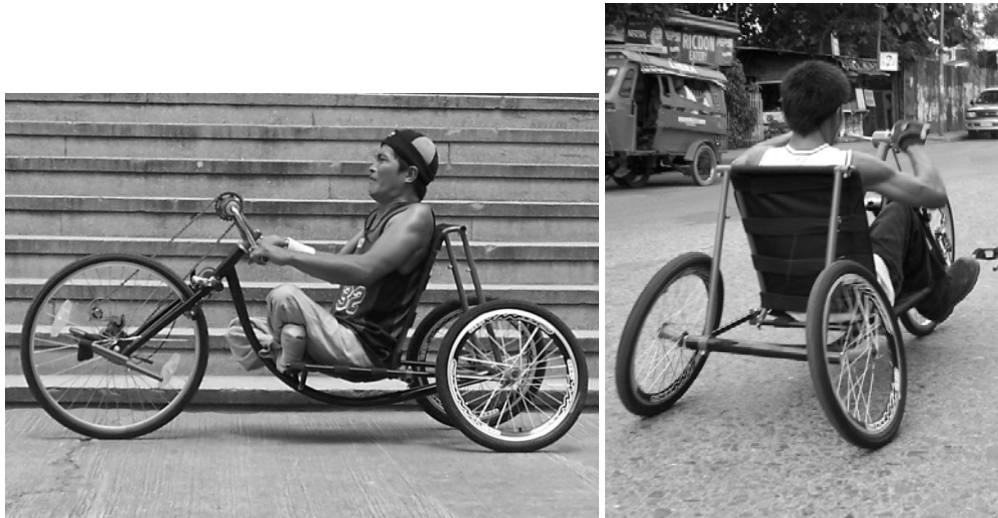

Figure 11. Initial prototype: sport commuter trike

Deferred products

The following products are still of interest to HI-Philippines and are the subject of ongoing research at a lower priority:

Alternatives to chain drive: More thoroughly evaluate and explore lever drives and other power transmission mechanisms.

Secondary drives: Ultra low-speed, high-torque drive for ramps and getting unstuck

Motorised trike: Similar to above categories but does not require arm strength or cardiovascular fitness. May use clean, quiet electric motor rechargeable at home for short-range travel, or small gasoline engine for longer range

Motorcycle/scooter conversion: a motor scooter rebuilt to allow use by people unable to balance a standard motorcycle or scooter.

Farmer trike: capable of slow walking speed over extremely rough and muddy terrain; may have features useful for agricultural work; may be an adaptation to a tractor or animal-drawn farm equipment rather than a stand-alone vehicle (note: it is tough to compete with a water buffalo on cost or capability)

Wheelchair trailer or pushcart: A device temporarily augmenting the cargo capacity of a manual wheelchair

Detachable wheelchair propulsion: Manual or motorised drive system which quickly attaches to ordinary wheelchair to give it tricycle performance capabilities

Further information

Further information on the above topics may be found at:
<http://www.freedomtechnology.com/opensource/tricycles>

Appendix 1: Handicap International in the Philippines

HI Introduction

Handicap International (HI) is an international humanitarian organisation based in Lyon, France that works for and in behalf of persons with disabilities (PWDs) and vulnerable groups in developing countries and in post-conflict zones. Handicap International is a recipient of the 1997 Nobel Peace Prize and currently works in around 55 countries worldwide.

Handicap International's French motto, *Vivre Debout*, which means "Live Standing Up", is the reflection of a philosophy of action based on the promotion and defence of human dignity. It is founded on the value of solidarity as expressed in the ideas of mutual aid, brotherhood, justice and impartiality. This value feeds the association's commitment to the equalization of opportunity.

For more on Handicap International's work worldwide, visit: www.handicap-international.org or www.handicap-international.org.uk.

Activities of Handicap International in the Philippines:

- Hilwaï Boat: Mobile rehabilitation services for remote islands
- Wheelchairs for Mindanao
- Rehabilitation
- Upgrading and updating of technology in orthotics and prosthetics
- Training of orthopaedic technicians
- Support to war victims and disabled people in Central Mindanao
- Orthopaedic and Prosthetic Workshop and Rehabilitation Centre in Cotabato City
- Training on community-based rehabilitation services
- Community approach to handicap in development (CAHD)
- Emergency assistance
- Expanding the network of organisations working with and for persons with disabilities

To learn more about these topics, visit the HI-Philippines website:

<http://www.handicapinternational.ph>

Wheelchairs for Mindanao

Handicap International (HI) is implementing the Wheelchairs for Mindanao project through a funding from the Leahy War Victims Fund administered by the United States Agency for International Development (USAID). The project aims to integrate disabled persons in their communities by improving their mobility and access to development opportunities, specifically by providing them with prescribed wheelchairs and other related services.

Wheelchair production centre

- A wheelchair production centre in Tagoloan, Misamis Oriental (near Cagayan de Oro City) was constructed in 2004 and now fully operational with the necessary tools and equipment for efficient production.
- Quality materials for wheelchair production are sourced locally to ensure affordability and easy access to spare parts (such as bicycle parts, etc.)
- The centre, which produces 60 wheelchairs in a month, is now developing its own brand of wheelchairs called Freedom Technology.
- Each wheelchair is made according to the needs of the patient to fit very well with his/her disability and environment. Each wheelchair is also fitted with a special cushion for pressure-sore prevention, a major consideration for clients who use their wheelchairs for long periods of time.

Wheelchair distribution and maintenance units

- HI has partnered with 5 local organisations that provide services to PWDs in Mindanao for wheelchair distribution.
- Called distribution units (DUs), they provide the services necessary when a person receives a wheelchair or other mobility device.
- The distribution units are strategically located in the cities of Cotabato (HI Phils.-Cotabato Field Office), Davao (Davao Jubilee Rehabilitation Foundation, Inc.),

Cagayan de Oro (Philippine Service of Mercy Foundation, Inc.), Zamboanga (Loving Witness of Hope Foundation, Inc.) and in San Francisco, Agusan del Sur (Loving Presence Foundation, Inc.).

Components and services

Technology:

- Emphasises making each unit a “globally competitive product” designed to empower its user
- 12 models are now available, ranging from standard daily-use wheelchairs to sports models, as well as tricycles available for beta-testing
- Social workers, physical therapists, and wheelchair technicians in a distribution unit work very closely with the client to make sure that the design of his/her wheelchair will be most appropriate to his/her condition to ensure the device’s maximum functionality.

Service and advocacy:

- Each DU provides training to the family for daily assistance and living environment adaptation of the wheelchair user, as well as community-based rehabilitation with families and communities.
- Facilitate social integration by raising or enhancing social awareness so that people may change their view about and behaviour towards PWDs
- Assistance in improving access to school for children wheelchair users, facilitate their enrolment in the schools, and also assist the adaptation of school buildings for wheelchair users
- Help facilitate PWDs’ access to livelihood/income-generating activities through training to enhance their entrepreneurial capacities
- Network of development organisations/associations for disabled persons strengthened to increase awareness and support for disabled persons.

Social enterprise:

- Emphasis on offering “extremely” affordable product without compromising quality
- Ensure economic viability of the production centre, sustaining its cost, its research and development and tooling and equipment to deliver the best craftsmanship as possible

When the project started in 2004, its initial focus was to provide mobility and rehabilitative needs to the injured victims of the conflict in Mindanao. Now in its third year, the project is expanding its service operations with a special focus on providing appropriate wheelchair technology to cater to the different types of physical disabilities of its target wheelchair users.

Appendix 2. Focus group evaluation form

Abbreviated for these proceedings where noted in italics

Overview:

The following exercises should be conducted with four devices, abbreviated as follows:

QUO: Status Quo: User's current mobility device, if any (wheelchair, crutch):

CRT: Pushcart: two-wheeled utility pushcart with handle, locally purchased

PT1: Prototype Tricycle 1

PT2: Prototype Tricycle 2

Attach photos of each to collected focus group results

Setup of Test Prototypes:

Abbreviated (verify proper adjustment of each prototype)

Test Group 1: Unloaded Mobility

Ask the user to cover the following marked distance at a comfortable pace. Time them and complete the following comparison and evaluation.

Flat Road

40 Meters, mix of cement or asphalt (bumps, cracks, sand, loose gravel) and firm earth (footprints do not indent)

QUO: Completed independently Completed with help Not Completed Did Not Attempt

CRT: Completed independently Completed with help Not Completed Did Not Attempt

PT1: Completed independently Completed with help Not Completed Did Not Attempt

PT2: Completed independently Completed with help Not Completed Did Not Attempt

Time to cover distance: **QUO** _____ **CRT** _____ **PT1** _____ **PT2** _____

Which product does the rider feel would be superior for this situation?

Best _____ 2nd _____ 3rd _____ Worst _____

Rider Comments:

Observer Comments

:

Soft Uneven Ground

40 M Soft ground, grass or mud (visible footprints 1 to 3 cm deep), stones and ditches up to 7cm

Abbreviated: Record results as per "Flat Road" above

Hill: Paved

Slope, Paved, 10 Meters, 12:1 slope

Abbreviated: Record results as per "Flat Road" above

Hill: Unpaved

Slope, Unpaved, 10 Meters, 12:1 slope

Abbreviated: Record results as per "Flat Road" above

Test Group 2: Cargo

User Selected Cargo

Of the following items, which would you most commonly need to transport? Please rank them from "most important" to "least important".

Abbreviated: List of common items including "Other _____"

Ask user to load the selected cargo, Move 40 M over mixed pavement, firm, and soft ground, then unload.

Abbreviated: Record results as per "Flat Road" above

Test Group 3: "Real World"

Urban

Urban obstacle course: Public market at Puerto, Cagayan de Oro from intersection to selected stores and back (approx 200 M, paved)

Abbreviated: Record results as per "Flat Road" above

Peri-Urban

Peri-urban obstacle course: From designated road to house via dirt path back to road (Approx 200 M mixed firm and soft ground, small slope)

Abbreviated: Record results as per "Flat Road" above

User-Designated

Additional terrain which user selects. Describe terrain, note user's stated reason for choice

Abbreviated: Record results as per "Flat Road" above

Test Group 4: Interview

Please rank the products in terms of which is most useful to you (*Abbreviated: Result scorecard*)

Please rank the products in terms of which has the best appearance (*Abbreviated: Results*)

What would you be willing to pay, per week, to use this product? (*Abbreviated: Results*)

The product is available for a 1-month free trial. Which if any would you try? (*Abbreviated.*)

What was the BEST feature or features of each device? (*space for answer*)

What was the WORST feature or features of each device? (*space for answer*)

Can you suggest ways to improve either tricycle? (*space for answer*)

Products: Specific designs: Wheelchair Foundation

Joel Hodge Wheelchair Foundation, USA

Wheelchair Foundation manufactures a wheelchair design based upon the *Everest and Jennings* “box style” folding frame.

Wheelchair Foundation wheelchairs have evolved several generations since our initial distribution models which featured fixed footrests, fixed armrests and limited wheel-set and castor options.

Wheelchair Foundation wheelchairs include the following features:

- Steel tubing with power coated paint in red colour
- High-denier nylon sling seating and back (with a cargo pocket and embroidery)
- Detachable, desk length, armrest
- Detachable, swing-away foot rests with height adjustable foot plates
- Composite wheels with solid polyurethane treaded tyres, or, spoked wheels with pneumatic mountain bike type tyres
- Sealed bearing throughout
- 2” x 8” front castor with either steel or composite fork assemblies
- Offered in five seat widths, 12”, 14”, 16”, 18”, 20”



Wheelchair orders are manufactured to the specifications of the in-country distribution partner after receipt of specific size requests. Wheelchairs are shipped boxed with adjustment tools, 280 per 40’ ocean freight container, plus spare parts (additional wheel sets, front castors, seating, bearing sets, misc. nuts, bolts and screws, etc.).

Wheelchair Foundation wheelchairs meet FDA and CE standards and are produced in ISO 9001 facilities

Products: Specific designs: Free Wheelchair Mission

**Michael Bayer & Don Schoendorfer
Free Wheelchair Mission, Orange County, USA**

Introduction

There are over 65 million disabled people in the world who live each day without the benefit of a wheelchair (WHO statement made at this conference). For families who live on less than \$2 a day, the cost of a wheelchair is beyond reach. These disabled adults and children are a tremendous stress on the family. Many either crawl or wait to be carried, or they spend their days in relative darkness. They are victims of polio, birth defects, viral infections, accidents, brutal mutilations, land mines, and warfare.

Years ago in Morocco, we witnessed a disabled woman crawl across a dirt road. She seemed not human; in fact, all human dignity was lost. This experience ultimately inspired us to make a personal commitment to make a difference.

The passion for this cause drove us to design a simple yet rugged and durable wheelchair with easily replaceable parts. The wheelchairs can be shipped and assembled anywhere in the world for less than \$45. When compared with the hundreds of dollars it costs to manufacture and ship a traditional wheelchair whose parts are not easily replaced, it is easy to understand what an innovative and life-changing gift this can be to a person unable to walk and who cannot afford to buy a traditional wheelchair.

And so began the foundation of Free Wheelchair Mission (FWM), a not-for-profit organisation based in Orange County, California whose mission is to provide the transforming gift of mobility to the physically disabled poor in developing countries. *FWM's overarching goal is to place 20 million disabled and impoverished people in wheelchairs.* The organisation has been diligently working towards this dynamic goal since 2001 by raising the funds necessary through donations from individuals to manufacture and ship the wheelchairs. In addition, FWM has recruited and is managing successful partnerships with like-minded humanitarian, faith-based, and indigenous organisations throughout the world who assemble and distribute these wheelchairs to those most in need. Our distribution partners include World Vision, World Relief, Operation Blessing, US Military, China Disabled Peoples federation, and Rotary.

The wheelchairs are manufactured in China and shipped in ocean containers that include 550 wheelchair kits, assembly tools, air pumps, cushions, patch kits, and harnesses for small children. It is the responsibility of the distribution partner to assemble the wheelchairs upon arrival, following picture instructions. It takes about 20 minutes to assemble each chair. This requires a strong commitment by the distribution partner to incur any expense related to the storing, assembling, and distributing of the wheelchair. FWM does not cover this cost for any distribution partner, as we have felt this demonstrated commitment is an important part of their role in this partnership.

Each distribution partner agrees to our requirements for selecting recipients of our wheelchairs. Our requirements include the following:

- a) The physical condition of the individual prevents him or her from walking at this time;
- b) The individual cannot afford to buy a wheelchair due to poverty;
- c) The individual is not in possession of a wheelchair;
- d) The individual is believed by the Distributor, and the family or personal friends of the individual interviewed by the Distributor's representatives, to be physically and mentally capable of using and benefiting from the wheelchair; and
- e) The individual has sufficient support from relatives or friends so that assistance is available to the individual with respect to his or her use of the wheelchair.

This agreement also requests that the following message be delivered to each beneficiary:
Dear Friend, the Free Wheelchair Mission staff believes that Jesus Christ has a special love

for the sick and crippled. We try to share the same concern now to the poor, especially those with physical immobility. Along with generous donors who fund this gift to you we pray for God's blessings on you and your family. God bless you!

Design criteria

Figure 1 shows a photograph of our wheelchair. We direct the reader to note our incorporation of common components such as bicycle wheels and a moulded resin chair.

The requirements we followed for this design include:

- requires minimal and simple repair
- relies on parts manufactured in high volume
- permit mass production and efficient shipping
- be suitable for use on unpaved terrain
- cost less than US \$50 to manufacture, ship, and deliver



Figure 1: The Free Wheelchair Mission wheelchair

Specifications of the wheelchair are as follows:

- 35 lb (16 kg)
- conventional 4-wheel design
 - 8" x 1" front castors
 - 24" x 1.95" mountain bike rear tires
- brakes on both rear wheels
- rigid, non-folding steel frame
- polypropylene resin chair (virgin resin) + UV stabilizer
- adjustable leg-length footrest
- a 3 cm thick urethane foam cushion with every wheelchair
- a hand air pump and patch kit fixed to the frame of every wheelchair
- a 5 strap adjustable harness for children and adults as needed
- nylon insert stay-tight nuts
- monthly double drum testing with 150 kg loads and 250,000 cycles

To date we have provided over 180,000 wheelchairs to over 60 countries.

Over one year ago we collaborated with Professor Susan Shore, Associate Professor, Department of Physical Therapy, Azusa Pacific University to enable her to conduct a follow-up study on the efficacy of our mission. She chose to have 200 wheelchair recipients interviewed, 100 in Peru and 100 in India. This was a randomized retrospective study. The inclusion criteria were that the recipient had no use of a wheelchair prior to getting ours and

that they had use of ours for at least 12 months. The survey questions were based don the International Classification of Function (ICF).

Activities surveyed focused on:

- physical mobility
- personal care and hygiene
- household chores
- personal and community interaction
- work and education

Recipients were asked to rate their responses as:

- no difficulty
- mild difficulty
- moderate difficulty
- severe difficulty
- unable to perform

Specific details on the results of this survey will be published at a later date. For this paper it must suffice to claim that our wheelchair provides resulted in:

- increases function
- improves general health
- heals pressure sores
- improves social life

Conclusion

We believe the preliminary findings of this follow-up investigation coupled with what we personally observe while distributing our wheelchairs and what is reported by our distribution partners is sufficient evidence to conclude that our wheelchair mission is effective in providing a useful degree of mobility to the physically disabled in developing countries.

Products:

Postural support including supportive seating

Shona McDonald
Shonaquip cc, South Africa

Shona McDonald: personal account

In 1982 our second child was born and diagnosed with severe spastic cerebral palsy with a 90db hearing loss. We were advised to put her in a home and have another child. There was a shortage of information and services for people with disabilities, and no appropriate equipment for children with cerebral palsy in South Africa. Information on equipment was difficult to find and most equipment had to be imported from UK, USA or Europe. Equipment could not be easily modified for the individual needs of each child.

With journals and brochures from overseas and with the help of a biomedical engineer from a university we started building our daughter the equipment she needed to provide her with mobility and the seating support to sit in the best and most functional position.

This enabled her to attend and take part in the local school and she was able to finish her schooling using an augmentative communication device (spelling device) set up on her wheelchair tray.

During this time I established a DPO for Alternative and Augmentative communication and became involved with many other parents of children with disabilities who had no access to appropriate equipment and started designing and manufacturing equipment for them under the name of *Shonaquip cc*.

The more we worked with communication the more frustrated we became with the seating and positioning of the children we worked with, as their poor seating made it impossible for them to access communication devices or communicate effectively.

It became clear that if we were not able to provide the correct equipment through the government health services 90% of the people in South Africa who needed it would never have access to it.

Approaching the local government rehabilitation centre to discuss problems, we identified the following scenario in wheelchair provision in the Western Cape Province.

Scenario pre-1995

- No dedicated government funding for devices
- General air of despair and apathy among therapists, doctors, parents, nursing staff, and carers
- Actual need not quantified or recognized by government or private sector
- Only basic wheelchair, walking aids and folding buggies (prams) available on tender
- Poor or no knowledge on science of seating and positioning
- Seating and wheelchair services not a dedicated service
- No devices or incorrect devices prescribed/handed out
- No seating services or follow-ups
- Only selected groups received some treatment/rehabilitation
- Severe deformities and pressure sores amongst wheelchair users
- Loss of function and increased hospitalisation of wheelchair users
- Access to the open labour market impossible without private funds
- Donations of equipment were received but the majority were inappropriate

Containers of second hand devices were regularly donated and distributed with no attention given to the appropriateness or the health implications for the user

Incorrect equipment was creating severe deformities that could not be corrected and immeasurable suffering. It was also impacting heavily on the Department of Health budgets and South African economy.



Children, although well cared for, were propped up on beanbags or with pillows, strapped into chairs or left lying on beds for years - this resulted in the development of irreversible secondary deformities and regular hospitalization for lung infections





Wheelchairs were often ordered in the biggest size in order to allow for future growth or to accommodate the largest possible user. There were no adequate children's wheelchair or postural support systems. Active users were given basic folding wheelchairs (usually without cushions), in order to attend school or to encourage social independence. The result was that these users were at high risk of developing spinal deformities and pressure ulcers.



Orthotic and prosthetic services were available but clinically most users still developed secondary complications. These included spinal deformities and pressure sores. Growing children developed deformities despite using devices which should have limited the development of these deformities. Schools and prosthetists designed wheelchair inserts where postural support was required. However, these devices were often not very practical, attractive or safe and neither did they allow for adequate postural support. Despite the devices used, normal postural alignment could not be achieved or maintained



The management plan

By working together, a group of concerned individuals from government services, suppliers, users and schools created a platform for discussion and problem solving. By involving officials from the provincial department of health offices, the group had an official channel of communication. The following groups were involved in the wheelchair and seating services discussions:

- *Service providers:* clinicians both private and government (therapists, doctors, orthopaedic sisters, community workers, rural clinic staff, and other interested parties)
- *Manufacturers:* local suppliers who could provide service and support and would respond to our suggestions for change of product design and quality
- *NGOs:* to lobby for policy to support our initiatives
- *DPOs:* to lobby for rights of the users
- *Schools:* to demand better services and equipment for the children they serve and to provide daily support and follow up at ground level for the users
- *Government representatives:* to empower the process with policy and legislation

To implement change as rapidly as possible we:

- Carried out a situation analysis (this was done provincially but we also investigated the situation in other provinces in order to give us insight into the national picture)
- Collected as much information as we could to support our demands and suggestions
- Outlined seating services as they existed and as we wanted to see them - Developed clinical protocols and procedures
- Designed, tested and manufactured appropriate equipment
- Provided training in seating and positioning at all levels (therapists, doctors, orthopaedic sisters, community workers, rural clinic staff, schools, NGOs ,parent groups, nursing staff, DPOs, carers, students and other interested parties)
- Established a database and waitlist system to be used by therapist who had attended the training we provided
- Negotiated funding both local and foreign
- Continued to support and fight for democratic change and policies that supported social development
- Linked with international partners to strengthen our capacity

The results

The results have been even better that we ever dreamed of:

- Provincial protocols and guidelines were developed. Eventually the National protocols and guidelines for assistive devices were based on the Western Cape's protocols and guidelines
- Wheelchair services with assessments, follow-up and maintenance components were established
- Key areas for development were targeted and empowered, e.g. schools, rural centres, etc.
- As the benefits of these services and distribution practices are recognized and understood, the Western Cape model of seating clinics and services are now taking place in a number of other provinces within South Africa
- There has been an enthusiastic response and commitment from both Government and private sector
- Our focus has been on high risk target groups, i.e., children and persons with newly acquired disabilities
- We have a wide range of strong, versatile and easily adapted seating and postural support products and equipment on our National Tender and available privately
- We have sourced committed and dedicated funding from Government and continue to motivate for improved budgets
- We have build excellent working relationships with private funders and negotiated and established appropriate management criteria
- We continue to source and disseminate appropriate knowledge and information to all stakeholders
- We are able to provide appropriate prescriptions and fitting services for wheelchair users in the Western Cape.



The situation has changed from a seemingly hopeless one, to one full of opportunity. We are now able to supply appropriate and supportive equipment to enhance seating and postural support. This aids in achieving a true 24-hour approach, thereby reducing the development of secondary complications while positively impacting on the client's quality of life.

Several other positive spin-offs were:

- A reduction of postural deformities
- A reduction of pressure sores
- Reduced cost in the management of secondary complications
- High risk groups being managed completely with assistive devices and NO therapy!





02/05/2004



13/08/2004



12/05/2005

The last two pictures above clearly show the effect of adequate postural support in maintenance of the spinal alignment and prevention of secondary complications. If left in the basic device in the first picture, this child would now have presented with secondary complications. This child is managed by devices alone and does not receive any therapy.



This young boy's postural needs have been safely and successfully supported over a period of more than four years, in standard equipment with regular adjustments to the back support and footrest height and the supply of a lap tray





In cases like this, where a child with cerebral palsy has been left in an unsupported position and has developed a scoliosis and gibbous we are now able to provide standard equipment with minor modifications to support his body and delay further deformities.

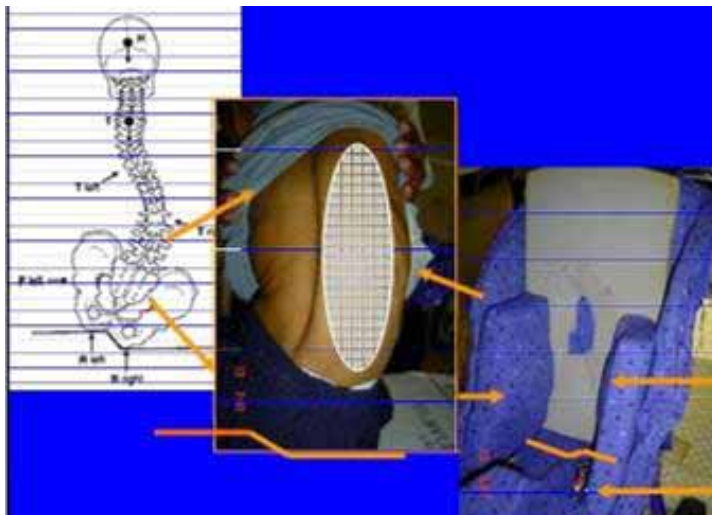

This picture shows the modifications made to support the scoliosis and accommodate the gibbous. Over the past four years his posture has stabilised and no further deterioration has taken place. This child also receives no therapy and posture is managed by devices alone.

Using simple positioning blocks we are able to reduce and inhibit unwanted movement patterns. Before we had access to commercially produced sidelyers as shown in the previous slides, positioners were made out of cardboard boxes and discarded/condemned hospital mattresses.



The same success is possible with adults. Once provided with the correct equipment, we are able to maintain a comfortable and sustainable postural alignment over a number of years without supplementing the management with therapy.



With the design of new backrest we have been able to remove inappropriate body moulds and replace them with modular systems that provide improved alignment and support in basic folding chairs. The enhanced function resulting from improved



biomechanical alignment of the body increased independency and functional ability in users. Clinically the rate of secondary complications was reduced and normal alignment and growth are facilitated in growing children.

These pictures show the X-rays of one child, comparing spinal alignment in the body brace on the left and spinal alignment in the local modular back on the right. It is clear that better spinal alignment is achieved in the modular back system. Planning to do formal studies on this back system is under way. Correct equipment and the resulting improved function and independence impact strongly on the social development and confidence of the user. Below, a young boy with T4 paraplegia is seen at home in a basic chair with the modular back.



Local and rural outreach clinics provide us with opportunity to identify client needs, and equipment gaps. This enables us to design and test new and more appropriate equipment on an ongoing basis.





Above the influence of appropriate equipment can be seen. A light weight self propelling wheelchair with modular back support allows for improved mobility and enhanced postural support for this young boy.



These slides show additional light weight self propelling devices for children at risk from as young as two years old. The wheelchair on the left offers modular back support and the device on the right is an upright wheeler, allowing for the combined benefits of standing and mobility.

Children are often expected to take part in school activities while sitting in inappropriate wheelchairs. This affects their ability to achieve their goals. As part of or outreach services we established school clinics. This has given us the opportunity to design more appropriate school equipment

In the past clients with high spinal lesions were put in high back reclining chairs. Despite the fact that the effect of gravity was reduced to some extent, the outcome remained poor. Often these patients present with poor alignment, pressure ulcers and scoliosis.





Old system front and side

New system front and side

We have now added a power base option to these chairs in order to get the client back out into the community and active again. This has made a very positive impact on their long term emotional and physical health.

We found that appropriate wheelchairs and devices clinically impacted positively on each individual user's quality of life;

- It changed perceptions of disability and brought the users out of their houses and into the community
- It increased the motivation of all stakeholders
- It reduced the cost of health care by effective prevention of secondary complications.
- It reduced the waitlist times

The current Western-Cape scenario



- We are refining guidelines and standards
- We support a long term vision and are all working towards the same goals
- We are in the process of developing standard outcome-based training packages





- We are replicating our model in other provinces
- We continue to build mutually beneficial partnerships with government and local groups
- We co-ordinate sustainable training and support services
- We believe that a wheelchair is a "body orthosis on wheels". (Bengt Engström)
- We recognize that it is our responsibility to make wheelchairs function to prevent long-term injuries.

Products: Pressure relief cushions

Jamie Noon
Noon Design, Santa Fe, USA

Introduction

An inadequate pressure relief cushion is the single part of a wheelchair that is most likely to cause serious injury or death. A pressure sore can start in 20 minutes.

The greatest challenges in promoting good cushion programmes in developing countries are lack of awareness and clinical skill. If people “distributing” wheelchairs knew or acknowledged the risks faced by the wheelchair riders they serve, they may place more focus on pressure sore prevention. The basic skills required are to be able to identify dangerous levels of pressure and to modify a cushion to reduce those pressures.

To say that every wheelchair must have a cushion is to say, at the same time, too much and too little. For someone with sensation, a cushion is merely for comfort and stability. They can live without it. For someone with no sensation at the sitting surface, they can easily die from using the wrong cushion (i.e., a flat sheet of foam).

When speaking of wheelchair cushions, the topics of product and service are inseparable. This paper will attempt to focus on the product side; however, some clinical service elements are necessary to complete the picture.

Performance factors

Factors which will affect the performance of a cushion include:

Weight: Cushions need to weigh as little as possible to aid transferring.

Coolness: Cushions should not cause excessive temperatures at the sitting surface.

Dryness: Cushions should not allow pooling or absorbing of liquid such as urine.

Stability: Stability of the user is important to maximize the functional potential.

Ease of use: Cushions should be simple to use and difficult to use improperly.

Comfort: If the user is uncomfortable when using the cushion they may stop using it.

Durable: Cushions should last up to 2 or 3 years before loss of performance.

Risk of catastrophic collapse: Sudden, total failure that puts the user at risk.

Pressure distribution

The pressures at the sitting surface (buttocks and thighs) are highest under the bony prominence of the ischial tuberosities (ITs) and the greater trochanters. These are the sites where pressure sores from sitting are most common.

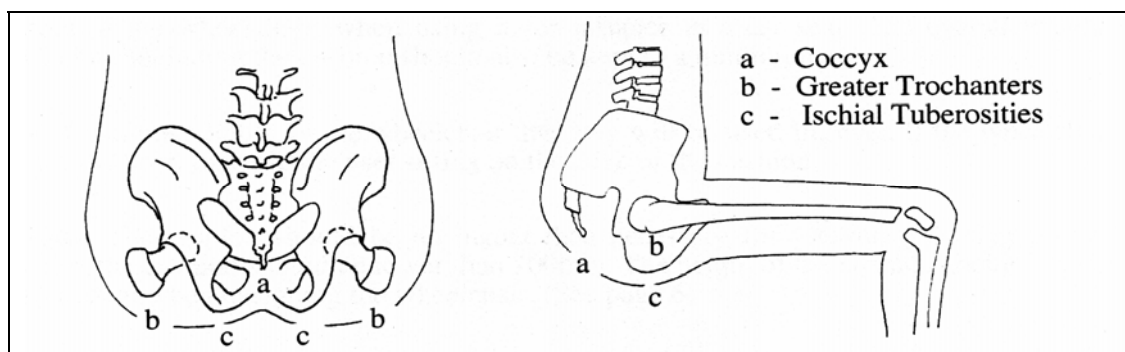

Figure 1. Sites at risk of developing sores

The amount of pressure at these sites varies, depending on the weight of the person, the shape of the bones, and the depth of the soft tissues under these bony areas.

- The areas at greatest risk are under the *ITs*
- The *greater trochanters* can support more weight than the *ITs* but are also at risk
- The *posterior thigh* is the area least at risk of pressure sores
- The *coccyx* is vulnerable, however, does not normally support weight when sitting
- Areas that have *previously had sores* will be at higher risk of developing a sore again.

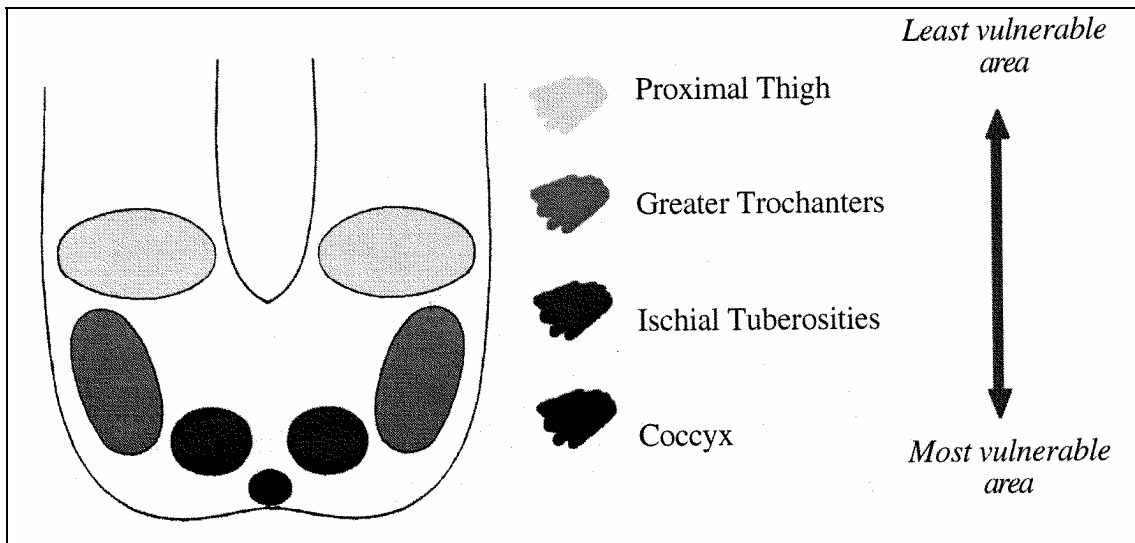

Figure 2. Map of relative vulnerability

Types of cushions

There are several general categories of cushions:

Custom contoured: Made to fit closely to the shape of the individual user

Generic contoured: Batch produced with some contouring to fit many people

Flotation: Can use air or fluid. This can be good for equalizing pressures but can also be unstable and increase the risk of catastrophic collapse.

Flat: A flat piece of resilient material, usually polyurethane foam.

Combination: Generic cushions can be modified using various materials and shapes to improve the pressure relief properties for an individual user. Where the clinical skills exist, this method can be useful in striking a balance between labour costs and positive outcomes.

Possible features of a contoured cushion

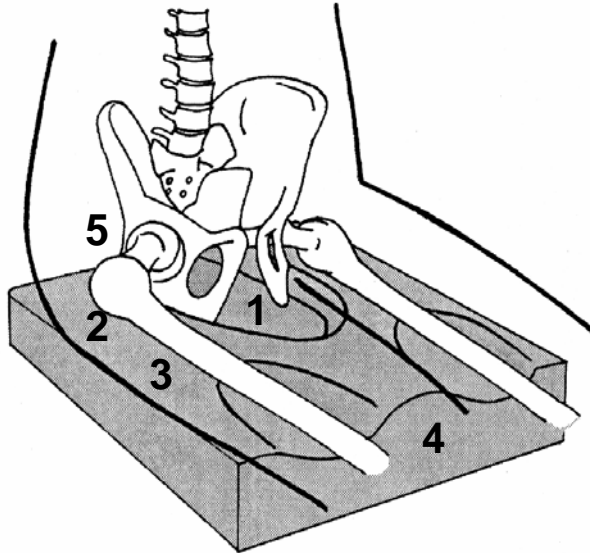

1. *Ischial recess*: A lower area under the pelvis which helps to reduce pressures under the ITs.
2. *Trochanteric shelf*: A surface to either side of the ischial recess which transfers some load from the ITs to the greater trochanter.
3. *Pre-ischial bar*: A raised area under the proximal thigh which helps to transfer weight bearing from areas at greater risk of pressure sores. This acts as a fulcrum, reducing weight at the ITs and trochanters when the knees are lowered.
4. *Abductor and adductor contours*: Contours in the front of the seat which help to reduce excessive abduction, adduction and internal rotation of the hip joint.
5. *Coccyx relief*: The coccyx normally does not touch the seat surface and should not support any weight. A relief can be created if a very slouched posture is present, resulting in pressure at the coccyx.
6. *Cushion cover*: A cushion cover should be water resistant or cover and cushion should be easily washed and tried. A spare cover and top foam can help ensure continuous cushion use.

Figure 3. Possible cushion features

Anthropometrics

Development of generic (batch produced) cushions will usually begin with size generalizations using existing databases mixed with locally gathered data. Some useful adult body dimensions are as follows:

Approximate distance between ITs centre to centre = 10 to 15 cm or 4 to 6 inches
Approximate distance between ITs outside to outside = 15 to 19 cm or 6 to 7½ inches
Vertical distance from ITs to greater trochanter is approximately 4 cm
(based on ADULTDATA 1998).

Foam firmness vs density

Density refers to the cell size and weight of the foam. The more dense a foam, the smaller the cell structure, the more it will weigh, the longer it will last, and generally the more it will cost.

Firmness refers to how hard or soft the foam is; very dense foam can be either very soft or very hard depending on the chemical formula or in mould pressure. Foam firmness must be

determined for various cushion components based on expected performance. A simple, low cost foam firmness tester can be made with basic tools and materials.

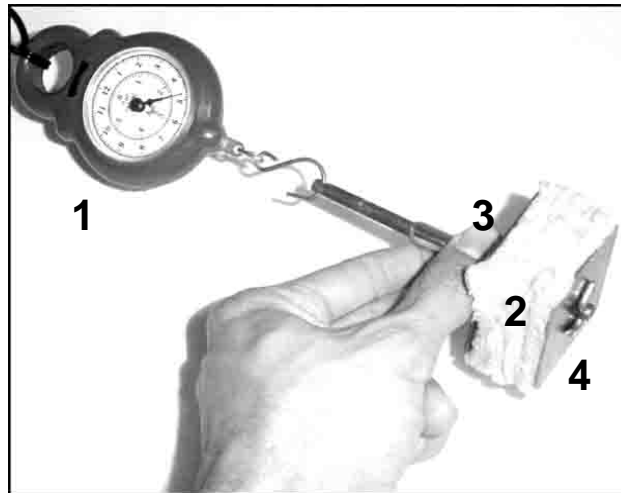

Figure 4. Foam firmness tester

Parts

1. Spring scale (10 kg)
2. 50 mm cube foam
3. Slide plate
4. Stop plate

Procedure

- Force required to compress the foam to 50% is recorded.

Foam firmness guide

- Cushion base foam 5 to 6.5 kg
- Cushion top foam 2.5 to 4 kg

Cushion cover

A cushion cover can negate some of the pressure relieving qualities of the cushion due to hammocking effects and the material characteristics of the fabric. Two approaches for cushion cover use and performance include liquid permeable and impermeable.

Liquid permeable with a spare washable top foam and cover

- Allows liquid (urine) to pass through the cover and into the top foam layer
- Cover is removable and washable
- Top layer of the cushion is removable and washable
- Spare cover and top foam can be used while soiled parts are washed and drying
- Base layer of foam is protected from damage

Impermeable/wipeable cover

- Cover will prevent liquid from reaching the cushion
- Will increase life of foam cushion
- Can be wiped off when soiled and used directly after
- May contain moisture near the surface and against users skin

Positive properties of a cover

- Allows air circulation to the areas at risk (ITs, greater trochanter)
- Stretches to prevent surface tension (hammocking).
- Cover material is thin enough that folds and wrinkles will not cause marking of the skin. In this case a loose fitting or pleated cover can help to reduce surface tension (hammocking)

Cushion selection based on need

The following example shows four cushion options (basic, basic plus, skin protection and protection plus). This type of multiple product systems can help to provide the appropriate cushion for each users needs. This example uses common parts to reduce production and cost burden.

Basic	Basic plus	Skin protection	Protection plus
			
<p>Consists of a 1.5 to 2 inch sheet of good quality foam.</p>	<p>Consists of a sheet of good quality foam and a firm base foam with slight ischial relief and abduction contours</p>	<p>Consists of a sheet of good quality foam and a firm base foam with deep thigh contour, ischial relief, and gluteal supports.</p>	<p>Consists of a sheet of good quality foam and a firm base foam with deep thigh contour, ischial relief, gluteal supports, and additional lift to provide deeper ischial recess.</p>
<p>Provides some increased comfort</p>	<p>Provides some increased comfort , stability and postural support</p>	<p>Provides pressure distribution, comfort and postural support</p>	<p>Provides pressure distribution and postural support with increased ischial relief</p>
<p>For persons with sensation at the sitting surface.</p>	<p>For persons with sensation at the sitting surface.</p>	<p>For persons with poor sensation at the sitting surface.</p>	<p>For persons with poor sensation at the sitting surface who has little tissue mass at the seat surface.</p>

Figure 5. Multiple product system

The design and features of a generic cushion depend greatly on the clinical tools and approach used locally; and visa versa.

Cushion assessment

Every wheelchair rider who has limited sensation at the sitting surface should use a pressure relief cushion. The following factors should be considered when assessing a wheelchair user for a new cushion:

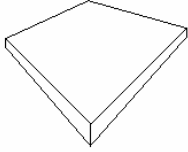
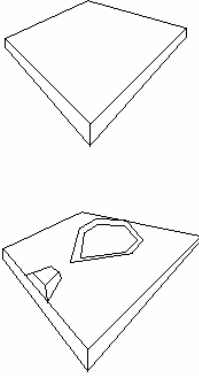
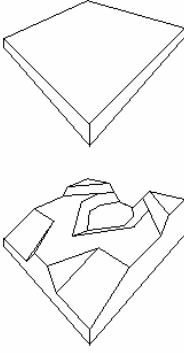
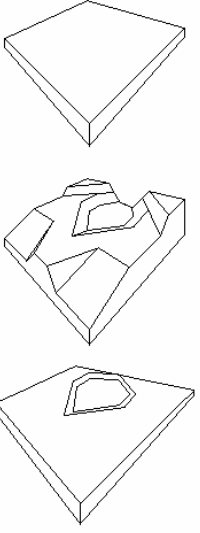
- History of skin problems or pressure sores (document location and size of previous or current sores and how they developed)
- Risk factors for the individual
- Bowel and bladder management and history
- Transfer method
- Wheelchair use pattern

Checking pressures

The following is an example of a simple, manual pressure measuring procedure which requires only the clinician's hands.

1. Ask rider to perform complete vertical pressure relief or “push up”
2. Place hand under back upholstery from behind so that finger tips are under bony prominence (Ischium, trochanter and coccyx if needed).
3. Ask rider to sit on fingers, face forward, and place hands on legs.
4. Evaluate and identify pressure level:
 - Level 1: Can wriggle fingers
 - Level 2: Fingers are pinched but can easily remove fingers
 - Level 3: Fingers are pinched and cannot be removed easily
5. If Level 2 pressure is present at any risk area, consider other factors (i.e., history of pressure sores, general health, and compliance). If factors increase risk, modify cushion.
6. If Level 3 pressure is present modify the cushion to reduce pressure:
 - Place one or more accessory “lift” foam layer under the cushion base
 - Cut base foam as needed to reduce foam under risk area
 - Check pressure again

There are examples of low to high technology pressure measuring tools which range from electronics to hydraulic to mechanical. Regardless of tools available, a manual pressure check method should be used to confirm and interpret results from the instrument.

Purchase and maintenance of high tech pressure mapping and even single cell pressure measuring tools can be prohibitively costly. One low cost solution is to attach a rubber balloon to the end of a tube. Fill the balloon with coloured water and measure the height of the displaced water (Figures 6 and 7).

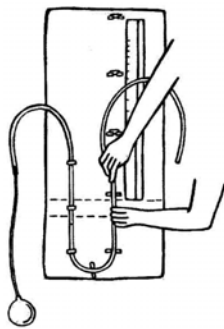

Figure 6. Balloon tester

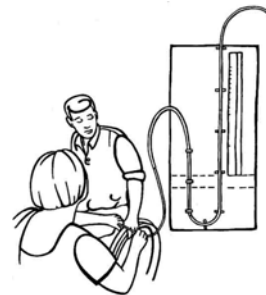

Figure 7. Balloon tester in use

Further work is needed to develop easy to use, low cost pressure measuring tools.

Cushion testing equipment and methods

Evaluating a particular cushion design as compared to other designs or to an agreed standard has been done in different ways in the past decade. Generally a standard indenter is used to simulate the human body sitting on a cushion. While loaded, the relation between the indenter and the cushion is evaluated. This can be done by interpreting the load pattern on a computer driven “pressure map” or by simpler methods as in Figure 10.

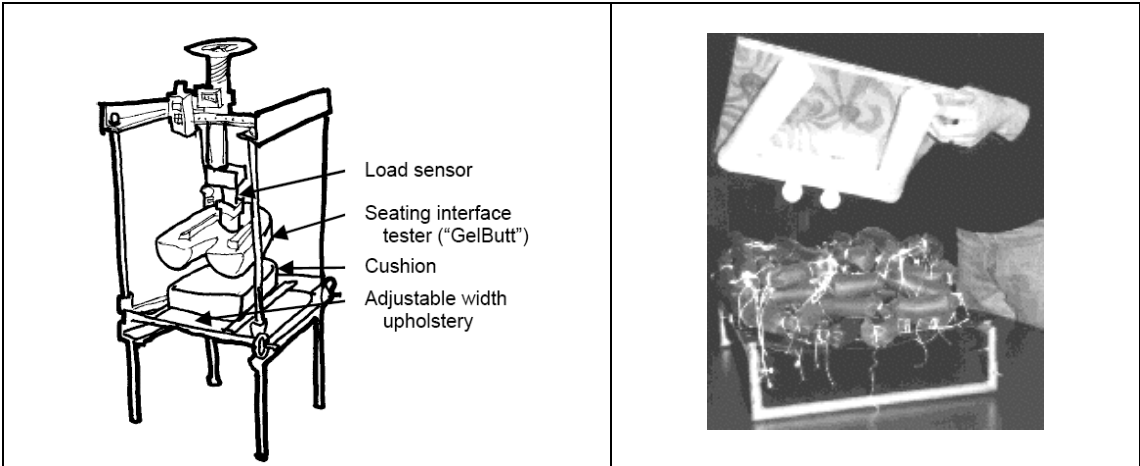

Figure 8. Lifelike gel cushion indenter and test rig from 2000 Beneficial Designs Inc. A computer driven pressure map is used to record relative pressures.

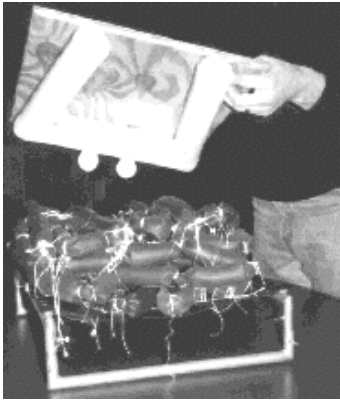

Figure 9. Cushion indenter from 1997 RESNA SIG 17 SoreButts Cushion Design Competition (Hadow et al. 1997) using PVC pipe and golf balls. Pressure map used to record pressures.

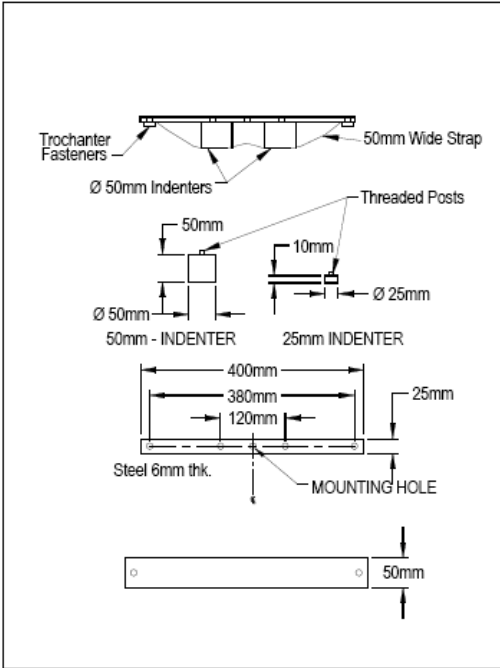

Figure 9. Contoured loading jig (CLJ). One of the test jigs used in ISO: 16840:2 DIS cushion (ISO standard) (Sprigle 2003). No pressure mapping is required. This test checks if, under specific loads, the indenters are in contact with the cushion and if the indenter has "bottomed out". This method may not be appropriate for evaluating performance of some floatation cushions.

Good cushion - low cost

Low cost cushions are not necessarily lower quality or lower performing products than expensive, high technology cushions. Figure 10 shows a pressure map comparison between sitting on a wheelchair with no cushion, an expensive cushion, and a low cost cushion. The latter is a production cushion from Sri Lanka made with a base of formed, rubberized coconut fibre or "coir". The coir cushion, developed by Motivation, costs US \$10.

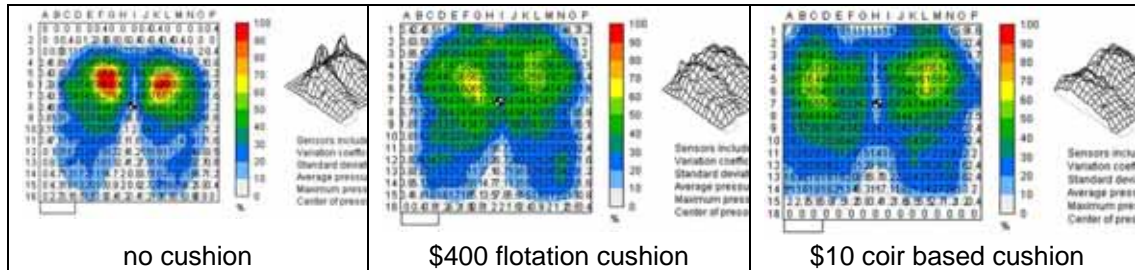

Figure 10. Pressure map comparison

Key points

- An inadequate pressure relief cushion is the part of a wheelchair that is most likely to cause serious injury or death.
- Areas of highest to lowest risk are: ischial tuberosities (ITs), greater trochanters, and proximal thigh. Coccyx is vulnerable but, unless very slouched posture is present, is not in contact with the cushion.
- Types of cushions include: custom contoured, generic contoured, flotation, flat, and combination.
- Features of a cushion can include: ischial recess, trochanteric shelf, pre-ischial bar, abductor and adductor contours, coccyx relief, and cover.
- Anthropometrics relative to pressure relief cushions for adults include: IT outside to outside = 15 to 19 cm. Vertical distance from IT to greater trochanter = 4 cm.
- Foams of different firmness can be used together in a cushion for best results.
- A cushion cover should not increase surface tension and should prevent liquid from pooling on the skin.
- Various cushion options should be available and used, case by case, depending on sensation level and risk of pressure sore development.
- Manual pressure check should always be used in provision of cushions.
- Simple equipment can be used to compare generic cushion designs to other designs and to an agreed standard.
- A high performance cushion does not have to be a high cost cushion.

Acknowledgement

Much of the material presented is kindly provided by Motivation Charitable Trust, UK. Many thanks also to others who have contributed to the ideas and approaches discussed here.

References

ADULTDATA.1998. Department of Trade and Industry, UK.

Haddow A, Shapcott N, Gonzalez J. 1997. Wheelchair cushion designs for developing countries: Project SoreButts. In: Proceedings of RESNA 1997 Annual Conference.

Sprigle S. 2003. Reliability of the ISO wheelchair cushion test for loaded contour depth. Assist Technol 15(2):145-150.

Products:

The role of user feedback in research and design

Jon Pearlman
Human Engineering Research Laboratories, University of Pittsburgh,
Pittsburgh, USA

Main Overview

Unlike typical product consumers, in general wheelchair users do not pay for their wheelchairs. This leaves them at a disadvantage in being able to demand better quality devices. Instead, the control of the type of wheelchair provided is commonly in the hands of the purchaser. In many cases, these purchasers are not well informed about the user's needs, the best way to provide the wheelchairs, and/or the important technical aspects of the wheelchair.

The fact that the user does not pay for his or her wheelchair can have several consequences. Firstly, if the service or facility providing the wheelchair does not prioritise (or have the training to understand) the user's needs, the user may receive a wheelchair not appropriate for their needs. Secondly producers can easily form monopolies or oligopolies which can thwart competition; this can cause both innovation and efficiency to suffer. Thirdly, the user may never be educated about or exposed to the type of technology which would best meet their needs and goals.

Strategies in the United States (US)

Several strategies are in place in the US to try to educate wheelchair users, protect them from receiving dangerous wheelchairs, help ensure that they have a role in influencing the type of wheelchair they receive, and to ensure they are provided with an appropriate wheelchair. Insurance providers (both public and private) require the wheelchairs provided to meet minimum technical standards and require that a clinician signs a prescription for the device. These requirements are slowly becoming stricter, with the recent suggestion that trained wheelchair providers be involved in every wheelchair fitting.

There are also mechanisms of consumer advocacy and education, such as the requirement that manufacturers provide the results of the technical standards testing if requested. Independent laboratories also test these devices and publish results to help inform the consumers about product performance. The government requires that adverse events that occur with products be reported and publicly available. This allows users and their advocates to learn about potentially dangerous products.

Lower limb prostheses

Similar to wheelchairs, there is a tremendous need for lower limb prostheses (LLP) in developing countries (~30 million according to the World Health Organization (WHO)). In contrast to wheelchairs, LLP technology and provision is largely professionalised, requiring certified prosthetists to provide the devices. The prosthetic appliance also needs to meet durability standards (ISO 10328), and field trial and follow-up protocols are in place to formally evaluate new devices to ensure they are functional and appropriate for the users.

The process of professionalising LLP provision took many years, but through efforts of the International Society of Prosthetics and Orthotics (ISPO), WHO and the United States Agency for International Development (USAID), along with other donors and stakeholders, much progress has been made to ensure the user is provided with the best device for their needs. This has been accomplished by developing best-practice guidelines, and performing independent field-testing, e.g. Jensen et al. (2004) and Jensen and Heim (2000), of devices, and continuing to work to streamline the technology and provision.

Examples of user-involvement in research and development

There are only a few examples of user's involvement in research and development (R&D) of wheelchairs in developing countries. The author was only able to identify five articles (Lysack

et al. 1999; Mukherjee and Samanta 2005; Mulholland et al 2000; Mulholland et al. 1998; Saha et al. 1990) which included user aspects in the evaluation and or design of wheelchair services. While this is a good start, all of these studies have drawbacks, and do not show conclusively what types of devices are appropriate for users; building research capacity in this field will take dedicated effort and time.

Much of the user involvement in the R&D process involves focus-groups and field-trials performed by the organisations developing wheelchairs for developing countries. These are formal or informal trials for users to test new devices to provide feedback to the designers and other stakeholders. In some cases, these trials can be very comprehensive, including wheelchair users keeping diaries, taking photos, and several home visits to record feedback from the user (Constantinescu 2007) (see p 231 of this report).

There are several ongoing studies which include wheelchair users in the R&D process. Brief descriptions of the studies are shown below:

Center for International Rehabilitation

Aim: Document and follow-up on wheelchair project in developing country to guide future projects.
Subjects: 100 experienced users, 18-65 years old
Protocol: Training: 6 day training of local physiotherapists and technicians
Subject Visit # 1: subject interview & assessment (by physiotherapist and technician)
Visit #2: interview by physiotherapist and technician; wheelchair inspection, wheelchair skills test
Subject Visit #3 - Week 10: Repeat all activities from Visit #2.

Human Engineering Research Laboratories, University of Pittsburgh

Aim: Investigate usage patterns (i.e., speed, distance) of users in different wheelchairs
Subjects: 10 WC users using hospital-type wheelchairs
Methods: Using non-invasive data-logging devices
Log distance, speed of user for 1 week in current (hospital-type wheelchair)
Fit and provide user with new custom-fit wheelchair
Log distance and speed for 1 week
User chooses which wheelchair they prefer

Human Engineering Research Laboratories, University of Pittsburgh

Aim: India Accessibility/R&D study
Gather accessibility information in and around the home in India, and use it to help guide WC design
Methods: 50 disposable cameras are given to wheelchair users in India
Users take photo of inaccessible places
A web-based questionnaire is used to enable stakeholders interpret the data and provide design ideas

Quality of evidence

Even though evidence of what type of wheelchair provision and technology are most appropriate is being compiled, conclusive evidence will require higher quality, more comprehensive studies. This is most obvious when categorising the types and literature is available with respect to its risk for bias. The table below lists a well accepted list of the quality of evidence (Hadorn et al. 1996) based on the type of research study performed. The order is from least to most subject to bias. In the second column, the approximate number of literature that has reported this evidence is presented:

Study Type	Number of Studies In Literature
Large (>100) Randomised Control Trial	0
Small (\leq 100) Randomised Control Trial	0
Cohort Study	2
Case Control Study	1
Poorly/Uncontrolled Studies	5
Expert Opinion	80

Clearly, the balance of the evidence is published in literature in this field is highly subject to bias.

Conclusion

Wheelchair users are commonly powerless to demand better technology because they typically do not pay for their own wheelchairs, and in many cases they are not educated about the range of technology that is available or possible. These issues have been addressed in many developed countries by enforcing technical standards wheelchairs should meet and that the devices are provided by clinicians knowledgeable in wheelchair provision. Adverse events and durability testing results for wheelchairs is also published regularly by the Government and independent laboratories to help educate wheelchair users and clinicians about the performance of commercially available devices.

Lower limb prosthesis (LIP) technology and provision in developing countries has similarly developed strategies to ensure user involvement and professionalised services to ensure the most appropriate devices are provided in a safe and effective manner. This has occurred through development of best-practices guidelines, certified training centres and curriculum, technical standards, and research and development protocols so that new LLPs can be rigorously evaluated.

The field of wheelchair provision in developing countries needs to draw from both the example of policies and advocacy presented in developed countries and the LLP technology and provision in developing countries. Users need to be an integral part of all rehabilitation and development of wheelchair technology to assure it is relevant, appropriate, and safe for their needs. Furthermore, objective outcome measures need to be identified and used to evaluate devices and service provision methods. These studies will also comparison across devices and service provision and help guide and streamline wheelchair provision in developing countries.

References

- Hadorn DC, Baker D, Hodges JS, Hicks N. 1996. Rating the quality of evidence for clinical practice guidelines. *J Clin Epidemiol* 49(7):749-754.
- Constantinescu S. 2007. Production: methods of production, test standards, quality control. In: Report of ISPO consensus conference on wheelchairs for developing countries. Sheldon S, Jacobs NA, editors. Copenhagen: ISPO. pp 231-236.
- Jensen JS, Craig JG, Mtaló LB, Zelaya CM. 2004. Clinical field follow-up of high density polyethylene (HDPE)-Jaipur prosthetic technology for trans-femoral amputees. *Prosthet Orthot Int* 28:152-166.
- Jensen JS, Heim S. 2000. Evaluation of polypropylene prostheses designed by the International Committee of the Red Cross for trans-tibial amputees. *Prosthet Orthot Int* 24(1):47-54.
- Lysack JT, Wyss UP, Packer TL, Mulholland SJ, Panchal V. 1999. Designing appropriate rehabilitation technology: a mobility device for women with ambulatory disabilities in India. *Int J Rehabil Res* 22:1:1-9.
- Mukherjee G, Samanta A. 2005. Wheelchair charity: a useless benevolence in community-based rehabilitation. *Disabil Rehabil* 27:10:591-596.

Mulholland SJ, Packer TL, Laschinger SJ, Lysack JT, Wyss UP, Balaram S. 2000. Evaluating a new mobility device: feedback from women with disabilities in India. *Disabil Rehabil* 22:3:111-122.

Mulholland SJ, Packer TL, Laschinger SJ, Olnet SJ, Panchal V. 1998. The mobility needs of women with physical disabilities in India: a functional perspective. *Disabil Rehabil* 20:5:168-178.

Saha R, Dey AK, Hatoj M, Poddar S. 1990. Study of wheelchair operations in rural areas covered under the district rehabilitation centre (DRC) scheme. *Indian J Disabil Rehabil* 1990:74-87.

Plenary discussion: Products

Chairman: Marc Krizack
Rapporteur: Kim Reisinger

For Hotchkiss & Constantine: Comment on ensuring quality of joining parts is consistent
Response: Quality control is never easy, initial testing (in 40+ countries) is simplified ISO testing with static loads, sometimes can do full ISO testing. Static load testing can give some indication of the quality control. Quality of welds is included as part of training, cut weld to check, and use destruction testing. Motivation checks quality control by cleaning frames and jig, and destroying to see consistency of welds. Worldmade products undergo quality control in Shanghai.

For Free Wheelchair Mission (FWM): comment on exposure of polypropylene of wheelchair to sunlight exposure

Response: UV protection is added, plus person in wheelchair adds protection by blocking exposure to sunlight.

For FWM: Can you really say that wheelchairs can cure pressure sores?

Response: The findings were a surprise but not completely; polio, congenital deformities (none with spinal cord injuries)

For FWM: Describe assessment and training and follow-up

Response: FWM does not distribute, they rely on partners to do this. Distributors are requested by FWM to do assessment, training and follow-up; partner organizations must have previous experience.

For Wheelchair Foundation (WF): Stated it is proud to have distributed so many wheelchairs but has it conducted follow-up to determine how many are still being used?

Response: Yes WF has conducted follow-up but there are difficulties as there is only a staff of 5 to carry out all activities. Much of the assessment is anecdotal; they have seen some still being used that were out since 2000, but also seen some failed after few months. Most feedback from partner NGOs is that the wheelchairs are still being used.

For WF: Served a lot of people by providing wheelchairs, which is commendable, what type of provision do you make?

Response: Like FWM, WF is dependent upon experiences of partners in country. All partners are pre-qualified. Sometimes it may take 5-6 months to distribute, in these situations it is an impossible task.

For FWM: Your claim is that you provide good wheelchair to people, does it have a cushion? What about weather?

Response: Yes, have provided cushions with wheelchairs for the last year. We try to avoid issuing people with Spinal Cord Injuries with wheelchairs as much as possible. The extra mobility that people achieve once they have a wheelchair is what contributed to pressure sores healing not wheelchair or type of seat.

Comment: There have been comments in favour of lowering the cost of wheelchairs; this will put more in the field and more people will access a wheelchair. However, as we go on to define the standards should we compromise on the cost or appropriateness?

Comment: There is a need for standards and performance and pressure distribution characteristics. We need proper standards to work towards. ISO standards were written for the industrial world, and are not appropriate for application in the developing world. Would manufacturers be interested in more stringent standards because they are needed?

For WF: Well established local partners can produce wheelchairs and provide a service, WF's strength is in the money they can raise, would it consider partnering with local service providers to distribute wheelchairs?

Response: WF's cost is US\$150 for everything, including overheads. WF has looked at partnering but its current distribution model is what works best for them now.

Comment: FWM would be happy to work with local partners to distribute their wheelchairs.

For Øderud: In Zimbabwe 15% of people were over 60 years at onset of disability, why so high?

Response: Might have been a higher age population in Zimbabwe at that time.

Postural support and cushions

No discussion occurred on this topic due to time constraints.

Production: Methods of production, test standards, quality control, cost, sustainability

Ray Mines Motivation UK, Bristol, UK

Definitions

- *Quality*: the production quality of a wheelchair: quality of components, materials, workmanship and finish.
- *Appropriate design*: a wheelchair which has been designed for long-term, durable use in demanding environments and climates (including local repairs and spares).
- *Sustainable wheelchair production*: production which has a stable economic future without creating damaging side effects for the environment and society.

The scale of wheelchair production

There are many hundreds of organisations producing wheelchairs all over the world. For the purpose of this paper they have been grouped by the number of wheelchairs they produce on average each month and a simple example of what type of facility this might relate to has been given:

Origin	Volume	Example
National	Small (<50/month)	Small workshops
	Medium (50-500/month)	Larger workshops/small factories
	Large (>500/month)	Large industrial supplier to domestic market
Imported	Small (<50/month)	Workshop supplying neighbouring country
	Medium (50-500/month)	Factory exporting regionally or globally
	Large (>500/month)	Large industrial supplier exporting globally

There are examples of wheelchair production at all scales, both distributing their products nationally and exporting them to other countries. From experience it is known that the most common type of production is small scale workshops in developing countries building up to 50 wheelchairs a month. In fact many produce less than 25 wheelchairs a month. In contrast by far the largest volume of wheelchairs is being produced by large industrial manufacturers in China, several capable of producing 10,000 per month. These are being distributed in the enormous domestic Chinese market and exported all over the world.

Comparing the smallest and largest producers of wheelchairs illustrates the central issues of the topic by highlighting the two extremes of the situation. It should be noted that there are good and poor examples at both extremes. However, the overwhelming current trend is that large volume manufacturers do not produce (and their customers do not insist on) good quality, appropriate wheelchairs for long-term use in developing countries. Instead industrial manufacturers generally provide large volume purchasers with the cheapest (US\$30-50) specification of wheelchair possible.

It is worth noting here that it is fairly rare for the large volume manufacturers to sell directly into a developing country. Sales usually happen via agents or resellers such as pharmacies. Therefore when we talk about issues relating to the provision of wheelchairs from large volume producers, we are really talking about their customers; the purchasers of wheelchairs. Industrial manufacturers will make whatever their customers demand; if the customer wants the cheapest wheelchair available, the manufacturer will supply that (with all its drawbacks). Therefore customers are directly responsible for the quality and design of the products that they choose to purchase.

Small workshops are naturally more connected to the needs of wheelchair users, often employing or being wheelchair users themselves and living in the community they serve. They have better opportunities to cooperate with local service providers or are the local providers themselves. Large volume producers (and their customers) are generally remote and disconnected from the end user of their products. While there are many small local workshops that produce poor quality wheelchairs there are also many that produce very appropriate, well made products, that can be repaired locally and modified to better suit users' needs. Large volume producers (and their customers) generally choose not to build long term service providers, invest in the training of local staff, provide a repair service or supply of spare parts and provide a more individual service that better meets the needs of users. For many large producers and the organisations that purchase from them, supplying a basic wheelchair is the end of their participation.

As a community we now have unprecedented access to the large scale manufacturing resources of China and the Far East, yet we are making little use of the best opportunities open to us. The economies of purchasing materials and parts in larger volumes are only part of the picture. With good design there are numerous benefits of large volume production for wheelchair users; higher technical precision parts make it possible for the product to be fitted more individually for each user, better quality control practises mean that each wheelchair is more consistent, and better quality and more sophisticated materials and processes (making it possible for instance to make cheap pressure relieving cushions).

However, these advantages are completely negated if we do not address the issues of appropriate design, repairs, spare parts and service provision. Cost must always be related to benefit, and must never be the primary consideration. Any wheelchair which is given to a wheelchair user which it is not suitable for is a waste of the community's resources. That wheelchair may have been purchased cheaply, but it is now worthless to the end user and, worse, may actually cause them significant harm.

The real costs of industrial scale production are generally ignored and externalised by customers. There are no capital start-up costs when purchasing large numbers of wheelchairs from an industrial manufacturer, only the per unit product cost. The real costs do not yet have economic value in society and are largely forgotten. Over the last three years during visits to 14 large manufacturing facilities in China and the Far East blatant pollution, illegal employment practises, dangerous working conditions and the production of thousands of poor quality wheelchairs have been witnessed without any regard for the needs of the user whatsoever. We have witnessed thousands of broken imported wheelchairs piled high in hospital store rooms and rubbish tips. Far from being the cheapest model this would in fact seem to be the most wasteful and costly when all things are accounted for. The consideration of environmental and social criteria alongside economic is as essential and relevant in our field as it is for the wider community.

In order to address the huge need facing us, as a community full advantage must be taken of the benefits of purchasing and producing wheelchairs in larger volumes, but great efforts must also be made to protect the wider community from the negative social and environmental side-effects of industrial production. New and better ways must be found of stimulating innovation and supporting national producers to compete with cheaper imports. It should be remembered that the huge need for 20 million wheelchairs world-wide is for **affordable** but **appropriate** wheelchairs that are **durable** in developing country environments.

Presentation Slides

Small volume production

Strengths:

- Increased opportunity for appropriate product
- Local source of repairs and spare parts
- Increased opportunity to work closely with local service providers

- Individual modifications made to order
- Lowest capital start-up and overheads
- Employment opportunities for local disabled people
- Part of the community they serve

Challenges:

- Survival: rely on selling products and receiving donations to survive
- Maintaining production quality
- Local materials/ low technology
- Technical skill level
- Management skills
- Identity: "are we an NGO or a business?"
- Remaining competitive against imports
- Low volume + expensive materials = high product cost
- Often not scalable to meet larger demand (generally produce < 600 wheelchairs/year)

Large volume production

Strengths:

- Economies of scale; producing between 6,000 and 120,000 wheelchairs/year
- Purchasing power
- Highest volume + lowest price materials and parts = lowest product price
- Opportunity for best practise quality control
- Opportunity to use high quality industrial processes
- Proximity to other suppliers
- Opportunity for consistent precision parts
- Existing commercial wheelchair suppliers; purchasers do not fund initial high start-up capital costs
- Large volume production

Challenges:

- Industrial suppliers designing and producing appropriate wheelchairs
- Unfortunately often opportunities for best practise are replaced with cheapest possible solution to maximise profit
- Maintaining good working conditions
- Understanding user issues
- Must distribute large numbers to be viable
- Being responsible for whole product lifecycle
- Connecting to local service providers
- Investing in local skills development
- Ensuring supply of replacement parts

Product testing

- Benchmark of minimum performance
- Raise general quality in whole market
- Common international standards – increase competition, exclude poor products
- National governments must adopt standards
- ISO 7176 wheelchair standards – high start-up capital costs of equipment
- Low cost alternatives to ISO testing:
 - Non-ISO national standards
 - Whirlwind ISO tests
 - Motivation tests
 - User trials
- Stakeholders combining experience of low cost strength and durability testing and user trials, to create WHO guidelines for best practise

Quality control

- Key factors of quality control (QC) at any scale:

- Management understanding benefits of QC
- Organisation of workplace
- Investment in staff training
- Disciplined implementation of procedures
- Common QC practices:
 - Check jigs
 - Random sample inspection/testing
 - AQL (acceptable quality level)
 - SPC (statistical process control)
- Formal quality systems more affordable by large factories
- However large factories can produce inconsistent, poor quality products too when disorganised
- Implementing QC – an ongoing challenge particularly for small workshops

Cost

- Industrial production = lower product prices ↓\$
- ...but inappropriate wheelchair = overall waste of resources ↑\$
- Organisations donating wheelchairs often focus on product cost above quality of service, durability of product, etc
- Government tender systems often purchase cheapest product regardless of other criteria such as appropriateness, durability, quality, etc
- Whole life-cycle costs must be considered
- Cost vs benefit: products must meet users' needs
- Cost should never be the primary consideration

Sustainability

- Generally small workshops:
 - Good social impact ↑
 - and relatively low environmental impact ↑
 - but higher product cost and generally struggling financially ↓
- Poor quality large volume industrial production:
 - Low product cost and commercially viable ↑
 - but exploitative working conditions, poor quality products ↓
 - and environmental pollution, poor health and safety ↓
- What if we could combine the benefits of both?
- The most sustainable model overall could be supporting more 'medium volume' producers (600 – 6,000/year) that achieve economies of scale whilst controlling negative social and environmental side effects.

Challenges for the future

- Putting the user first – designing appropriate wheelchairs for long-term use
- All stakeholders agreeing on minimum product standards – creating level playing field
- Improving product quality by increasing use of product testing and quality control
- Supporting small/medium producers to improve quality, price and financial sustainability
- Large donors of wheelchairs working with local organisations and other stakeholders
- Not ignoring and externalising real costs of industrial production:
 - Maintaining good working conditions and environmental practises
 - Considering whole product lifecycle costs
- Produce affordable, appropriate and durable wheelchairs in larger volumes

Production:

Experience in production facilities: local: MADE, Uganda

Fatuma Acan
MADE, Kampala, Uganda

Objectives

There were two main objectives for starting wheelchair production in Kampala, Uganda. Firstly, given the experiences of wheelchair users in Uganda, it was recognised that mobility is a basic need and in order for a person with a mobility disability to reach their potential there is need for him or her to have the right mobility equipment to suit his or her disability and living conditions. Mobility Equipment by Women Entrepreneurs (MADE) was therefore formed with the sole purpose of providing mobility equipment appropriate for the personal needs of people with disabilities. The second objective was to create job opportunities for disabled people within the wheelchair workshop itself.

Achievements

Although records of how many wheelchairs have been produced have not been kept, the figure is estimated to be more than 500 wheelchairs. Despite this being a small number, the organisation prefers to grow slowly, grasping all the knowledge it takes to build a good wheelchair. Vocational training inside the workshop has enabled the workers to learn many new skills.

The professional training received by the workshop manager at the Tanzania Training Centre for Orthopaedic Technologists (TATCOT) has not only taken MADE many miles extra in the wheelchair industry but has also given them the confidence to take the right decisions regarding wheelchair production.

Challenges

Since its inception in Uganda, the local wheelchair industry has gone through challenges in marketing, funding, material supply and sourcing production equipment.

Marketing

The wheelchair market is unique in the sense that the consumer does not play an active role in choice or purchase of the product. Since the majority of our clients cannot afford to pay for their wheelchairs themselves, they are forced to look for sponsors who invariably do not seek for their choice to choose the right product for themselves.

The second drawback faced by the local producer is the fact that wheelchairs from developed countries are imported despite their inappropriate design for the Ugandan terrain. These are produced using high-tech materials such as aluminium alloys, titanium and carbon fibre which wheelchair users naturally prefer to the well designed and strong but not very sparkling local wheelchairs.

Another setback for MADE's products is the lack of awareness about the potential for mobility. People with disabilities, their relatives and many stakeholders involved in providing mobility do not have much knowledge about wheelchair provision and its positive and negative effects on the lives of people with disabilities. This affects local production very much as wrong decisions will often be made in choosing products.

Funding

Although the local wheelchair workshops in Uganda have been run as non-profit organisations since their inception, many funding agencies and donors do not see the need to support their efforts. Hence funds for the correct wheelchairs have always not been easily available. Many funders assume it is more important to fund advocacy initiatives rather than mobility equipment, yet as mentioned earlier, the potential of a person with a mobility disability can only be reached with the provision of an appropriate mobility device.

Production equipment

The production equipment used in wheelchair production in Africa is not always up to date. This constraint greatly affects the quality of the products produced and limits production speed. Some sponsors worsen the situation by adding time pressure, and in a bid to meet their requirements some wheelchair components are contracted out to metal workers who often produce components that do not meet professional standards.

Materials

Most of the materials for the wheelchair production are locally available but as small workshops are only able to purchase in small quantities they are forced to buy at general prices including heavy taxes; affecting the costing and pricing of the wheelchair.

Acceptance of wheelchair technologists by medical professionals

The last challenge to note is the negative attitude of some medical professionals towards local wheelchair technologists in Uganda. As the profession is relatively new, many medical professionals do not believe wheelchair technologists are capable of prescribing wheelchairs. However, if wheelchair users are forced to depend on prescription of wheelchairs by hospitals, local producers will also need to work in hospitals which in the case of Uganda will limit many users from accessing wheelchairs.

**Production:
Experience in production facilities: regional: CIR, USA +
Worth Trust, India**

**Kim Reisinger
CIR, Chicago, USA**

Introduction

It is estimated that there are twenty million people with disabilities in need of wheelchairs worldwide. Although there are currently several organisations that provide wheelchair assistance internationally, these organisations are generally divided between two implementation models: mass distribution and local manufacture. Some of the benefits inherent in the local production model include ongoing service provision for the wheelchair user and the employment of local residents. The primary benefit of mass production is high product volume at low cost. While each of these models has specific advantages, neither appears to be ideal for developing a sustainable wheelchair infrastructure that meets the needs of wheelchair users in low-income and post-conflict countries.

CIR's wheelchair provision strategy

Recognizing that the three central components of a sustainable, long-term wheelchair programme are reasonable cost, sturdy design, and a local network for distribution, training and repair, CIR's Wheelchair Programme combines the best features of the two existing models. It is comprised of central fabrication, regional distribution, and local service provision. Through central fabrication, it is possible to achieve some of the cost benefit and product volume associated with mass production. Manufacturing wheelchairs and delivering them as kits to specific regions still requires a local infrastructure. The basic outline of the programme is centralized manufacturing of wheelchair kits, which are then assembled and distributed by trained personnel at existing NGOs at the local level. Each kit contains all the components necessary to fully assemble a wheelchair, plus the materials required to fabricate a custom seat cushion for the user.

By centrally manufacturing the wheelchair kits, CIR's Wheelchair Programme allows for the production of more wheelchairs – up to 500 per month, more if a mass production facility is utilized – than grassroots programmes, which produce on average 30 to 40 chairs in that same period of time. It also keeps the cost of the wheelchairs affordable through several factors. Not only will economies of scale decrease the cost of production, the kit design reduces shipping costs over that of a fully assembled wheelchair.

Partnering with existing local organisations and providing training for the individual practitioners are critical components of CIR's strategy. Service providers receive training on assessment, and the assembly and fitting of the wheelchairs. They are also trained on the use, repair, and maintenance of the wheelchairs. In addition, they receive instruction on how to train the user on use and maintenance of the wheelchair. A team of two individuals, one technician and one physiotherapist, are trained on all aspects of appropriate service provision for the CIR-Whirlwind wheelchair. The technician focuses primarily on assembly and adjustment of the wheelchair while the physiotherapist focuses primarily on user assessment, fitting and training. With an interdisciplinary team of trained practitioners providing service, wheelchair users receive a wheelchair that is configured to their specific needs. As such the wheelchair will serve to maximize their independence as a mobility device that is safe, comfortable, functional, and efficient. Rather than draining resources from local organisations making sustainability more challenging, this approach maintains local participation and ultimately builds capacity.

The CIR Wheelchair Programme also benefits from a wheelchair design that is technologically appropriate for the regions to be served. That is, the wheelchair was designed, in collaboration with Whirlwind Wheelchair International (Whirlwind), San Francisco, CA, in a manner consistent with the region's materials and human resources. The CIR-Whirlwind wheelchair was designed to be durable on rugged terrain, and it can be adjusted to

fit a wide-range of individuals with varying degrees of experience. The wheelchair is made from materials readily available in the region and is easily repaired with a minimum of tools and equipment. Unique design features of the CIR-Whirlwind wheelchair include an innovative telescoping X-brace that provides seat width and height adjustability allowing a custom-fit wheelchair for each individual, an extra long wheelbase for stability with no loss of manoeuvrability, and wide solid rubber front casters that can roll over rocks and rough terrain more easily than the narrow, tubular conventional caster wheels.

CIR's Wheelchair Program began in early 2002 following a regional assessment in Afghanistan and Pakistan. Initially, an 18-month timeline was proposed to complete all aspects of the pilot research project inclusive of design, production, training and distribution, and follow-up assessment of the wheelchair. Figure 1, depicts the timeline for completing the project, including those aspects that were delayed, mainly due to instability in the region. Some of the challenges associated with establishing regional wheelchair production and distribution coupled with local service provision in an unstable region are presented. Advantages of this approach and a summary of recommendations, based on lessons learned, conclude this paper.

Anticipated & actual timelines	'01	2002				2003				2004				2005			
	Q4	Q1	Q2	Q3	Q4	Q1	Q2	Q3	Q4	Q1	Q2	Q3	Q4	Q1	Q2	Q3	Q4
Regional assessment																	
Design & production																	
Identify manufacturer		X								WORTH							
Identify distribution partner		X												KOO			
Initial design & testing																	
Prototype & drawings to mfg					X					Drawings only							
Iterative manufacturing & testing									P1	P2	P3						
Manufacturing 100 WC kits																	
Shipping to Kabul																	
Training for service provision																	
Develop training module set																	
Protocol for training & field study										X							
Research study																	
Conduct training workshop												X	X				
Field Study: 3-, 10-week follow-up																	
Extension: 9-, 15-month follow-up																	2006 [^]

Figure 1: "x" indicates that the activity could not be conducted due to instability in the region, and was rescheduled

Identifying a partner for production

The CIR intended to launch its wheelchair programme in the Southern Asia region, with initial distribution occurring at several locations in Afghanistan. The CIR-Whirlwind wheelchair is designed for production and repair using many manufacturing tools that are commonly found

in bicycle production facilities, as well as wheelchair production facilities. The initial demand for production was estimated at 100 wheelchairs per month, with a long-term scale-up to 300-500 per month. With these distribution criteria several possible production facilities were considered.

Initially, a bicycle factory in Lahore, Pakistan agreed to manufacture the wheelchair kits. It was considered an ideal facility because of their experience, proximity to regional distribution sites, use of materials and supplies available in the area of distribution, and ability to meet manufacturing demands. The evaluation trip for the delivery of the sample CIR-Whirlwind wheelchair and fabrication of a prototype chair at the factory had to be cancelled due to security issues; instead, the sample wheelchair and drawing set were shipped to the factory. Communication and interaction with the factory in Lahore, Pakistan continued to deteriorate due to the ongoing conflict in the region, and eventually ceased before CIR could receive a factory produced prototype. Due to the unanticipated effects of regional conflict and limited communication, CIR identified a new partner for production.

The Workshop for Rehabilitation and Training of Handicapped (WORTH) Trust in Katpadi, India entered into partnership with the CIR for the production of the CIR-Whirlwind wheelchair. The WORTH Trust has provided vocational training and employment for individuals with disabilities in India since 1973. WORTH Trust has long-term stability as a wheelchair manufacturer. Furthermore, it had a secondary facility that could be utilized for long-term production of higher numbers of wheelchairs. Approximately 90% of their workers who manufactured the wheelchairs are people with disabilities. Due to its long-standing history and wheelchair manufacturing capabilities, WORTH Trust was an ideal partner.

Production and shipping

Without a sample CIR-Whirlwind wheelchair, WORTH produced the first prototype (P1) from the drawing set alone, and shipped the wheelchair to Whirlwind for evaluation and testing. WORTH opted to outsource the manufacturing of the front caster wheels to a local rubber factory, significantly reducing the cost of this component. Visual and mechanical inspection of the wheelchair identified several issues, including improper assembly and inadequate strength of the axle bolts. Some design improvements to the x-brace assembly also required communication with the manufacturer. Subsequently, a trip to the WORTH factory was made in January 2004 to oversee design and manufacturing improvements.

During a 1-week working session in January 2004 at the WORTH factory, and using the designer's wheelchair as a sample, the jigs and fixtures required for production of the wheelchairs were fabricated. The site visit was also utilized to introduce efficient production methods, and to identify and test local materials as replacements for those parts that failed the testing at Whirlwind. Finally, the brakes and seat and backrest patterns were copied from the designer's wheelchair because these components had changed since the original prototype was produced.

During the site visit, two additional prototype wheelchairs (P2a, P2b) were manufactured. One was brought back to Whirlwind for further testing, although its surface had not been properly painted and finished; the second one was painted and then sent to CIR for testing and use in preparing the training materials associated with assembly, fitting, and repair and maintenance of the wheelchair. Following the tests at Whirlwind, additional recommendations and design changes were made and communicated to the WORTH Trust. These included modifications to the brake assembly and brake catch, and strength and material requirements of the seat and back fabric.

The WORTH Trust produced a final pre-production prototype (P3), but due to time constraints and scheduling, testing of this prototype was conducted on-site at the factory using Whirlwind's extended ISO testing for wheelchairs used in developing countries. The wheelchair withstood all of the required tests and was approved for production by the CIR. Over a 1-month period, in June 2004, the Worth Trust produced 109 wheelchairs and cushions. Nine of the wheelchairs were provided to ensure availability of replacement components should the need arise. CIR deferred to WORTH for packaging and shipping; the wheelchairs were packed as kits, with some sub-assemblies, in Styrofoam frames within

cardboard boxes. Approximately one third of the boxes, made from single wall cardboard, were damaged during shipping. Securing the frame and sub-assemblies within the Styrofoam frame prevented any lost or severely damaged parts.

Shipping of the wheelchairs to Kabul, Afghanistan presented a different set of challenges. Instability at the India/Pakistan borders prevented ground transport. Shipping time was too unpredictable using cargo ships to Dubai followed by air transport to Kabul, or by cargo ships to Karachi followed by ground transport to Kabul. Eventually, shipment from India to Afghanistan via air transport was utilized. Although it was very expensive and more than doubled the per chair cost, it was the only way to meet the already delayed timeline. Some additional delays in shipping the wheelchairs resulted from an unexpected trucking strike in India.

CIR's Field Operations Manager visited Afghanistan at the time of the delivery to finalize arrangements for the field trials and to store the wheelchairs. Due to security reasons and a deadly car bombing in Kabul, distribution of the wheelchairs for field trials was postponed until the security situation stabilized. One of the wheelchairs was brought back to the CIR laboratory and further tested. The CIR found that the upholstery used for the seat backs and bottoms, although identified as Cordura, did not have the same strength characteristics as that found in the United States. No equivalent could be found in India; CIR located Cordura material in Korea and arranged for shipment to WORTH in India. WORTH manufactured replacement seat backs and bottoms, and shipped them to Afghanistan for replacement on the wheelchairs.

Regular communication between CIR, WORTH and Whirlwind was crucial to quickly address issues with production as they arose. The WORTH Trust was extremely responsive to CIR's requested changes throughout the production process. Some recommendations regarding establishing a regional wheelchair production facility are presented below.

Identifying a partner for local service provision

CIR's Wheelchair provision strategy couples regional production with local service provision. This ensures that the wheelchairs are distributed in an appropriate manner with custom fitting and training by trained wheelchair service staff. It also helps to build and maintain local capacity and long-term sustainability. A local disability organisation initially agreed to participate in the field study and distribute the CIR-Whirlwind wheelchairs at their facilities in Kabul and Jalalabad. However, following conflict in July 2004, CIR decided to collaborate with the Ministry of Martyrs and Disabled (MMD) because they had more resources available that better suited the needs of the study. The MMD helped to identify the local project manager, translators, and candidates for technicians and physiotherapist who would receive training on appropriate service provision and distribute the wheelchairs. The MMD also identified 200 potential wheelchair recipients. During additional delays, due to elections and ongoing conflict in the region, the Kabul Orthopaedic Organization (KOO) became another collaborating organisation for the project. The KOO in Afghanistan is a centre that provides rehabilitative services in, orthotics, prosthetics and physiotherapy. The KOO, established in 2004, is a welfare organisation that is half governmental and half non-governmental. It serves vulnerable individuals including people with disabilities of all ages. Partnering with existing local organisations with resources and knowledge of people in need of wheelchairs greatly facilitated the establishment and implementation of the wheelchair services and distribution.

Implementation of wheelchair service provision – pilot programme

In August 2004 CIR's Field Operations Manager visited Kabul to secure delivery and storage of the wheelchairs, and worked in collaboration with the MMD to finalize the preparations for this activity. The protocol was reviewed with the local project manager and project coordinator, the training modules were translated into Dari and Pashtu languages, the technicians and physiotherapists were interviewed, and potential wheelchair recipients were identified. Following a bomb attack in Kabul it became evident that CIR could not send the remaining three members of the technical team required to conduct the training workshop. During the delay, the CIR worked with the MMD to recruit a Project Manager, three physiotherapists and three technicians, all native Afghans, in Kabul. The Research Coordinator came from India where he had previously managed the production of the study wheelchairs.

The field study began in June 2005 when CIR and Whirlwind staff provided a six-day training workshop for local physiotherapists and technicians in Kabul. Each physiotherapist was partnered with a technician for the training workshop and implementation of the field study. Each interdisciplinary team received hands-on training on the assembly, adjustment, use and repair of the study wheelchair, as well as on assessment, fitting and training of the individual subject (wheelchair user). Training manuals were provided to each participant in Dhari, Pashto, or English.

One-hundred wheelchairs were provided to subjects in Kabul during June and July of 2005 (Armstrong et al. in press). Each subject was seen for follow-up evaluation at 3-weeks and 10-weeks from the date when they originally received the wheelchair. During the field study, the technicians and physiotherapists worked in interdisciplinary teams to assemble the wheelchairs, assess the needs of individual subjects, adjust the wheelchairs and seat cushions for each subject, and readjust and repair the wheelchairs and cushions as needed. In addition, each subject underwent a skills assessment and training on the use and maintenance of the wheelchair, and they were provided with a user's manual in Dhari or Pashto, as well as a tool kit.

Subject retention rate was 98% for the first follow-up visit at three weeks and 90% for the second follow-up at ten weeks. At each follow-up appointment, the wheelchair was inspected and adjusted or repaired as needed, and the wheelchair user was interviewed regarding his or her experience with the CIR-Whirlwind wheelchair. This field study served to identify both the strengths and deficiencies of the wheelchair. Overall the CIR-Whirlwind wheelchair performed very well. The deficiencies identified were, in most cases, anticipated and can be resolved in subsequent productions of the wheelchair. Relative to subject responses provided in the interviews, the study wheelchair was consistently ranked highly with regard to ease of propulsion, stability, transportability, seating comfort, and appearance. Adjustments made to the wheelchairs at the two follow-up visits were minimal and were typical for improving the fit and function of any manual wheelchair.

CIR extended the study into 2006 to better evaluate the wheelchair performance in the long term (at 9-months and 15-months) and to better understand how the wheelchairs were being used by the subjects. It should be noted that only experienced wheelchair users were recruited for the original field study in 2005. This was done to ensure that feedback was provided by subjects who had prior experience using a manual wheelchair. As such, many of the subjects already had wheelchairs. After nine months, 62 of the 89 subjects interviewed (70%) continue to use the study wheelchair. The remaining 27 subjects no longer use the study wheelchair and have returned to using their original wheelchairs. In many cases these are hand-pedalled tricycles which can be more efficient for travelling long distances. In general, subject feedback from the follow-up interviews at 9-months indicated that the study wheelchair was performing very well. It was consistently highly ranked by subjects in the areas of seating comfort, stability, appearance and transportability.

Conclusions

CIR's regional approach to wheelchair service provision offers several advantages over other approaches. Compared with local production and service provision, central fabrication for regional distribution realizes manufacturing cost savings, greater numbers of wheelchairs, and better quality and uniformity of the wheelchairs. The average per chair cost for manufacturing (including start-up costs), for the first 109 wheelchairs, using a regional production approach is approximately USD\$110. In addition, there is no need to set up local production shops at additional expense and time. Partnering with existing NGOs and providing training on wheelchair service provision is a cost-effective alternative to setting up local production and service provision shops. Although this approach cannot compete with the number of chairs that can be produced using mass production methods, it helps to build and maintain local wheelchair service provision by partnering with local, NGOs and/or government organisations.

Recommendations for regional wheelchair production coupled with local service provision:

Considerations when selecting a partner for production:

- 1) Location within region
- 2) Chair design – what types of facilities can produce chair (e.g. bicycle factory, wheelchair factory)?
- 3) History/stability of organisation and region
- 4) Resources available, ability to outsource if necessary
- 5) People with disabilities employed at facility
- 6) Communication abilities (phone, fax, email)
- 7) Shipping capabilities

Suggestions for efficient production:

- 1) Regular communication
- 2) Provide component and assembly drawing set that has been verified (dimensions checked)
- 3) Provide sample wheelchair to factory
- 4) Provide jigs, dies and fixtures if possible, or provide manufacturing specifications and drawings
- 5) Conduct site visit early to deliver drawings, wheelchair, and jigs, and review drawings and materials – confirm availability of purchased parts and materials
- 6) Consider outsourcing components
- 7) Provide specific strength and material requirements, provide manufacturing specifications and test methods as possible
- 8) Make sure that the wheelchair can be tested appropriately prior to the manufacturing by the manufacturer or preferably the designer or main organisation
- 9) Provide tool kits for maintenance with each wheelchair
- 10) Ship equipment and supplies early in case goods are lost in transport or delayed in Customs
- 11) Allow extra time for unanticipated delays

Suggestions for implementing local service provision:

- 1) Partner with local organisation(s) having knowledge of individuals needing wheelchairs
- 2) Partner with local organisation with facilities for storage of wheelchairs, and fitting and training of wheelchair users
- 3) Conduct training workshops to ensure service personnel are trained to provide proper services
- 4) Provide training materials in local languages for education and reference

References

Armstrong W, Reisinger KD, Smith WK. In press. Evaluation of CIR-Whirlwind wheelchair and service provision in Afghanistan. Special Edition Disability and Rehabilitation on Rural/Developing World Rehabilitation.

Acknowledgements

CIR Project Staff, Chicago, IL; Whirlwind Project Staff, San Francisco, CA; Field Study Staff; WORTH Trust, Katpadi, India; Ministry of Martyrs and Disabled, Kabul, Afghanistan; Kabul Orthopedic Organisation, Kabul Afghanistan; Sandy Gall Afghanistan Appeal, Kabul, Afghanistan.

This project was funded by NIDRR of the U. Department of Education under grant awards H133E980003 and H133E030017.

**Production:
Experience in production facilities: global: Shanghai Hubang
Medical Appliance Co Ltd, China**

**Fang Lizhong
Shanghai Hubang Medical Appliance Co Ltd, Shanghai, China**

Please allow us to express our pleasure in being able to participate in the conference together with Mr. Chen Guang from China Disabled People's Federation. We are pleased to have this opportunity to discuss and share our related experience on wheelchair issues.

The Shanghai Hubang Medical Appliances Co Ltd specializes in manufacturing wheelchairs. It has taken four years for us to be the market leader of the wheelchair industry in China. Now we can produce more than 100 designs of wheelchairs suitable for China, Japan, Europe, Middle East and South Eastern Asia markets. Shanghai Hubang can manufacture a full range of steel and aluminium manual and electric wheelchairs. In the year of 2006, our production capacity and sales will reach 180,000 wheelchairs.

In China, we have set up a sound distribution path and service network nationwide. At the same time we are positively involved in the charity donation projects with the China Disabled People's Federation, China Charity Foundation, various Regional Disabled People's Federations and other charity organizations and individuals. We also export our products worldwide, and actively cooperate with the international organizations, for example, the Wheelchair Foundation from the USA.

Our aim is to be a warm-hearted Hubang staff, to manufacture high-level wheelchairs, and to be the market leader in China. In order to fulfil these three targets, the following activities are undertaken:

- Team construction and inner training:
We construct different teams. Firstly, the management team which is required to understand and implement the enterprise's culture through every part of the organisation; secondly, the inner team including research & development (R&D), production and quality departments; and thirdly, the sales and distribution teams which are given individual training in the different aspects of their responsibilities;
- Emphasis on R&D and the product and die processing centre development:
We employ talented engineers from the wheelchair industry into our R&D department, requiring them to develop new designs and components from time to time. Our product and die processing centre is the only one amongst the domestic manufacturers which is equipped with a full range of advanced computer operated machines; it greatly enhances the product development and modifying existing products.
- High capacity of self-manufacture of components:
Apart from standard parts, raw materials and some surface treatment of the wheelchair, most of the components are developed and manufactured by Shanghai Hubang itself. That is because the technical level of wheelchair and its parts in China are still at a low stage and the parts supply is limited.
- Production technology enhancement and cost control:
We participate annually in Medica in Düsseldorf, Germany and the Japan Medical Show, so we have wide connections with the major European manufacturers and we set up a partnership with an organisation in Japan, so we are aware of the differences worldwide. Improvement in production technology and facilities is the only way to enhance the efficiency of production.

Shanghai Hubang uses widely the plastic engineering parts in our wheelchairs which our domestic competitors cannot do at present, and adopt advanced technology. We

pay much attention on quality control; and reduce the cost to the minimum so the total cost is at the correct level.

- Quality control and after-sales service:

Quality is our company's life; every step in the procedure of design, material purchasing and production, even the transportation is highly controlled. Staff are responsible for the loss due to their disoperation.

We employ an after-sales service person in our main distributors all over our country, and have established sales officers in Beijing, Shanghai and Guangzhou who are responsible for the immediate service and repair in those regions.

Last but not the least, we hope to learn and share more experience and other issues related with wheelchair aspects in the coming days. Herewith, we welcome you to visit our company if have the opportunity to visit Shanghai, China.

Production: Experiences of strength testing and field trials

Stefan Constantinescu
Motivation UK, Canada

The importance of a wheelchair

A suitable wheelchair can drastically change a disabled person's life by giving them:

- improved physical functionality – making the person more mobile therefore giving more opportunity to access secondary services
- greater independence – economic and social independence
- increased confidence – for better social integration
- dignity and confidence to access their other rights.

Despite the amounts of money involved, the desires and needs of wheelchair users are often forgotten in the supply process.

If a wheelchair does not meet respected standards:

- the wheelchair manufacturer loses clients by selling unreliable products
- the funders do not get good value for their money promoting bad quality wheelchairs and putting their reputation at stake
- the wheelchair users might lose their only opportunity to achieve independence.

There are many types of wheelchairs available in the mobility products market addressing different needs according to:

- type of disability – spinal injury, polio, cerebral palsy, etc
- wheelchair user activities – depending on the lifestyle of the wheelchair user
- terrain – depending on the environment where the wheelchair is intended to be used
- locally available materials and technology – for ease of production and maintenance
- locally available wheelchair service – follow-up services including assessment and fitting
- financial considerations – the wheelchair has to be affordable
- other cultural factors.

A wheelchair meets its requirements if:

- it is strong enough to withstand the forces resulting from the interaction with the user and the environment
- it is designed and built according to the conditions imposed by the environment and user groups.

In order to evaluate a wheelchair following the two different criteria mentioned above this has to go through a series of specifically designed wheelchair strength and stability tests followed by field trials.

There are two major categories of wheelchair manufacturers according to the wheelchair production numbers:

- Large scale manufacturers
- Small and medium scale manufacturers.

Large scale wheelchair manufacturers: standard wheelchair testing

Large scale wheelchair manufacturers have the capability to:

- build their own testing facilities – usually built through their research and development initiatives and therefore invest considerable capital in testing facilities
- test their wheelchairs in private research facilities or governmental testing laboratories.



The tests are provided directly by the ISO, ANSI/RESNA and other relevant wheelchair standards that have been developed by an international group of experts over the past years.

Small and medium scale manufacturers: alternative testing solutions

The small and medium scale wheelchair manufacturers usually do not have the capital required to:

- pay the testing fee
- purchase and maintain some of the equipment required for ISO or ANSI/RESNA testing.

Wheelchair designers together with wheelchair users have developed a series of simplified strength tests over the years to provide the small and medium scale wheelchair manufacturers with low-cost but effective wheelchair testing. These tests have been developed to assist wheelchair manufacturers to test wheelchairs in their own workshops.



Some small and medium scale wheelchair manufacturers have been using these tests for several years and have found that if their wheelchairs pass these tests, then there will be a number of benefits. For the wheelchair manufacturer, the benefits of wheelchair testing include:

- being able to promote locally produced wheelchairs which reach an acceptable standard
- less wheelchairs are returned to the workshop because of faults
- better quality will result in more clients and higher sales
- their products become the benchmark which everything is measured against and they automatically get competitive advantage in the market
- promote small and medium business. Most of these businesses are run either by local NGOs or Disabled People Organisations.

The wheelchair user benefits when a wheelchair is properly tested for strength by having:

- the assurance of purchasing a reliable product
- less financial implications due to extensive product maintenance
- greater opportunity to achieve mobility
- greater opportunity to achieve independence
- higher quality of life.

Passing the alternative wheelchair tests will not necessarily mean that the wheelchairs being manufactured are of good design, therefore the tests should be used in conjunction with other information contained in the ISO, ANSI/RESNA and other relevant wheelchair standards for:

- brake effectiveness
- overall dimensions
- weight
- turning space, etc.

The tests cover as much as possible, everyday types of wheelchair use and misuse.

All the tests are static, because

- the overall testing equipment cost is low
- it is easier to duplicate the tests at another location.

As a result of performing the strength tests wheelchairs that suffer catastrophic failure can be redesigned to be able to be used under reasonably foreseeable conditions.



Example of wheelchair design that was tested and failed the strength tests



The upgraded design that passed all the strength tests

Field trials

The wheelchairs are submitted to field trials *after* they have passed all the strength and stability tests.

The wheelchair design specifications must identify and address:

- the clinical needs of the wheelchair user
- the type of environment where the wheelchair will be used

- the available materials and technology
- the cost target.

The differences in performance specification between different environments may only relate to specific components of the wheelchair, therefore design changes will need to concentrate on those components.

Wheelchairs used outdoors in low income countries are usually subjected to greater wear and tear than wheelchairs designed for use in high income countries, due to rougher urban and rural roads, sidewalks, pathways and higher curbs.

The design of the wheelchair has to take into consideration specific needs of different disabilities and user groups:

- work and home environment (with reference to turning spaces, work heights, terrain to be covered)
- distance to be covered in wheelchair, e.g. to get to work
- ability to get in and out of wheelchair – what transfer technique will be used?
- is the person's disability progressive?
- how will the wheelchair be transported?



In order to find out whether a wheelchair design meets its requirements this is submitted to field trials. As part of the field trial process wheelchair users:

- receive prototypes of the new products
- trial them for a period of time that covers most of their routine activities
- provide useful feedback to the wheelchair designers and manufacturers.

Field trials protocol

The field trials follow a protocol to ensure their effectiveness.

Several forms of data collection are used during the trials:

- **Lifestyle questionnaire**
Initial background information about the person's injury, social situation and general lifestyle is gathered during an initial interview using a lifestyle questionnaire. The lifestyle questionnaire is also designed as a measuring tool which can be used again at a later date, once users have received a new wheelchair, to look at the impact it has on their quality of life.
- **Performance questionnaire/evaluation summary**
At the end of each trial period the wheelchair user fills in a performance questionnaire as an evaluation of the wheelchair they had been trialling. The questions are then scored in order to provide an objective measuring tool for each wheelchair overall, as well as for individual features that could then be compared between different wheelchairs.

- Home visit
During each trial period the wheelchair users are visited at home and asked questions on what they thought of the wheelchair e.g. indoor use, outdoor use, ease of transfers, use of transport and any general comments, etc.
- Diary
The wheelchair users are asked to keep a daily diary of what they do during each day and to record any observations they had about the wheelchair. This is designed to help them remember their evaluations during the trial. It also gives an idea of the extent to which people are using the wheelchairs, with some users being much more active than others.
- Photographs
Each wheelchair user is photographed in the trial wheelchair from different angles as a comparative record. Any problems that are noted during the trial relating to the design or performance of the wheelchairs are also photographed, if possible.



At the end of the field trials the results are compiled together and a list of necessary design changes is prepared.

Conclusion

Wheeled mobility products that are intended for use by persons with disabilities should be appropriate for the environment in which they will be used and the specific people who will use them. Designers and evaluators should consider all the necessary appropriate strength and suitability features of quality products.

Relevant ISO and ANSI/RESNA standards to be used in conjunction with the small and medium wheelchair manufacturers alternative testing

ISO 7176- Wheelchairs

Part 1: Determination of static stability

Part 3: Determination of efficiency of brakes

Part 5: Determination of overall dimensions, mass and turning space

Part 7: Measurement of seating and wheel dimensions

Part 8: Requirements and test methods for static, impact and fatigue strengths

Part 11: Test dummies

Part 13: Determination of coefficient of friction of test surfaces

Part 22: Set-up procedures

ISO contact details:
ISO Central Secretariat
International Organization for Standardization (ISO)
1, rue de Varembe, Case postale 56
CH-1211 Geneva 20, Switzerland
Website: www.iso.ch
Email: iso@iso.ch

ANSI/RESNA Wheelchairs Standards Volume 1: requirements and test methods for wheelchairs (including scooters)

Section 0: Nomenclature, terms, and definitions
Section 1: Determination of static stability
Section 5: Determination of overall dimensions, mass, and turning space
Section 7: Determination of seating and wheel dimensions
Section 8: Static, impact, and fatigue strengths
Section 11: Test dummies
Section 13: Determination of coefficient of friction of test surfaces
Section 93: Maximum overall dimensions

RESNA contact details
RESNA
Rehabilitation Engineering Society of North America
1700 N. Moore St, Suite 1540, Arlington, VA 22209-1903, USA
Website: www.resna.org
Email: info@resna.org

Plenary discussion: Production

Chairman: Claude Tardif
Rapporteur: Sarah Sheldon

In response to questions it was noted that Hubang Shanghai Medical Appliances intend to explore markets in China and neighbouring countries. It only produces products within partnerships. It currently exports to America. It uses both metric and imperial parts, but mostly imperial for exported products.

The Wheelchair Foundation clarified that they do not currently import Hubang wheelchairs into the USA as they are waiting for FBA approval. They do use Hubang wheelchairs in foreign countries.

Hubang stated that they would need to produce 1000 wheelchairs of a certain design to justify the cost of retooling. It was suggested that organisations should work together to develop an acceptable wheelchair design given this relatively low figure, however it was also pointed out that this figure could vary and would be dependent on a number of factors. Hubang were congratulated for the number of wheelchairs they are producing and asked how they obtained their start up capital. This was gathered through shareholders.

The Wheelchair Foundation was asked if they would they take up offer of support from people within the conference to deliver a wheelchair that is more acceptable. It responded that it would be open to input. It operated within cost restraints and does not have an unlimited budget for development. It has explored most existing wheelchair designs during the last six years, and is open to input for whatever potential there is. A comment was made that it would be beneficial to formalise any collaboration during the week as these initiatives can be more difficult to follow-up remotely.

It was suggested that the conference group agree a common nomenclature regarding local-regional-global or small-medium-large scale production.

It was suggested that a study was made to compare wheelchair provision by wheelchair technologists with that by other medical personnel.

Amicale Marocaine des Handicapes (AMH) have received 1800 Wheelchair Foundation wheelchairs which have been distributed all over the country in mountains, desert and countryside. This has been done over the past 1.5 years and the wheelchair has been evaluated, there are currently no big problems with the wheelchair from their perspective.

Students at TATCOT study strength tests and field trials as part of their curriculum and should be able to utilise this knowledge after they graduate. Motivation is carrying out graduate follow-up and is assessing how well they are doing this.

All stakeholders have a part to play in promoting professionalisation in the field and advocating that governments recognise wheelchair technology as a profession. It was noted that events such as stakeholder conferences can help in understanding of the profession and help promote it. It was also suggested that Wheelchair Technologists can register with rehabilitation councils in their respective countries.

A comment was made regarding the importance of responding to needs of users. In Kenya the highest need is for hand tricycles not for standard wheelchairs, and the need for supportive seating is also growing. Some 80% of the Association for the Physically Disabled of Kenya's (APDK) production is focused on tricycles and supportive seating, but donors tend to focus on standard wheelchairs.

It was also recognised that much design work in wheelchair is geared towards high level functioning paraplegics and not towards more specialised needs such as quadriplegics, cerebral or hemiplegics.

It was suggested a wheelchair with the functions of a tricycle would be valuable.

Supply and distribution: Cost sharing, supply, roles of the stakeholders, distribution

Kylie Mines
Motivation UK, Bristol, UK

Approaches to wheelchair provision

The following paper provides an overview of the way in which wheelchairs are supplied in less resourced settings, including:

- Production: where wheelchairs come from?
- Type of wheelchair
- Service provision: how wheelchair users access wheelchairs?
- Local wheelchair services
- Financing: how wheelchair provision is financed?
- Roles of the stakeholders in a system of wheelchair provision which includes more appropriate products supplied through wheelchair services is outlined.

Source: where do the wheelchairs come from?

National production – including small or larger workshops producing wheelchairs for national supply. There are many small workshops across the developing world, producing wheelchairs from locally available materials, using low technology manufacturing techniques. These are often owned and managed by local NGOs. In some countries there are also production facilities producing larger numbers of wheelchairs for national distribution.

Imported wheelchairs – including new and used wheelchairs. New wheelchairs are predominantly produced in large manufacturing units. Some new wheelchairs are specifically designed and produced for distribution in developing countries – however this is not always the case. Used wheelchairs are predominantly orthopaedic style wheelchairs which have been re-furbished. Most imported wheelchairs are shipped in bulk, by the container load.

Issues surrounding the source of wheelchairs:

- Economic development – local production can support the economic development of an area through the purchase of local materials, and employment of local staff.
- The understanding of the supplier of the needs of wheelchair users, and ability to respond to the needs of users. Where suppliers are disconnected from users, it is less likely that they are able to understand the context in which those who use their wheelchairs live, and they are less likely to be able to receive feedback regarding the appropriateness of the product.

Wheelchair selection

Strength and durability: Strength and durability are of critical importance for wheelchair users living in the environments typically seen in many less resourced settings. Rough roads, lack of pavements, sandy/gravelly/muddy terrain all require wheelchairs to be strong and hard wearing. Many wheelchairs supplied in less resourced settings do not have sufficient strength and durability for the context.

Performance: This refers to the specific features of the wheelchair and how they match the needs of the wheelchair user. A pressure relief cushion is an example of a performance feature; a wheelchair with a pressure relief cushion is designed to provide pressure relief. Orthopaedic style wheelchairs, one of the most common wheelchair types to be found in less resourced settings, are designed for short term, indoor use. They are un-suitable for outdoor use, difficult to self-propel, provide minimal postural support and no pressure relief. These performance features do not match the needs of the majority of the wheelchair users in less resourced settings.

Range: Due to the diversity in the wheelchair user population, there are many different types of wheelchairs. This is important, as *no single wheelchair can meet the needs of all wheelchair users*. However, in most less resourced settings, there is very little choice of

wheelchair product for wheelchair users. Where wheelchairs have been sourced in bulk, they are usually of one type. Where wheelchairs are produced locally, there is often only one or two designs being produced.

Repairs: For wheelchair users, fast and in-expensive repair of their wheelchair is extremely important. Wheelchairs selected for supply in less resourced settings need to allow for either local repair, or local availability of low-cost replacement parts. The difficulty in either repairing, or accessing replacement parts is a major problem with the supply of wheelchairs originally designed for use in developed countries.

Cost: Wheelchairs need to be affordable. However, it is also important to recognise that cost cannot be the only factor. An in-expensive wheelchair which breaks down, or does not meet the physical or lifestyle needs of a user is not effective. Cost factors should also consider the cost of transporting and storing wheelchairs; and the service element of wheelchair provision which is discussed in the following section.

Whose decision?: In most current programmes of wheelchair provision, the decision regarding which wheelchairs are selected for supply is predominantly in the hands of those delivering the wheelchairs, not those who will use them.

Service provision: how do wheelchair users access wheelchairs?

The way a wheelchair user receives a wheelchair has a major impact on whether the wheelchair improves the user's quality of life. In the industrialised world, most wheelchair users have access to a wheelchair service, which assists them in selecting and fitting the most appropriate wheelchair to meet their needs.

However, wheelchair services in less resourced settings are rare. This is due to many factors, including scarce resources, a lack of appropriate products and a lack of training for health and rehabilitation staff in wheelchair provision. The result is that many wheelchair users in less resourced settings receive a wheelchair without assessment, prescription or fitting.

Methods of service provision in less resourced settings can be grouped into two main categories; distribution and service approaches.

Distribution approaches

Distribution approaches focus on delivery of wheelchair products, without service provision. Examples of this approach include:

- *Private purchase through shops:* Wheelchair users with sufficient funds, in some countries, are able to purchase imported wheelchairs from shops selling medical equipment and aids, for example local pharmacists. In the majority of cases the wheelchairs available through such outlets are of an orthopaedic style, suitable for short term, indoor use.
- *'Store room distribution':* Wheelchairs (often donated wheelchairs) are given out to wheelchair users as they need them, from store rooms in, for example, hospitals, social welfare or NGO offices.
- *Donation ceremonies:* Wheelchairs are handed out to wheelchair users in a donation ceremony.

Characteristics of distribution methods include:

- Fast method of distribution at relatively low financial cost
- Personnel handing out wheelchairs are untrained, and do not have the skills required to select the most appropriate wheelchair for the user.
- No assessment or prescription. In many instances the user may not be present.
- No user instruction, no follow-up
- Usually no maintenance or repair support
- Often recipients are selected randomly without a full assessment of the needs of the overall wheelchair user population in the area.
- There is a high chance the wheelchair will not meet the user's needs

- There is a high chance of physical harm to the wheelchair user caused by the wheelchair not fitting correctly, or being in-appropriate for the wheelchair user's physical needs.

Service approaches

Service approaches place a greater emphasis on ensuring that the wheelchair and wheelchair user are appropriately matched. Three examples of service approaches and the characteristics of each include:

Expatriate staff provide assessment and fitting: This usually involves volunteer physiotherapy or occupational therapy staff making short duration trips to support the delivery of imported, donated wheelchairs. During the visit, the skilled volunteers work hard to match users with the best wheelchair from those available. Depending on the materials and facilities available, individual modifications may be made to gain the best fit for the wheelchair user. Challenges with this type of approach include:

- Visiting staff may have limited knowledge of the local context. This may affect the decisions they make during assessment, prescription and the fabrication of modifications.
- Education of wheelchair users during such visits is limited by time, and language issues. After the visit, there may not be anyone available to answer further questions.
- It is difficult to coordinate follow up. This is particularly an issue where modifications are being made; this type of intervention requires follow-up, which may not be feasible given funding constraints and the availability of volunteers.
- Maintenance and repair may be difficult for the users once the visiting staff have left. This is particularly an issue when wheelchairs are imported.

National wheelchair workshops: Small wheelchair workshops often provide an assessment and prescription service, in the absence of other options. Workshop staff may have knowledge and training in assessment and prescription, and have the capacity to provide individual modifications. Direct access to the workshop provides a greater chance that wheelchair users will have a choice in the wheelchair they receive. Wheelchair users are also able to return to the workshop for support with maintenance and repairs. However, where the workshops primary focus is producing wheelchairs, this can present challenges for the workshop, including:

- Time spent in assessment, prescription, follow up, maintenance and repairs may not be funded or accounted for
- The environment of a workshop is not appropriate for a full assessment
- Workshop staff may be unable to spend time on wheelchair user instruction

Local wheelchair services with trained local staff: There are few local wheelchair services, with trained local staff, that are able to offer a full wheelchair service including assessment and prescription, individual modifications, follow-up, maintenance and repairs. Through a wheelchair service, it is more likely that wheelchair users will have a greater say regarding which wheelchair they receive. Wheelchair services are able to coordinate waiting lists, ensuring that the provision of wheelchairs is more equitable. Wheelchair services are able to work closely with other rehabilitation services and can build up referral networks over time. This approach requires trained staff, facilities and sustained funding.

Local wheelchair services

Wheelchair services provide a link between wheelchair users and producers. Wheelchair services can provide the framework to assess individual wheelchair user needs, provide an appropriate wheelchair, instruct and educate wheelchair users and provide ongoing support and referral to other services where appropriate. In addition, wheelchair service providers can also have a role in:

- Raising the standards of wheelchairs within their country/region,
- Educating referral networks and raising the awareness of suppliers and funding agencies regarding the role and importance of wheelchair services,
- Developing financial sustainability solutions for the ongoing provision of mobility equipment through wheelchair services,
- Providing and/or supporting the training of wheelchair service staff.

The provision of wheelchair services in less resourced settings requires careful planning and management of resources. Some strategies which can be employed to initiate wheelchair provision, or further develop services for wheelchair provision include:

Utilise existing staff: With additional training, many health and rehabilitation workers would be able to take on the roles required for basic wheelchair service provision. For example, community health care workers, Community Based Rehabilitation (CBR) workers, nurses, physiotherapists, occupational therapists, orthotists and prosthetists, could be trained to fulfil the clinical role in wheelchair services. Likewise, with additional training, skilled craftspeople, mechanics and orthotics/prosthetics technicians could fulfil the technical role in wheelchair services.

Integrate wheelchair services with existing health or rehabilitation services: A wheelchair service centre or department can be established within existing rehabilitation services. Such services are already likely to have wheelchair users accessing the service for health or rehabilitation needs. They would therefore already have much of the infrastructure required to establish a wheelchair service. Examples of rehabilitation services well suited to the integration of a wheelchair service include prosthetics and orthotics services and spinal injuries rehabilitation units.

Meet the needs of wheelchair users at community level where possible: Some aspects of wheelchair provision can be carried out in the community, through a network of community based organisations (for example CBR programmes, community health programmes) supported by a local wheelchair service centre.

The benefit of wheelchair service provision for wheelchair users:

- Professional assistance in wheelchair selection and fitting,
- More appropriate wheelchair and fit,
- Opportunity for instruction in wheelchair use (for example how to handle the wheelchair, how to transfer in and out of it, how to use the cushion correctly, skills in wheelchair mobility and wheelchair maintenance),
- Follow up available for problems, maintenance and repair,
- Far greater chance the wheelchair will result in improved quality of life for the wheelchair user,
- Link to producer, opportunity for wheelchair user to provide feedback to suppliers.

The benefit for suppliers:

- Greater chance of the wheelchair users being satisfied with the product,
- Possible to gain coordinated feedback from wheelchair users about the product.

Financing: how is wheelchair provision paid for?

When considering how wheelchair provision is paid for, it is important to consider the total costs involved. The cost of service provision as well as the cost of the product must be accounted for:

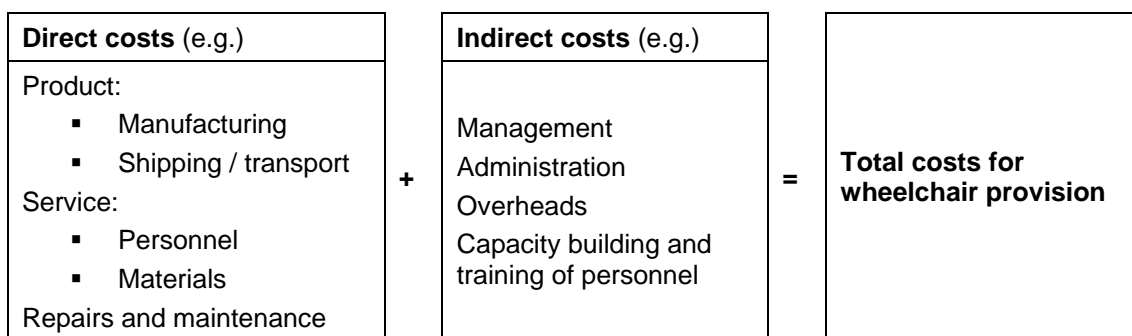

Most wheelchair users in less resourced settings cannot afford to pay for a wheelchair. Financing assistance is therefore necessary to enable wheelchair users to access a wheelchair through a service. There are a range of approaches to wheelchair funding, including:

Government funding: The most sustainable funding source is usually Government funding, where the Government has a commitment to wheelchair provision. There are less resourced countries where the Government has an allocated budget for the purchase of wheelchairs.

Donor funding: In many contexts, wheelchair provision is funded by donor agencies. Donor funding can be provided in a number of ways. In some instances, funding focuses on the purchase of wheelchairs, with less consideration for service provision. 'Donation ceremonies', where wheelchair users are given a wheelchair without assessment or prescription, are an example of this approach. In other instances, donor funding can be used to support the initiation of a wheelchair service. These funds may be utilised for initial capital/start-up costs as well as for ongoing support of the service and purchase of wheelchairs. Due to its usually short-term nature, donor funding should be complemented with advocacy for government and other more sustainable funding solutions.

Wheelchair funds, managed by committee: In some contexts, 'wheelchair funds' have been established to subsidise the cost of wheelchairs for individual wheelchair users. Wheelchair funds exist to source funding and equitably manage donations secured for wheelchair provision. Wheelchair users apply to the wheelchair fund committee for full or partial contribution to the cost of a wheelchair. Such funds are often means tested to determine how much financial assistance should be given. Government funding may also be channelled through a wheelchair fund. Ideally wheelchair fund committees comprise a cross-section of individuals who have an interest in sustainable wheelchair provision, such as, but not limited to, wheelchair users, DPO representatives, clinicians and technicians, government representatives and local dignitaries.

Contributions from wheelchair users: User contributions are an element of some financing systems, particularly where Government funding is not provided for wheelchair purchases. User contributions have been shown to promote pride of ownership and greater care for the wheelchair. User contributions also stimulate demand for appropriate quality products and services. Contribution programmes are usually run in conjunction with an individual means test process, to ensure that wheelchair users contribute no more and no less than they can realistically afford.

A credit scheme is an option that allows wheelchair users to borrow funds to purchase a wheelchair and to repay those funds over a period of time. Another option is an employment scheme that links wheelchair provision with the opportunity for the user to get a job or small business start-up funding and to repay the cost of their wheelchair over time.

Income generation: Some wheelchair provision programmes are subsidised through complementary income generation projects. This is particularly relevant where wheelchairs are being produced through a local workshop. The workshop may produce and sell lower cost

mobility products (for example canes, crutches, walkers, toilet and shower chairs), using the revenue gained to support the wheelchair production.

Roles of the stakeholders

There are many stakeholders involved in the supply and provision of wheelchairs. The following looks at the different roles of stakeholders in a system of wheelchair provision which includes more appropriate products supplied through wheelchair services.

Policy planners and implementers:

- Development of wheelchair service provision policy in consultation with stakeholders including the National Government where they are not already the lead implementer / policy maker,
- Supporting guidelines for wheelchair products, service provision and training,
- Ensuring wheelchair provision is equitable and accessible,
- Developing sustainable funding policies for wheelchair provision.

Manufacturers and suppliers:

- Manufacture the most appropriate product for the intended wheelchair users,
- Ensure their products are appropriate for the environment in which they will be used (considering strength, durability, performance, range and repairs),
- Actively seek feedback from wheelchair users, for example through user trials,
- Recognise the importance of wheelchair service provision and provide wheelchairs through wheelchair services.

International Non-Government Organisations:

- Meet the immediate needs of wheelchair users where local wheelchair provision is absent,
- Ensure activities are part of a broader long term strategy acknowledged and supported by the relevant duty bearers, e.g. Government,
- Plan wheelchair provision in collaboration with Governments and other stakeholders
- Build capacity and facilitate links between different stakeholders; wheelchair users, DPOs, wheelchair services and Governments or duty bearers,
- Implement wheelchair services include best practices for replication by Government and other INGOs,
- Provision of training and technical expertise where none is available locally.

Disabled People's Organisations:

- Define wheelchair user's needs and barriers to equal participation and opportunities
- Raise awareness of the need for effective wheelchair service provision and financing
- Consult with policy planners and implementers in the development stage of initiating wheelchair services
- Identify people who need wheelchairs and refer them to wheelchair services
- Participate in evaluation of wheelchair services
- Advocate for wheelchair services which comply with agreed guidelines and against inappropriate wheelchair provision
- Support wheelchair users in the community by providing peer support and training.

Wheelchair users:

- Participate in the planning, implementation, management and evaluation of wheelchair provision,
- Participate in wheelchair design development including wheelchair product trials,
- Work as employees within wheelchair services.

Supply and distribution: Supply and distribution systems: local community: Disacare, Zambia

**David Mukwasa
Disacare, Lusaka, Zambia**

Disacare Wheelchair Centre Trust is a self-help disability NGO that is predominantly involved in the production and repair of wheelchairs and other mobility aids, and providing employment to persons with disability. The organisation was formed by persons with physical disabilities in 1991, and has over the years worked with a number of international organisations involved in wheelchair technology. As a result of this work, Disacare is now producing a Whirlwind wheelchair design (the Kavuluvulu), hand tricycles, and bicycle ambulances which have been designed specifically to cope with the rough terrain of Zambia.

Disacare is now a recognized Regional Resource Training Centre in Africa by the Pan African Wheelchair Builders Association (PAWBA) and is currently pursuing registration with the Technical Education, Vocation and Entrepreneurship Training Authority (TEVETA).

Disacare's vision is:

Economically and socially empowered mobile persons with physical disabilities.

Its mission statement is:

Disacare Wheelchair Centre Trust provides training in appropriate wheelchair technology for Sub Sahara Region and manufactures durable mobility aids for persons with physical disabilities in Zambia.

The organisation states its values as independency, accountability, transparency, honesty, adaptability, efficiency and self-sustenance. Disacare has four main objectives:

1. To promote the inclusion of the persons with disabilities in social and economic independence.
2. To provide job opportunities and basic skills to persons with disabilities and youth in general in Lusaka.
3. To manufacture, alter and repair of orthopaedic apparatus, appliances and accessories, and technical mobility aids affordably.
4. To promote partnerships with the disabled community and other stakeholders in the provision of recreation facilities.

Disacare believes its secret of success lies in community Support and works together with its trustees, government, corporates, churches and embassies.

The Zambian Government does not give much support in the distribution of local wheelchairs. However, in incidences where a government minister would like to be seen to make a donation they would buy from Disacare. Otherwise, the Government relies on donated wheelchairs. Very few businesses purchase local wheelchairs, however in the past two years some church organisations were major buyers of Disacare wheelchairs.

Embassies such as the British High Commission and the Finnish Embassy no longer are involved in purchasing wheelchairs directly although they are willing to consider proposals for the purchase of wheelchairs for donation to other organisations.

There are very few users who can afford to buy a wheelchair, so they rely on support from well wishers. Those who can afford usually are in good employment and would prefer a fancy looking hi-tech wheelchair than a locally made model.

With the formation of a Wheelchair Financing Committee it is hoped that Disacare will be able to mobilize local resources. During a visit by Motivation, visits were made to government ministries, embassies and businesses and yielded positive results. The Wheelchair Financing

Committee must be strengthened for it to make headway in generating funds. International partnerships should be established and strengthened. Distribution of wheelchairs should be related to other programmes such as rehabilitation and poverty eradication.

**Supply and distribution:
Supply and distribution systems: camp approach: ALIMCO,
India**

**Atul Dubey
ALIMCO, Bangalore, India**

The Artificial Limbs Manufacturing Corporation of India (ALIMCO), a central Public Sector Undertaking under the Ministry of Social Justice & Empowerment, Government of India has been engaged in the production and supply of assistive devices including different types of wheelchairs to the physically challenged for more than thirty years. The Corporation has a capacity of manufacturing more than 40,000 wheelchairs (five types) in its four production units along with an elaborate supply network in India. The Corporation is equipped with 'state of the art' mass manufacturing facilities along with suitable test facilities for manufacture of ISI marked Assistive Devices.

For the last few years, the Corporation has embarked on a "Camp Approach" for providing Assistive Devices to a fairly large number of physically handicapped in various categories within reasonable distance from their living place under the government sponsored ADIP scheme in different forms. These camps are normally conducted in collaboration with the State government/ district officials/Ministry of HRD/NGOs in different parts of the country including remote areas and difficult terrains.

The Camp Approach primarily consists of initially holding an 'Assessment Camp' in which the beneficiaries are screened for requirement of Assistive Devices by a team of medical and rehabilitation professionals. The team completes all the desired documentation work inclusive of prescription of the appropriate Assistive Devices. The identified beneficiaries are thereafter provided with the prescribed Aids & Appliances in the Distribution/follow-up camp. The Distribution Camp is normally held within a period of 3-6 weeks after the assessment camp. The beneficiaries are also given a short "on the spot training" on the use of the Assistive Devices in the Distribution Camp. In some special cases the Corporation also holds a combined 'Identification cum Distribution camp' for the benefit of a large number of beneficiaries.

ALIMCO also provides spare parts for assistive devices through its supply network while repair facilities are available in its central production unit and auxiliary production centres, strategically located in India.

Through the Camp Approach the Corporation has been able to provide assistive devices to approximately 117,000 beneficiaries in 938 camps, and wheelchairs have been provided to more than 20,800 beneficiaries in the year 2005-06.

Supply and distribution: Supply and distribution systems: large scale distribution: Wheelchair Foundation, USA

**Joel Hodge
Wheelchair Foundation, USA**

Sponsorship

All wheelchairs must be funded somehow:

- Private individuals
- Corporate donors
- Grants
- Other organisations (NGOs, Foundations, etc)
- Internally through WCF fundraisers

Consultation on destination

- Donors are consulted about target destination countries and distribution partners
- Prequalification of donor suggested distribution partners and recommendations
- Management of donor expectations

Selection of distribution partner

Initial contact and capacity:

- Verify that they have access to the disabled population
- References and history
- Identification of recipients
- Qualification and approval of recipient organisations (hospitals, clinics, schools, etc)

Or, selection of a distribution partner from WCF database of over 970 existing partners

Standard NGO contract and WCF's requirements:

- contact information
- shipping destination
- duty and VAT waivers
- documentation requirements
- chair sizes
- warehousing
- distribution requirements

Appropriate wheelchair clause:

Important Notice: It is critical that the Consignee and distributing organisation(s) are aware that the standard manual wheelchairs provided by Wheelchair Foundation are not intended for use by individuals affected by some neuromuscular diseases, such as Cerebral Palsy, severe cases of Polio, Multiple Sclerosis, or other conditions that effect skeletal structure (extreme deformation of limbs or torso, etc.) or body motor control (spastic movement, seizures, convulsions, tremors, etc.). Individuals with such conditions may require specific specialized wheelchairs, and additional appliances not provided by Wheelchair Foundation to assure proper seating and support. Placing such individuals in standard manual wheelchairs can result in severe harm to the individual recipient and should be avoided. If the consignee or distributing organisation is unable to assess whether a standard manual wheelchair is appropriate for any particular individual recipient it is recommended by Wheelchair Foundation that the consignee or distributing organisation consult with a physician or specialist to determine whether or not a standard manual wheelchair will be appropriate for the intended individual recipient.

Other considerations:

- Contact information
- Shipping destination

- Duty and VAT waiver
- Documentation requirements
- Chair size recommendations
- Warehousing
- Distribution requirements

Contract:

- Contract out
- Signed and returned
- Questions and concerns

Purchase order process:

- Proposed purchase order submission
- Purchase order approval
- Submission for manufacture

Shipping dates and acronyms:

- FAD: Factory availability date
- ETD: Estimated time of departure, which triggers:
 - Booking
 - Documentation processing and shipping
 - Placards and camera shipping
- ETA: Estimated time of arrival

Arrival at port and clearance:

- Agents
- Consignee interaction and responsibilities:
 - Port charges
 - Local customs charges
 - Demurrage
- Inland Transportation

Warehousing:

- Container unloading
- Container return:
 - Container purchase (necessary in active conflict areas)
 - Other exceptions

Distribution:

- Planning (location and facilities, who to invite, timing, etc)
- Execution:
 - Large single or multi-day distribution:
 - Recipient transportation and arrival
 - Recipient hospitality at event
 - Seating and adjustment
 - Photos
 - Egress
 - Small ceremonial distribution
 - Multi-week/month distribution
 - Rural reach and penetration
 - Time line:
 - Absolute minimum time to deliver and distribute ~2 days
 - Average 90 to 120 days
 - Extreme 18 to 24 months
- Less than three containers lost or unaccounted for in over six years and more than 2000 shipments to 144 countries

Follow-up:

- Return of photos
- Verification of delivery

- NGO feedback
- User feedback
- Donor reporting

Repeat the whole process

Supply and distribution: Supply and distribution systems: IBR/CBR approach, Interlife, Bangladesh

Johan Borg
WHO, Geneva, Switzerland

Abstract

The Assistive Device Web (ADWeb) is an approach to delivering assistive technology services. The ADWeb concept utilises existing government, non-government and private organisational structures and resources. The service delivery system is made up of seven types of service providers. After receiving training, an organisation assumes the responsibility of a particular service provider according to its capacity. The ADWeb concept was developed by a network of suppliers of assistive technology in Bangladesh. After consultation with different stakeholders the concept was finalised. The service delivery system is currently being implemented by providers of CBR services, suppliers of assistive devices, local craftsmen and health centres, as well as other local and national resources.

Content

The purpose of this paper is to describe the Assistive Device Web (ADWeb), a network approach to delivering assistive technology in developing countries. The paper is divided into the following parts:

- Concern: the rationale behind ADWeb
- Context: the process of and factors considered while developing ADWeb
- Concept: the structure of ADWeb and its activities
- Contest: how quality standards and users can influence ADWeb and its partners
- Concert: a brief account of the first field experiences of ADWeb
- Concord: ADWeb in relation to the themes of a WHO workshop on assistive technology for developing countries

Concern

In many countries, including Bangladesh, most people with disabilities do not have opportunities to exercise fundamental human rights and freedoms. One of the reasons is that assistive devices and related services are not accessible to those who need them, especially in rural areas. An assistive device might be inaccessible to a potential user due to lack of access to:

- Information: the potential user, people in his or her surrounding, and related medical or rehabilitation personnel do not know that an assistive device might be helpful or where to get an appropriate device.
- Expertise: the number of people with adequate competence and skill levels is not sufficient.
- Products: the production capacity of a particular type of device is not sufficient or the quality is not satisfactory.
- Service points: the service providers are located too far away in terms of traveling time or distance.
- Financial means: the user cannot afford the device or necessary traveling.
- Legal support: legislation on provision of assistive devices has not been adopted or is not practiced.

With economic and social progress, expanding rehabilitation therapy services, especially through different CBR strategies, and increased awareness of assistive devices, the demand for appropriate assistive devices of satisfactory quality increases.

Context

In response to the concern, a network of about 15 relatively small government, non-government and private suppliers of assistive devices in Bangladesh, called the Assistive Device Network (ADNet), formed a Service Delivery Subcommittee with a mission to develop

a service delivery system for assistive devices. The Subcommittee decided to develop a service delivery strategy that is based on existing resources. The concept, named ADWeb, was presented and further developed at a national workshop with representation of stakeholders including users, technicians, CBR workers, therapists, managers and policy makers.

Bangladesh is a densely populated country with about 80% of the total population of approximately 140 million living in rural areas. The Gross National Income was US\$360 per capita in 2002. In a ranking of 175 countries in 2003, the Human Development Index placed Bangladesh at 139th place. The culture of non-government organisations supplementing the development efforts of the Government of Bangladesh is very rich.

Existing resources that were considered at the outset of developing ADWeb, besides users of assistive devices, include government, non-government and private (a) suppliers of assistive devices, (b) implementers of CBR, (c) providers of health care, and (d) networks related to disability and health issues, including a forum of organisations acknowledged by the government as reference group on disability related issues.

Necessary activities of a service delivery system were identified. Depending on its nature and capacity, a resource can undertake certain activities within a service delivery system. To utilise the existing resources in order to facilitate access to assistive devices and related services, different types of actors were defined. Each actor is responsible for undertaking one or more of the activities.

Concept

ADWeb is a service delivery system for assistive devices that is implemented by collaborating organisations. As ADWeb is based on existing organisations, there is no need for establishing new organisational structures. However, depending on local circumstances or the stage of development of the system, a Committee that guides the service delivery system may be formed. The members of the Committee would include representatives of collaborating organisations and users.

The network of ADWeb is constituted by the collaborating organisations, which are the actors of ADWeb. With the ADWeb terminology the actors are called Nodes. A policy framework, which includes terms of reference, memorandums of understanding and node requirements, governs the responsibilities and activities of the Nodes. The names of the Nodes and their main activities are given in the table below. Typical roles different resources may play as actors within ADWeb are also indicated in the table.

Nodes (Types of actors)	Activities	Types of resources
Regional Service Node	<i>Regional/Local level:</i> coordination, arranging training, arranging camps with Product Nodes, disseminating information, user forums. <i>Product related services:</i> display, assessment, prescription, adaptation, fitting, practice, delivery, follow-up, repair, maintenance, and referral.	Suppliers of assistive devices

Service Node	<i>Local level:</i> disseminating information. <i>Product related services:</i> assessment, prescription, adaptation, fitting, practice, delivery, follow-up, repair, maintenance, and referral.	Suppliers of assistive devices Implementers of CBR
Referral Node	<i>Local level:</i> disseminating information. <i>Product related services:</i> referral (e.g. directing potential users to appropriate Product, Service or Regional Service Node after a preliminary assessment).	Implementers of CBR Providers of health care
Information Node	<i>Local level:</i> disseminating information (e.g. displaying posters with information on nearest Referral, Service or Regional Service Node, or offering handouts with basic information).	Implementers of CBR Providers of health care
Product Node	<i>National/Regional/Local level:</i> supplying products to Service and Regional Service Nodes and users, arranging camps with Regional Service Nodes, disseminating information. <i>Product related services:</i> assessment, prescription, adaptation, fitting, practice, delivery, follow-up, repair, maintenance, and referral.	Suppliers of assistive devices
User Node	<i>National/Regional/Local level:</i> testing, evaluating and proposing products and services.	Users, DPOs
Coordination Node	<i>National level:</i> planning, coordination, capacity assessment and building, developing and disseminating information, monitoring, follow-up, evaluation, user forums, advocacy and lobbying, research and development, developing standards and testing methods.	Organisation with adequate technical, administrative and networking capacity

To the users, the major difference between Regional Service Nodes, Service Nodes and Product Nodes is, that almost all types of assistive devices and related services are available at Regional Service Nodes, at least during a period of time every year, while a limited range of assistive devices and related services are available at Service Nodes, and very specific types of assistive devices, with or without related services, are available at or supplied from Product Nodes, respectively.

Existing national and regional networks can be used for collection and dissemination of information, communication with organisations, lobbying and advocacy. To promote improved quality of products and services, national networks may act as accrediting bodies of product and service standards until a national standardization institute adopts appropriate standards.

Before an organisation becomes an ADWeb Node, its capacity must be assessed and the training needs must be identified in relation to established requirements. After necessary capacity building, often arranged by the Coordination Node, the organisation starts to function as a Node.

If a single organisation does not have, or cannot develop, the required capacity to undertake activities of a particular Node, that organisation may link up with another organisation, and those two organisations can jointly assume the responsibilities. Further, an organisation without production facilities may cooperate with local artisans that are trained to make assistive devices.

Regional Service Nodes coordinate activities of Service Nodes, Referral Nodes, Information Nodes and User Nodes within a particular region of a country. When selecting a Regional Service Node, both the organisational capacity and the geographic location should be considered.

The long-term goal is to make ADWeb self-sustained. This can be done by letting the buyers of products and services delivered through ADWeb pay, or by having a long-term national or

international donor agency subsidizing the system. However, funding is initially needed for setting up ADWeb, specially the Coordination Node and the Regional Service Nodes.

All ADWeb Nodes are responsible for their own funding. Some organisations can, at least partially, cover the costs from selling products and services. Most organisations do not need to recruit any new staff to work with ADWeb. The additional skills staff gets after receiving training helps them to carry out their duties, for which the costs already are covered, in a better way. Some organisations may need to invest in tools, machines or infrastructure.

The Coordination Node plays a key role within ADWeb. The organisation responsible for the Coordination Node must ensure funding to cover the costs for all the activities. If the other Nodes have funding for staff development or other activities, the Coordination Node may charge for its services, e.g. course fees. Another possibility to sustain the Coordination Node is that the other Nodes contribute to the costs of running the Coordination Node. Especially Product Nodes may appreciate the work of the Coordination Node as their markets grow.

Contest

Users of assistive devices and services delivered through ADWeb are the ultimate judges of the system. In order to include their opinions and experiences, User Nodes are established locally, or in cooperation with DPOs, and linked to the Coordination Node and Regional Service Nodes. Service and Product Nodes are encouraged to associate themselves with user groups. Users of products obtained through ADWeb Nodes are requested to give feedback on the products and the services. ADWeb's existence is only justified as long as the needs of its users are met.

In order to improve the quality of products and services, and thereby satisfy the users, the Coordination Node will support the development of requirements on different types of assistive devices. ADWeb should only promote products that meet the requirements. The requirements may later on become national standards for assistive devices and related services.

Concert

With permission from ADNet, one of its member organisations, InterLife – Bangladesh, developed a pilot project to test the ADWeb concept in one of the six divisions of Bangladesh. Since the second half of 2003 totally 30 organisations in the selected division have received training. One of the courses is a combination of 15 days training for CBR workers on prescribing and providing basic assistive devices (the Assistive Device Facilitator course), and 5 days training of the CBR workers and wood artisans, selected by the local organisations, on how to make simple wooden assistive devices (the Assistive Device Artisan course).

The responsibilities of the Coordination Node are undertaken by InterLife – Bangladesh. Three organisations in the selected division act as Regional Service Nodes. Trained organisations and about 15 suppliers of assistive devices, mainly located in the capital Dhaka, play the roles as Service Nodes and Product Nodes, respectively. The Regional Service Nodes and Service Nodes contact local organisations that can act as Referral and Information Nodes.

To learn from the field and develop the training courses, the Coordination Node visits the field and evaluates the provision of assistive devices. For example, in April 2004, a brief evaluation of the assistive device related the work of three teams of CBR workers and wood artisans was undertaken. A total of seven users of assistive devices in rural areas were studied. The findings show that the teams had identified appropriate functional needs for six of the seven users (86%). Also for six of the seven users (86%) the respective team had selected appropriate or partially appropriate assistive devices. Five of the seven users (72%) use their assistive devices regularly. All devices were made of locally available materials and parts. For some of the devices the family had provided the material. The prices of the locally made assistive devices amounted to 10-40% of the prices of devices with similar functions sold by suppliers in Dhaka.

The results of the evaluations indicate that many of the needs can be met at local level and at low cost after relatively little training input. Wood artisans have showed a high degree of commitment and expressed satisfaction about using their skills to make assistive devices. If feasible some of them would like to focus on making assistive devices only.

Even though InterLife – Bangladesh intended to initiate ADWeb in a single division, CBR implementing organisations in other divisions have requested training on assistive devices. As a result staff from more than 30 organisations outside the target division have participated in ADF and ADM courses.

Concord

ADWeb addresses current needs, which include provision of assistive devices for developing countries, and can be used to collect necessary data to prioritise the needs for specific interventions. With a flexible structure based on existing resources in combination with a potential for nationwide coverage, the ADWeb concept, after refinement, might be considered as a country level strategy when exploring possibilities of global/regional initiatives. Because of the involvement of many organisations, and well-developed mechanisms for information sharing and capacity building, ADWeb is a useful structure for transferring appropriate technology within a country and between countries, as well as facilitating South-to-South collaboration. Participation of users and the involvement of DPOs as major stakeholders are important features of ADWeb.

Bibliography

ADNet. 2000. ADWeb service delivery system for assistive devices in Bangladesh. Dhaka: ADNet.

ANet. 2000. ADWeb service delivery system for assistive devices: policy framework. Dhaka: ADNet.

ADNet. 2000. Proceedings: Service Delivery Subcommittee Meeting 4 April 2000. Dhaka: ADNet.

Borg J. 1999. Accessibility success and assistive device access. Dhaka: InterLife – Bangladesh.

Sharif S. 2004. Compiled evaluation of AD services April 2004. Dhaka: InterLife – Bangladesh

Uddin S. 2002. A model of an appropriate service delivery system for assistive devices in Bangladesh. Project for Bachelor Degree in Rehabilitation Engineering. Borlänge: Dalarna University.

UNDP. 2003. Human development report 2003. <http://hdr.undp.org/>

ADNet and InterLife – Bangladesh documents are available from InterLife – Bangladesh. Address: House 5A, Road 25A, Banani, Dhaka, Bangladesh. E-mail: ilb@citech-bd.com Phone: +880-2-88 13 40

Supply and distribution: Supply and distribution systems: a country-wide view, MoH, Uganda

Fredrick Semakula

National Wheelchair Project, Ministry of Health, Kampala, Uganda

Introduction

Uganda, as a developing country that is engulfed in political conflicts, poor health conditions and increasing road traffic accidents, of necessity has numerous wheelchair users. If we can borrow the international estimate of 6% of population requiring use of wheelchair, then Uganda's population of 24 million should have 1.4 million users. The number of people with disability is likely underestimated, due to the difficulty in accounting for 'forgotten' citizens who spend their lives in back yards (Wheelchair Foundation Newsletter, 2003). There is therefore a great need for production and usage of wheelchair.

Reliable data for the number of people in Uganda, who require a wheelchair, is not available. A recent survey estimates 44,400 PWD wheelchair users in the country. This figure excludes the elderly and sick who make a considerable number. It may also under represent districts that have been ravaged by wars where the survey did not reach.

The purpose of this paper is to highlight sources of wheelchairs and their modes of distribution.

Sources of wheelchairs

In Uganda there is now a network of workshops which have the capability to produce wheelchairs: including having the appropriate tools, equipment, jigs, trained technologists and technicians. These produce different designs including tricycles, Huckstep, foldable wheelchairs and three-wheeler rigid. According to the survey, the preference of design depends on the environment terrains and the day today activities of the user.

Unfortunately the rate of local production is far below the demand. Production output of the different workshops largely depends on availability of funds other than demand. This problem runs right from government production units and private workshops. Uganda therefore depends to a large extent on imported wheelchairs most of which are old refurbished and sent as donations. These chairs are unsuitable to the local terrain and difficult to maintain or repair.

An overview of orthopaedic workshops indicates that there used to be four government regional workshops that produced wheelchairs but currently only one is visibly in production. The factors leading to this low production include:

- Low government funding basically because disability is given low priority
- Few trained personnel,
- The scraping of 'cost-sharing' in government workshops
- Bureaucracy that makes the whole process long and tiresome leading to people being discharged without getting a wheelchair or abandoning the whole process
- The distance between the user and the service provider is prohibitive. A person may have to travel 300 to 400 km to the source.

Private workshops have therefore played a key role in bridging the gap. Of these, 2 are found in Kampala, 3 in the Eastern region, 2 in the Northern region and 1 in the Western region. We should note however, that their production rate is dictated by orders which are scanty and irregular. This gives a miserable picture of fairly equipped centres that are redundant on one side and struggling and crawling persons badly in need of wheelchairs on the other side. The missing links include:

- Poverty
- High cost of production of a wheelchair

- There is no direct link between the producer and the user since the consumer in most cases is not the buyer.
- Disabled persons' necessities are not always priority to the family.

The survey mentioned above indicated that 95% of the wheelchairs were donations to the user. Besides the imported wheelchairs that are distributed through local DPOs, Churches, Rotary and other NGOs, there is a significantly growing number of wheelchairs bought by local government using district or sub-county budgets. This, however, is determined by the strength of the local councillors who lobby during budget allocations.

The above finance resources are irregular and not dependable. It is therefore necessary to develop a regular and sustainable system that would be accessed by all who need it. A Wheelchair Financing Committee has therefore been established under the umbrella of the National Wheelchair Coordination Committee (NWCC) and its terms of reference have been set.

The challenge of liberalising production, however, is the tendency to produce poor quality. A mechanism needs to be developed to 'police' the quality of the products and services of each workshop. One way of policing is developing minimum standards and establishing a monitoring team to ensure maintenance of standards. Approved workshops are then certified by the NWCC as 'approved' suppliers.

Another challenge for wheelchair production in Uganda is the high cost or lack of availability of some materials and components. Some initial research into the comparative cost of items was carried out as part of the NAD funded wheelchair project and it is now proposed to build on this to research the potential for centralised purchasing of lower cost items outside of Uganda, and the establishment of a system whereby the network of workshops in Uganda can access low cost, high quality components which will positively affect the quality and price of their products.

Assessment, prescription and distribution

Appropriate wheelchair distribution needs to include individual assessment and prescription of users, and the establishment of a national network to ensure that wheelchairs can be accessed in all regions of the country.

In most local production centres, users are assessed and prescribed if the user is able to reach the workshop or the hospital, or if in some way the producer is facilitated to reach the user. The challenges in assessment are the following:

- The distance between the producer and the buyer. One can only get through the process if he can travel several times to the workshop for assessment, fitting before finally taking the product.
- In most cases the buyer is not the user. A person places an order for x number of wheelchairs without first identifying the beneficiaries. This happens a lot during political campaigns.
- Donated chairs from abroad are also often distributed without assessment and prescription. As a result of mal-fitting wheelchairs are abandoned due to the discomfort they produce but because of the need, the dangers are ignored.
- Majority of the users are completely ignorant of the concerns and dangers of improper wheelchairs and will take and use anything available for their movement.
- The professionals mandated to assess and prescribe are too few for the population and therefore distant from the user.

International guidelines developed for wheelchair services include the provision of 'peer group training' (PGT) or wheelchair user to wheelchair user training as an integral part of a wheelchair service. Motivation is working with the Spinal Injuries Association, Uganda (SIAU) to develop PGT in Uganda and to integrate PGT more fully into the health service structure by identifying and training regional peer group trainers who can ensure that once a user is provided with a wheelchair they are exposed to the necessary skills to achieve maximum independence.

It is also planned that a future initiative will also investigate how services can work with CBR programmes and other structures to establish identification and referral systems.

Repairs and maintenance

Locally produced chairs are found to be easily repairable since most the components used are locally available. The common repairs include replacement of tyres, bearings, seat and backrest canvas, spokes, punctures and minor welding. In most cases the minor repairs are done locally without returning to the workshop.

Donated chairs, however, have proved to be difficult in maintenance. Because of the difficulties of maintenance, 76.7% of the respondents in the research preferred using local wheelchairs. The reasons forwarded include:

- Majority of the chairs are orthopaedic chairs that cannot stand the heavy terrain.
- They are not wieldable
- Their castor wheels cannot be replaced

National strategy for wheelchair provision

Uganda came up with a national strategy draft for wheelchair provision as a result of the 2004 wheelchair stakeholders meeting. The strategy wished to combine both improved provision of services and sustainability. This strategy included the following:

- Establishment of a national wheelchair coordination committee
- Developing minimum standards
- Establishing a wheelchair fund
- Training of the relevant professions
- Training of the users.

Conclusion

There is an attempt to improve wheelchair service provision but the above mentioned challenges leave a lot to be addressed for a better system and mechanism of service delivery. Whatever the approach, we cannot work in isolation of government for a sustainable system. There is need therefore for concerted efforts to lobby government for support..

Plenary discussion: Supply and distribution

Chairman: Santiago Castellon
Rapporteur: David Winters

Hodge: With regard to the criteria to select partners by the Wheelchair Foundation (WF) there are meetings weekly to discuss partners' criteria. There is a lot of screening. Any doubts are reviewed. It is done on a case by case basis. Have some flexibility due to varying factors.

Øderud: Is there an issue of reselling donated wheelchairs?

Hodge: The percentage is very small.

Question to Alimco: What was Alimco's previous model prior to the 'camp' model? Why has Alimco now chosen the 'camp' model?

Dubey: Alimco used to work through regional assessment centres but were not able to reach people in isolated rural areas. There are a small number of beneficiaries in isolated areas.

Hotchkiss: There used to be six wheelchair producers in Mexico producing 4,000 units per year. Large scale distribution may now result in lack of survival of these six indigenous producers. What is the feeling of WF?

Hodge: WF has no intention to put people out of business. Educating one another about best possible way of doing things is ideal.

Curtis: The WF contract is impressive in giving specific standards to be met by distributors. A checklist of direct feedback from each user in form of postcard that comes back to organizations in about a month or so after distribution might be useful. Has Alimco considered a wheelchair design appropriate to the terrain in India instead of only institutional chairs?

Dubey: Alimco already sends prepaid postcard with many questions to each individual user, however, generally responses are not as specific as desired, but there is a response. Most camp models distributed are folding wheelchairs.

To WF: Is there a policy of revisiting past areas where older wheelchairs may need to be replaced now?

Hodge: Yes, WF revisits countries as life span of products ends. Angola is often revisited to monitor wear and tear.

To Disacare: There are problems selling wheelchairs due to imported donations. What were the sales figures in 2005?

Mukwasa: 25-40 wheelchairs were sold per month in 2005. In 2006 sales dropped to approximately 5 units per month due to imported donations.

To Alimco: Is the Bangalore facility in full production? Is Alimco now producing the University of Pittsburgh wheelchair design?

Dubey: Alimco's main production is in Kanpur and satellite centres are currently producing components not full units.

To Alimco: Is Alimco under any impact evaluation for intervention? Is there any evaluation of distribution and camps?

Dubey: Fully fledged surveys and evaluation require funding and a request has been made for funding from government.

Nganwa: There has been a camp approach and outreach in Uganda. The camp approach works best where there is a CBR programme. Some 500 imported wheelchairs have had an impact.

Capacity development: Organisational capacity building, what is needed to establish wheelchair service provision, building the organisation, training personnel, sustainability

Geoff Bardsley
TORT Centre, Ninewells Hospital, Dundee, UK

Introduction

This paper reviews the considerations involved in establishing a wheelchair service with capacity to meet needs in a sustainable manner.

For the purposes of the paper, capacity is defined as ability to fully meet needs. This is not possible until a service fully matures, but, nevertheless, should be its eventual goal. Similarly, sustainability is considered to relate to the continuity of the service on a long-lasting basis.

The initial steps in establishing a service should ideally involve developing a vision based on a clear understanding of the population requiring the service. This should involve statistics on their demography as well as an analysis of their characteristics and needs for wheelchairs. The vision for the service should also be based on close dialogue with all stakeholders.

Provision

At the core of any sustainable service is the process of provision. All the following elements are required organised in a sequential recurrent process. They include referral, assessment/prescription, procurement, delivery, review and repair/maintenance, as follows:

- **Assessment/prescription:** requires to be based on clear procedures and defined prescription criteria. Defining objectives at this stage is important for clarity for staff and users alike.
- **Procurement:** involves obtaining the wheelchair specified during prescription. Procurement may be simply a process of taking devices from a limited store of equipment provided externally or as complex as sourcing suppliers, agreeing contracts, bulk purchasing, storage, etc. A range of devices is essential and it is wise to establish a range of suppliers and/or local manufacturing capacity. These sources need to be reliable and able to match the rate of provision of the service.
- **Delivery:** may involve fitting, training of the user and transporting the wheelchair to their home. It is advisable to check that the wheelchair meets the original objectives as identified in prescription – a very useful Outcome Measure.
- **Review and repair/maintenance:** are essential elements of any service to ensure wheelchair continues to meet users needs and that it continues to function satisfactorily.

Users

Users are considered to be at the heart of any wheelchair service and need to be fully integrated into its operation. They have a valuable role in ensuring that the service is relevant to their needs and can be powerful advocates in obtaining resources.

Staff

Staff are considered the most valuable asset of any service and should be drawn from a range of disciplines. Training is essential for them to be able to fulfil their roles adequately. A sustainable service needs to pay particular attention to support its staff and provide training opportunities. Career planning and succession management should be included.

Infrastructure

A range of supporting 'infrastructures' are required to ensure any service is sustainable. These include the following, although this is not necessarily an exhaustive list:

- **Facilities:** clearly a location is required to form the focus from which a service can operate. This would normally include clinical, administrative, storage and workshop areas.
- **Networks:** a network of connections enables a service to be fully in touch with users and their associated services. A 'hub and spoke' model can be used to link core services with satellite clinics and further outreach resources through Community Based Rehabilitation (CBR) Services. The use of existing networks and resources such as for Prosthetics and Orthotics can help considerably in establishing a Wheelchair Service.
- **Quality assurance:** some form of quality assurance system, however rudimentary, is essential to ensure that a service meets its objectives in a reliable and appropriate manner. This requires setting objectives, defining procedures, identifying standards, monitoring activity and modifying the service as required. A good record-keeping system is basic to quality assurance and is best done using computers, but can be implemented by hand-written methods. International agreement on structure and content of records would greatly help communication and comparison of services across different countries.
- **Management:** requires strong leadership with close involvement with staff and all stakeholders of the service. Users can have a valuable role whilst close communications with funding agencies is essential.
- **Funding:** may be available initially to start a service from a wide range of sources including charitable donations, NGO/Government initiatives, research projects etc. These can be very helpful in obtaining facilities, equipment and wheelchair stock. However, obtaining recurrent funding to establish the service on a more permanent basis is more difficult. Government funding is considered, by far, the most likely to offer this sustainability of funding as the core of the service. Other less reliable funding sources may then be used to complement this core funding.

Summary

Establishing a service which adequately meets users' needs in a reliable and sustainable manner is one of the most difficult challenges in this field of work. The above factors are recommended to consider in this process. In particular, a clear vision of the service based on user needs is required. Initially services may benefit from short-term monies to initiate their operation, but eventually, reliable funding is required for sustainable operation and is most likely to be provided from government-based resources. The contributions of user support, backed up by evidence of the benefits of the service, can be invaluable in persuading governments to provide the necessary security of funding.

Capacity development: Organisational capacity: Albania Disability Rights Foundation

Florida Kalemi
Albania Disability Rights Foundation, Tirana, Albania

Introduction

The republic of Albania is situated in South East of Europe; Southwest of Balkan Peninsula, along the Adriatic and the Ionian Seas. Albania covers 28,748 square kilometres and has over three million inhabitants.

Disability in Albania

Just as with all other aspects of development in Albania, to understand the context surrounding disability today, one can not ignore the dramatic change which shook the country at end of 1980s and continues to have a drastic impact on people's lives. In just two years, Albania changed from being an extreme communist country, which it had been since the Second World War, to an extreme capitalist country. This dramatic move from nearly total state control and state provision to one in which the state control is limited and its role in service provision is even less, explains much of the current situation.

Neither the private nor public sector currently provides sufficient services either in quantity and quality, so the most at risk suffer the consequences of service insufficiency. Among this population, disabled people are the most vulnerable as they are deprived of health and social care, employment and freedom of movement, education, personal integrity and social security.

Since the riots of 1997, some positive changes have taken place. The new government that came to power after the period of unrest seems to be trying to address the problems facing the country and people in a positive responsible way. Civil society has grown and developed and many signs of partnership between civil society organisations and government organisations are present.

However, choices seem to be still limited by greater economic and political forces, while polarisation between extreme wealth and poverty continues. Meanwhile, political instability and corruption continue to dominate life. Most foreign funding is rapidly being withdrawn from Albania and threatening the collapse of many important schemes and initiatives, particularly those supported by civil society organisations. This is happening at a time when these schemes are at the point of harvesting many of their seeds, but are not yet capable of achieving independence and self-sustainability.

Disability organisations are also actively involved in different initiatives aiming to address problems disabled people face as a result of improperly built and functioning systems of services and care in Albania. There is a serious lack of reliable information about the nature and prevalence of disability in Albania. Based on the official statistics from the Ministry of Labour and Social Affairs there are approximately 80,000 disabled people in Albania (2.3% of the population), however, WHO figures indicate the real figure is between 7-10% and the European Community cites an increasing figure of 14% - 20% of a total population.

The actual system of social services, state policies and legislation offer insufficient programmes of social support in two forms:

1. Institutional care, there exist state services for assessment and rehabilitation in form of two Day Centres and six Residential Centres with a limited capacity of 288 children. Other disabled people live in orphanages, psychiatric hospitals, with poor treatment and frequent violation of their basic human rights.
2. Financial assistance, provided as economic assistance or invalidity pension averaging US\$50-60 per month. People with visual impairments, disability through employment and spinal injuries receive extra assistance but still not sufficient to feel their basic needs.

Although legal frameworks exist, they are fragmented and only sporadically implemented in areas such as education, employment, accessibility.

The Government seems to acknowledge the role, expertise and professionalism of not for profit organisations in the disability sector. Progress based on partnerships, could be noticed in the development in disability area, mainly in political level; an outcome of continuous lobbying and advocacy of disability organisations. In January 2005 efforts by the Albanian Disability Rights Foundation resulted in compiling and approval by the Albanian Government of a National Disability Policy based on principle of equal opportunities. Yet this marks only the beginning of a harder process of implementation of a 10-15 years action plan following this policy paper.

Albanian Disability Rights Foundation

The Albanian Disability Rights Foundation (ADRF) was registered as a local cross-disability not for profit organisation in 1996. From 1994–1996 the programme was developed as part of OXFAM's disability unit, and technical staff and expertise were provided with the vision and mission formulated in line with OXFAM's approach; the social model and the formation of a disability organisation with a rights based approach bringing all stakeholders together.

ADRF was established with four aims:

1. to change the concept and treatment of disability by promoting a human rights approach;
2. to create a cross-disability organisation that would represent a fair, impartial and unbiased judgment for all categories of disabled people;
3. to enable stakeholders to build a forum for exchange of information
4. to stimulate and influence policies and legislation for the benefit of all disabled people and their family members.

The Miresia Wheelchair Workshop was set up in response to the need for mobility means as a precondition to participation.

Four broad categories of stakeholders defined have been widely involved and consulted in all ADRF programme developments, namely:

1. Disabled people, families of disabled children and disability organisations;
2. Relevant governmental institutions;
3. Civil society actors, NGOs, media, business community, community at large;
4. International organisations and the donor community.

ADRF's main programmes are developing a disability rights resource centre, the Miresia wheelchair production workshop, and a subsidising unit.

ADRF's major achievements to date include:

- increased capacities of partner DPOs,
- improved policy and legal framework for disabled people in accessibility, inclusive education, electoral access,
- National Disability Strategy for disabled people,
- mobility equipment produced for over 2,000 people throughout Albania, and
- increased awareness and improved attitudes towards disabled people and disability issues in Albania.

Low cost wheelchairs for Albania

Since January 1996 ADRF has functioned as the lead agency in the establishment, organisation, management and financial administration of the Low Cost Wheelchairs for Albania project. The programme was response to a request from disability NGOs which had identified the need for a low cost wheelchair production and distribution service in Albania. Prior to its establishment, wheelchairs were very difficult to find. There are no other wheelchair producers in Albania due to a lack of expertise (the wheelchair staff has been trained by Motivation) and the discrepancy between the high cost of wheelchairs and position of wheelchair users among the poorest of the society, meaning private enterprises unlikely to undertake such a business.

The OXFAM network has been a very active partner contributing in creating the workshop, providing Miresia with all necessary support such as equipment, training and funds to cover setting up costs. Funds have also been raised from NOVIB, the Japanese Government and Handicap International.

Since 2001 efforts have been directed to achieve self-sustainability. Miresia was facing difficulties due to poor infrastructure, lack of space, quantity of production, increasing producing costs, and old machinery. In 2001 NOVIB was approached by NUON, a Dutch electricity company, seeking a technically oriented development project to encourage its employees to invest in improving other people's lives. NOVIB saw this as an opportunity to properly give Mirësia a chance to develop into a commercially viable workshop. As a result of the cooperation between NOVIB, NUON and ADRF investments were made in a new building, machinery and staff capacity building. This has not only contributed towards sustainability of the Miresa factory, but added to ADRF's ongoing advocacy efforts, and for the first time in 2004 the Albanian Government began to give financial support to the factory. The manufacturing capacity of the workshop is currently 30 wheelchairs per month.

The main objective of workshop as one of the main parts of ADRF programme remains the same; to put into practice the UN Standard Rules on the Equalisation of Opportunities for People with Disabilities, through the provision of mobility equipment as a means towards independent life, towards integration, education and employment.

ADRF uses a holistic approach towards addressing the needs of wheelchair users in Albania. Through its programme it not only offers mobility equipment to disabled people but also the chance of employment in wheelchair production and training, education and support in wheelchair living skills, basic active rehabilitation, advocacy, disability rights and legislation. Advocacy was focused in the area of exclusions of barriers, mainly towards full inclusion and participation of PWD, mobility means users.

ADRF has also been initiating an active rehabilitation movement within Albania. In 1996 the first national Active Rehabilitation camp was held, providing Albanian wheelchair users with the opportunity to gather together with other wheelchair users to learn wheelchair skills, health issues and generally how to gain the most from their new wheelchair. Thirteen wheelchair users participated from different regions of Albania trained by 4 foreign trainers from the UK and Poland. Since then nine national Active Rehabilitation camps and two local Active Rehabilitation camps have been held attended by 295 wheelchair users.

From 2004-2007 the Miresia wheelchair production program has been mainly supported by USAID through the Leahy War Victims Fund. In 2004 and 2005 the Albanian Government finally gave two orders for the procurement of wheelchairs for disabled people under social insurance scheme. More than 2,000 wheelchairs have been produced and distributed to people of all group ages throughout Albania. There is still a great need, and ADRF is striving for sustainability of the Miresia wheelchair production factory, in order to respond to the need for supply with wheelchairs and other relevant supportive services, in order to *“facilitate access by persons with disabilities to quality mobility aids, devices...provide training in mobility skills to persons with disabilities and to specialist staff working with persons with disabilities... ..encourage the produce mobility aids, devices and assistive technologies to take into account all aspects of mobility for persons with disabilities* (UN Convention on the Rights of Persons with Disabilities).

Capacity development: Organisational capacity: APD Bangalore, India

VS Basavaraju The Association of People with Disability (APD), Bangalore, India

Introduction

The Association of People with Disability (APD) is a voluntary organization working towards creating equal opportunities for people with disability through the provision of education, therapy, mobility aids and vocational training and employment.

APD's vision is to work towards ensuring good quality wheelchairs along with support services.

APD, in partnership with Motivation UK, established wheelchair provision in 2004. The purpose of this partnership is to standardize the quality of service for wheelchair users and to aim to provide more appropriate wheelchairs for wheelchair users' needs, disability and living environment.

The present scenario in India

Currently 5-6% of the total Indian population is disabled and out of every 100 disabled people, 10-12 people need a wheelchair. Approximately 70% of the population lives in rural villages with only mud and narrow roads. 42.5% of people with disabilities are women. Many disabled children and adults have to crawl on the floor due to the lack of wheelchairs.

Wheelchairs at APD

There are currently three different types of wheelchair produced at APD:

1. Orthopaedic & Pediatric Wheelchair
2. Foldable, Non-Foldable and Detachable Wheelchair.
3. Motivation Worldmade Wheelchair

Service team

The wheelchair service team consists of:

- Clinical staff
- Technical staff
- Peer trainers

The role of the service team is to assess, measure, prescribe and fit wheelchairs to the user, and to carry out basic repairs. There is a team of professionals which consist of a physiotherapist, occupational therapist, orthotic and prosthetic technicians, CBR workers and special educators.

Training wheelchair users

Wheelchair users along with the attenders/care givers are given two days training once they access the wheelchair service in the following areas:

- Mobility
- Access
- Wheelchair maintenances
- Health related issues
- Independent living

Quotes from Worldmade wheelchair users:

"After using this wheelchair, I feel very confident as I have the freedom of movement. I can go shopping by myself and travel up to 3km independently."

Dilip, Mandya District

“This wheelchair is very convenient as I can go to the bathroom without any assistance. It is so comfortable that I no longer suffer from pressure sores. I can travel up to 3km without any help, which gives me a lot of freedom.”

Hanumanth Raju, Doddabelapur.

“I have a lot of confidence after I started using this wheelchair as I can move independently. It has a comfortable seat and back rest. With the help of the foot rest I can climb easily into the chair. I am no longer afraid of falling, as it is very stable and can go on any terrain.”

Lingaraj, Chamrajnagar dist.

Policy makers' involvement

To improve quality services and prepare people with disabilities to access quality services, APD constantly involves a number of stakeholders in developing policy including heads of other organizations, government departments, doctors and other wheelchair manufacturers.

Conclusion

APD is promoting the wheelchair users to come together to voice their needs, concern and to get their due rights in the society. We have made a start... but there is a long way to go.

Website: www.apd-india.org

Capacity development: Training: formal training; TATCOT/Motivation

Yona Ezekiel Gyundi¹ & Christine Cornick²

¹TATCOT, Moshi, Tanzania

²Motivation UK, Bristol, UK

Over the past thirty years there has been significant development in the field of Prosthetics and Orthotics in low income countries and an increasing recognition of the prosthetics and orthotics professions and their integration into health service structures. The related field of wheelchairs has not kept pace and has often been treated as an 'add-on' to prosthetics and orthotics services or left to donor organisations to address.

The current production and distribution of appropriate wheelchairs is not adequate to meet users' requirements. There is a high reliance on denoted imported western wheelchairs that are not suitable for the local environments or users' physical needs, and which are not provided through health service structures. The limited production of wheelchairs that does exist in low-income countries tends to be copies of western designs, unsuitable for local needs.

Due to such challenges, there is then a great need to train professionals to carry out local wheelchair production and distribution that meet the users' environmental, physical, and economical requirements.

To address this need, The Tanzanian Training Centre for Orthopaedic Technologists (TATCOT) and The Motivation Charitable Trust UK (Motivation) collaborated on the development of a one year course in wheelchair technology, which enrolled its first students in 2000.

The one year Wheelchair Technologists Training Course (WTTC) is conducted at TATCOT: one of the first supra regional training centres in Orthopaedic Technology in Africa. It is based at the Kilimanjaro Christian Medical Centre (KCMC), and under the shade of Mount Kilimanjaro, the highest freestanding mountain in the world. Based within a hospital environment, training is made successful and smooth through collaboration with other rehabilitation service professionals available in the hospital such as Orthopaedic surgeons, Doctors and Physiotherapists.

The aim of the course is to qualify wheelchair technologists who have the practical skills and knowledge needed to fabricate and prescribe appropriate wheelchairs and to manage a self-financing workshop. The WTTC was evaluated in 2005 and has been accredited as equivalent to the level a Category-II Lower Limb Prosthetics or Lower Limb Orthotics training.

The broad objective of the one-year certificate course is to qualify Wheelchair Technologists who are:

- equipped with practical skills and knowledge enabling them to appreciate the design, selection of devices, and prescription of wheelchairs to people with different disabilities
- equipped with the practical skills and knowledge to select locally available materials, components and other resources suitable for wheelchair fabrication
- able to fabricate wheelchairs which provide the intended function, are durable, easily maintained, cosmetically acceptable and affordable by users
- equipped with the skills and knowledge required to develop appropriate designs, assemble parts, and set up procedures for wheelchair fabrication to meet the requirements of the local community
- competent to serve within a rehabilitation clinical team and participate in improving quality, service delivery and community-based rehabilitation

- knowledgeable, motivated and capable of educating technicians working in a wheelchair workshop with the aim of maintaining and continuously improving the quality achieved
- able to show understanding of professional ethics and appreciate the individual social, cultural, psychological and economic factors which influence the process of production, provision and utility of wheelchairs
- Capable of managing, co-ordinating and supervising the daily working activities of the technicians engaged in a wheelchair production workshop.

The duration of the course is one academic year, commencing in October. The course has the capacity to admit ten students each year. Course time is split between theoretical training (20%), practical training (70%) and examinations (10%). The areas of training in Wheelchair Technology include:

Anatomy and Physiology to provide knowledge of body structures and functions

Pathology to identify causes of disability and their wheelchair needs

Clinical Studies to learn skills of assessment and prescription

Technology: Material technology to give a thorough knowledge of materials used and Workshop technology to give the skills and approach needed for wheelchair fabrication.

Wheelchair Service Centre Management to provide skills to run a self-financing wheelchair service centre

Wheelchair Technology to provide skills of wheelchair design and fabrication

Engineering Science including mathematics and mechanics and technical drawing

To qualify for admission, applicants must possess either an Ordinary level education or equivalent certificate, with at least three credit passes in any of the subjects: Physics, Biology, Mathematics or Chemistry. Or candidates may be admitted with lower academic qualifications provided they have two years experience of wheelchair production or repair in a recognised workshop, and pass an entry examination. The course fees are currently US\$8,441.

Since 2000, TATCOT has qualified 36 Wheelchair Technologists from nine African countries, as well as one from Sri Lanka and two from El Salvador.

TATCOT and Motivation are now collaborating with University Don Bosco in El Salvador to develop a two year modular course in Wheelchair Technology which will build on and expand the curriculum to include supportive seating and more clinical content. The first stage of the collaboration has been the training of two UDB staff as Wheelchair Technologists at TATCOT. The modular format is being designed to provide flexibility for students to attend a one or two year training depending on their entry level and career potential, and to enable other allied health professionals to participate in specific training modules of the course. Interest in developing courses on wheelchair technology has also been expressed from other ISPO centres of excellence.

A range of short courses are also planned to be added to the training programme at TATCOT including an assessment and prescription course, and a generic technical course focusing on wheelchair repair and modification.

(Further information about the course is available from the Principal, TATCOT, PO Box 8690, Moshi, Tanzania or tatcot@kilinet.co.tz or www.tatcot.org)

Capacity development: Training: modular approach: Mobility India

Ritu Ghosh
Mobility India, Bangalore, India

There are at least a few million people needing wheelchairs in India. The majority live in rural areas and are usually deprived of basic health care especially rehabilitation services. The majority are also poor and hence cannot afford private facilities. Scarcity of infrastructure and manpower especially at district and sub-district level, keeps many people with disabilities confined inside the house or living in charity. Present training programmes in the field of rehabilitation do not see wheelchairs as a device which needs to be prescribed according to the individual's need or that the user has a choice to select the wheelchair. There is hardly any option to choose an appropriate wheelchair device. There is also not much to choose from; folding or non-folding wheelchair. Tricycles are distributed through camp approaches. "Wheelchairs" are mostly branded for inside use and for outside use "Tricycles" are provided made mostly by the Artificial Limbs Manufacturing Corporation of India (ALIMCO). Most of people making decisions are often neither the professionals who understand the subject nor the users.

Along with Prosthetics/Orthotics and Therapy services, it was realised that wheelchair services are also insufficient in most countries. A similar situation exists in most other low income countries. Considering the socioeconomic condition of the country and experiencing all practical difficulties, Mobility India came to conclusion that an exclusive cadre for wheelchair service would very difficult to develop. Therefore, service delivery models need to be developed that result in the need to develop the skills and knowledge of personnel/professional at different levels meeting the needs of a wheelchair users. The findings showed that there is not a training institution which is conducting structured training programme on wheelchair for rehabilitation personnel. Considering this, Mobility India decided to integrate a wheelchair training component as a module in all its existing training programmes which are:

1. Rehabilitation Therapy Assistant (RTA) course (integrated approach) - 12 months
2. Lower Limb Orthotics - 18 months course
3. Lower Limb Prosthetics - 18 months course

Despite the difficulties in setting up a good wheelchair service provision system in India, seeing the need, Mobility India is establishing a wheelchair service provision as Prosthetics, Orthotics and Therapy services. It was realised that training and service need to go hand in hand and not in separation. With the help of Motivation existing trainers have been trained in different aspects of wheelchair service provision. Mobility India has opted for the Fit for Life course developed by Motivation which includes to be added in MI existing training programmes. It has three modules which are included in existing training programme:

1. Prescription course (Generic) -1 week
2. Worldmade Wheelchair Prescription course -2 week
3. Worldmade Rough Terrain Wheelchair Assembly course -3 week

While these modules are being covered in the regular training programmes, other rehabilitation personnel (usually earlier passed out trainees) including CBR workers could also join the programmes at the same time as add on modules. The training programmes are also intrinsically linked with the philosophy of Community Based Rehabilitation (CBR) programmes. After the completion of training, rehabilitation personnel will have following skill and knowledge:

1. Carry out a safe and basic assessment of a wheelchair user;
2. Prescribe, order and fit the most appropriate wheelchair available.
3. Instruct the user in the safe use of the wheelchair

There is a positive impact for people with a disability who have better opportunities to choose and exercise greater independence/integration. Rehabilitation personnel are developing better understanding now that wheelchair provision is not a one time affair or just distributing them. Optimum use of the wheelchair is more important than just handing it over.

The course is fairly new and it is evolving in response to feedback and developments in different rehabilitation approaches. It needs to be further developed to be reflective of local needs, environments and local resources. MI in collaboration with Motivation have begun to address these problem of service provision in rural India and beyond. There are a lot of possibilities especially for further reinforcement such as review of existing curriculum in the context of wheelchair content, training of trainers, knowledge and skill of service providers, training of user, proper infrastructure for training and service, accessible environment and greater varieties of wheelchairs and accessories.

Training needs to be on a larger scale. Greater advocacy work is needed to add such modules in all existing training programmes of rehabilitation personnel especially those in the field of Physiotherapy/Occupational Therapy, Prosthetics/Orthotics and Physical Medicine and Rehabilitation. Better knowledge and skill will definitely facilitate better service for people with disabilities and trainers which will ultimately assist them to become an equal member of society.

Bibliography

Ministry of Social Justice and Empowerment. 2001. District Rehabilitation Report. Ministry of Social Justice and Empowerment, India.

Mobility India. RTA, LLO and LLP course curriculum.

Motivation. Fit for Life course outline.

WHO. 2005. Guidelines for training personnel in developing countries for prosthetics and orthotics. Geneva: World Health Organization

Capacity development: Training: skill development in a production context: HI France

Philippe Mazard
HI France, Lyons, France

Introduction

The following paper discusses skill development in the production of wheeled assistive devices (WADs), which are mobility assistive devices equipped with wheels.

Context

This modular training programme was originally designed for use in the context of French-speaking West Africa, aiming to address the following points:

- the number of working disabled adults with problems of mobility, mainly as a result of polio,
- there was no large-scale production of mobility assistive devices in the region.

Objectives

The objectives were to:

- meet the mobility needs of a population essentially of polio sufferers in an urban or rural environment in Africa.
- produce WADs in workshops with little equipment and relatively simple tools so that other similar production may be set up throughout the region concerned.

Background

Wheelchair manufacture in West Africa was limited to small welding workshops set up by religious congregations or Disabled People's Organisations. Unfortunately, the models produced were often of poor quality or not suited to the local context as they were a reproduction of European models.

Poor quality:

- low skills level of the technicians manufacturing WADs
- low ergonomic quality of WADs
- workshops under-equipped
- no production aids (templates)

Unsuited to the local context:

- often a copy of European models
- no road infrastructure (or in a very poor condition) requiring sturdy WADs for rough terrain
- models not suited to the residual capacities of the users' different pathologies.

Much better suited was the tricycle, which was introduced by the Orthopaedic Centres for French War Veterans from the Colonies, which distributed a large number of hand-powered tricycles. As this type of tricycle is very popular, there have been many copies or attempts to copy it and this product is still very much in demand.

At the time, Handicap International (HI) was working with a workshop in Ouagadougou in Burkina Faso, which had been manufacturing tricycles for many years. Technicians went there for training where they helped with the production. The training was not structured, but it still helped the trainees to progress.

So as to obtain better results from this training, not disrupt the running of this workshop and be able to reproduce it in other countries, the training was then formalised. The head of this workshop subsequently became a trainer himself.

Strategy

HI has decided to assist a multitude of small workshops in producing WADs, with the aim of obtaining optimal geographical cover. By basing ourselves in already existing workshops, we are also assured of its economic viability.

The models selected must be producible in workshops with little equipment (pipe bender machine, welding station, basic tools).

The models taught have standard dimensions and cannot be adapted. At best they can be adjusted. Fabrication will be based on the use of templates (jigs) to keep manufacturing defects to a minimum. Accompaniment and follow-up will be provided after the training by the HI teams on site in the country.

Preliminary study

Potential workshops are identified via a preliminary study. They are selected on the basis of their desire to produce this type of article, the quality of their work, their skills and also their geographical location.

Training

The technicians identified usually already have the technical level required for this type of manufacture and should therefore be able to take part in the training without difficulty. However, it is possible to organise some prior training with technical schools or training centres for technicians who are motivated but not up to standard. Technical skills in welding and metal work are essential for the training.

Once enough workshops have been identified, we can organise a training course for a group of welding technicians.

The course is made up of 8 modules and lasts three weeks. The level of difficulty increases gradually, starting with a simple production and ending with more complex mechanisms. Each trainee practices and produces all the constructions and is followed up individually to make sure that he has fully understood each exercise.

For each model a written training aid is provided that the trainee can keep and that will help him remember what to do when he returns to his workshop.

Accompaniment

Once the training is over and the technicians have returned to their workshops, the workshop is helped to start its new production:

- creation of working capital by providing the materials needed for the first production series and by purchasing this first series.
- provision of additional tools needed for the production
- technical support for setting up the production
- promotion of the workshop and its production with prescribers, associations, users

Training

It was decided to use a modular approach to the training because not all workshops producing WADs have the same needs, the same skills, and the same experience.

All the participants must at least have good welding skills and they are assessed to determine whether their level is sufficient. When necessary, a course is arranged in a training centre or technical school to bring the technician up to the required level. Welding skills are a pre-requisite without which the training cannot be carried out correctly.

The technical solutions presented during the training are deliberately simple and require only basic tools. The aim is to keep the manufacture of WADs within the reach of all the workshops, however well they are equipped.

The course lasts three weeks and contains 8 modules:

1. Manufacture of a simple wheelchair	12hrs
2. Mounting and adjusting a wheel	4hrs
3. Production of a hand rim	4hrs
4. Hand-powered tricycle	32hrs
5. Fork for a hand-powered tricycle	12hrs
6. Lever-powered tricycle	40hrs
7. Calculating the price of WAD	4hrs
8. Security in the workshop	4hrs

Details of the modules

1. *Manufacturing a simple wheelchair*
Tube-bending using a mechanical bender, as many workshops do not have this tool to begin with.
Learning to produce a simple template (flat), explaining the basic principles and demonstrating how it is useful.
Observation of the participant's technical work by the trainer.
2. *Mounting and adjusting a wheel*
Learning to mount and balance a bicycle wheel.
3. *Production of a hand rim*
Adapting the wheel of a lorry to produce a ring of metal tubing with a diameter wide enough to be used as a hand rim on a wheelchair.
4. *Hand-powered tricycle*
Producing a tricycle frame and a complex template (three dimensional)
5. *Fork for a hand-powered tricycle*
Modifying a bicycle fork for use on a hand-powered tricycle.
Producing a jig.
6. *Lever-powered tricycle*
The focus is on the drive and propulsion mechanisms of the lever-powered handlebars.
7. *Calculating the price of WAD*
Practical exercise in calculating actual production costs, taking into account all the workshop and salary charges, as well as the cost price of the WADs.
8. *Security in the workshop*
Awareness of the dangers involved when using certain tools (electric welding).

During the course, each student is involved in producing each WAD. Whenever possible, the participants take the different jig produced during the training away with them.

Documentation for each exercise

Written documents containing diagrams and drawings are provided for each module. The trainee therefore leaves each module with a training aid that will help him in implementing the technical solutions he has studied once he is back at his workshop.

The documents contain the following:

- an explanatory text
- an illustration showing the key aspects of the module
- a technical diagram including the dimensions and characteristics of the materials used.

Conclusions

- The training is short, mainly practical and enables small-scale production to be set up.
- Simple welders can produce quality WADs.
- This know-how can be introduced throughout the country, where there is demand.
- Its economic viability is ensured as production is introduced into existing workshops.

- As an addition to existing activity, it helps diversify the production of workshops which also continue manufacturing gates and other metal-workproducts.
- These small workshops can also provide maintenance and repair for the WADs they produce.
- The range of models proposed is deliberately limited.
- The workers would not be able to carry out adaptations without guidance from competent medical personnel.

Results

Ten training courses were organised between 1997 and 2003 (Benin, Senegal, 2 in Central African Republic, 2 in Burkina Faso, Guinea-Bissau, Niger and Democratic Republic of Congo).

Some 41 people have been trained from 9 different countries:

- 4 from Benin
- 3 from Togo
- 3 from Mauritania
- 5 from Mali
- 5 from Senegal
- 5 from Central African Republic
- 6 from Guinea-Bissau
- 5 from Democratic Republic of Congo
- 5 from Niger

A study is currently underway in Senegal, Togo and Burkina Faso to determine whether these workshops have continued producing WADs and in what conditions.

The study shows that out of the 11 workshops audited, the production since 1997 is as follows:

▪ Hand-powered tricycles	2499 units
▪ Lever-powered tricycles	593 units
▪ Wheelchairs	<u>142 units</u>
Total	<u>3234 units</u>

Around 63% of these workshops work on prescriptions from functional rehabilitation centres

Around 55% of orders are subsidised by the social security

Around 55% receive orders from hospital poverty funds

Around 63% receive orders from charitable organisations

Capacity development: Training: short courses in assessment and prescription/ assembly and fitting

Kylie Mines
Motivation UK, Bristol, UK

The need for short courses

There is a pressing need for local staff able to work with wheelchair users to select and fit the most appropriate wheelchair and provide follow up and support in maintenance and repairs.

Short duration courses can be an effective way of increasing the number of local staff in developing countries who have at least basic knowledge and skills in wheelchair provision.

The advantages of short duration courses include:

- Reduced course costs,
- Increased accessibility to the course – as staff in existing positions are able to be released to attend the course,
- Short courses can compliment other training programmes – for example programmes of training in CBR, prosthetics/orthotics, physiotherapy, occupational therapy.

An example of a short course: the Fit for Life wheelchair prescription course

Introduction

The Fit for Life wheelchair prescription course was developed by Motivation over a period of two years, including three pilots. The course is now available through Motivation and our partner Mobility India.

To date, the course has been delivered five times; three times in Sri Lanka, once in Papua New Guinea and once in India. Some 46 students from five countries (Sri Lanka, India, Nepal, Papua New Guinea and Zimbabwe) have participated, and 41 have passed.

Training package

The course has been developed as a complete package, which includes a trainer's manual, student workbooks and supporting training material. The training package format has the following advantages. It:

- enables the course to be easily replicated, and delivered by different trainers, to a similar standard,
- reduces preparation time for delivery of each course as all of the material has already been developed,
- increases potential for the training to be scaled up.

Target participants

The target participants are non-professionals. The course requires literacy, ability to problem solve, work with people and a genuine interest in people with a disability. Examples participants include:

- CBR workers / volunteers
- Qualified nurses, physiotherapists, occupational therapists, prosthetists/orthotists, doctors or other health/rehabilitation workers
- Wheelchair users with an interest in working with other wheelchair users in a clinical role.

Characteristics of the course

The course is run in a very participatory, interactive style. Key characteristics include:

- Wheelchair users are actively involved in assisting throughout practical sessions,
- Illustrated characters are introduced at the beginning of the course, and are used to illustrate key learning points throughout,
- Assessment is carried out throughout the course, using a standardised system of competency assessment.

Scope and skills taught

The course covers generic wheelchair assessment to a 'basic' level. It does not cover modifications or complex postural support and does not cover in any depth the specific needs of children. The course focuses on providing participants with the skills required to competently carry out the *clinical role* in each of the following eight key steps in service provision:

- Referral and appointment
- Assessment
- Prescription
- Funding and ordering
- Product preparation
- Fitting
- Wheelchair user instruction
- Follow-up, repairs and maintenance

Lessons learnt in the development of the Fit for Life wheelchair prescription course

Course length

To date the course has been run over two weeks. Feedback has strongly indicated that trainees require more time towards the conclusion of the course to practise their skills, before returning to their workplace. To enable this period of skills consolidation, the course is being extended to three weeks. It is hoped that with this extension of time within the course, trainees will be more able to implement their skills within their own work environment.

Need to support service development

It is clear that the provision of training in isolation of overall service development will minimise the effectiveness of the training. Training needs to be supported and complimented by service capacity development, management training and awareness and follow up of participants in their workplace.

Long term view

Trainees completing the Fit for Life prescription course are provided with skills to work with wheelchair users who do not require modifications/postural support. Once staff begin practising, they quickly realise that there are many wheelchair users that they are unable to provide an appropriate wheelchair for without further training and appropriate products. Participants from the courses to date are already requesting further training, and support in increasing the range of products available to meet the needs of wheelchair users. A long term view in planning training therefore needs to be taken from the beginning, recognising that some of the participants of basic training will have the capacity to undertake further training, better enabling them to meet the needs of a broader range of wheelchair users.

Further development of short courses

Motivation is currently developing the following short courses:

- Training for trainees of Fit for Life prescription course,
- Wheelchair and postural support training for ICRC, with a training of trainers component,
- Supportive seating, Sri Lanka
- Identification and referral training for CBR workers or equivalent.

Capacity development: Training: capacity development of the clinic team

Michiel Steenbeek
CBM, Kampala, Uganda

Introduction

This paper is based on personal experiences regarding provision of wheelchairs mainly in East Africa, and interviews with colleague-therapists.

Present situation

The first question that comes to mind when talking about 'Capacity development of the clinic team' is: who is the clinical team and who is the trainer? Another question is who has received formal training in 'assessment, prescription, production, fitting and wheelchair-user instruction'? None of the present training institutions for doctors, physiotherapists, occupational therapists or orthopaedic technologists includes this in a serious manner in their curriculum. However, these are the professionals that are normally involved in the provision of wheelchairs. How do they become skilled, or build their own capacity? In Canada and other western countries, it is mostly the therapists who, after their formal training, attend an on the job training in specialised centres. Occupational therapists and physiotherapists then become "seating therapists" and work together with "rehabilitation technicians" who actually put the wheelchairs together. The therapists do all of the measuring and assessing and the technician actually builds the chairs to the therapists' requirements. In addition there are rehabilitation engineers who design equipment to meet complex needs.

In the developing world we see a similar situation. Newly qualified therapists and other professionals have little knowledge about issues related to wheelchair provision, nor are they aware of the expertise of the others. Therapists and technicians receive an on-the-job training after their formal training, often in specialised rehabilitation institutions and wheelchair production workshops. Conferences and specialised training organised by international organisations and a few national rehabilitation programs have increased the overall knowledge and professionalism. The planning by the Pan African Wheelchair Builders Association (PAWBA) to hold conferences every 3-4 years is also likely to further the professionalism in this field. The best initiative in East Africa, I believe is the establishment of the Wheelchair Technologists Training Course by Motivation and TATCOT in Moshi, Tanzania.

Yet, a consensus to have integrated training programmes across (para)medical schools and therefore a clear team approach afterwards is largely still absent.

Intervention fields and critical issues

Formal training courses

Provision of appropriate wheelchairs can only be successful on the basis of a full understanding of the different needs of the wheelchair-user. The person's physical, environmental and social needs must be taken into consideration. Therefore the ideal team would consist of the client, a social worker, a wheelchair technologist, a doctor, a physiotherapist and/or an occupational therapist. One of the team members should be a qualified councillor as well. Ideally some of the team members work in the community with the local DPOs.

The respective training institutions/paramedical schools should expand their curriculum to include all aspects of wheelchair provision including special seating and have joint lectures about the same. This will increase knowledge, clarify team roles, expertise and responsibilities and lead to an improved team approach once in the field.

Postgraduate or informal training courses

There are many factors affecting the outcome of postgraduate or informal training courses. We should consider the quality of the training, the retention of trained personnel and therefore the sustainability of skills and service provision.

- Broad based rehabilitation programmes

As mentioned above, a team approach including several disciplines is needed and should cover more than just the technical aspect of wheelchair building. Stand-alone small-scale production workshops often lack the comprehensive wheelchair service skills needed for adequate assessment, prescription, fitting and instruction. This may result in issuing inappropriate wheelchairs, which in turn can lead to secondary complications like pressure sores or scoliosis.

Postgraduate capacity building should therefore take place in collaboration with broad based rehabilitation programs where all components and expertise of rehabilitation are integrated, including CBR detection, physio/occupational therapy, medical/surgical and workshop components. This underlines the importance and value of a team approach, especially nowadays when the emphasis on special seating is increasing. Funding from (inter)national donors for capacity building in wheelchair service provision should follow the same route.

- Programme management

Capacity building of the clinical team should prioritise programmes with adequate management skills to sustain the programme and retain trained staff. Good management can ensure effective production systems and marketing, sufficient funding, infrastructure and equipment maintenance and satisfactory procurement and cost recovery systems. Staff professional development and retaining trained staff occurs only when a professional programme management implements contemporary employment practices and human resources policies with equitable staff remuneration, career development opportunities etc.

In situations where such management skills are not in place, the capacity building exercise must include training of managers in the above-mentioned fields.

- Model projects

The above mentioned broad based programmes can then serve as model projects for a country/region where training (of trainers), production and provision takes place.

Networking and partnerships with local governments, DPOs and international organisations is of utmost importance for sustainability. Model projects can use their organisational weight to initiate the development of national strategies and policies at government level regarding wheelchair service provision. They can also play an important role in advocacy for wheelchair users and mainstreaming disability in general at a national or international level.

Plenary discussion: Capacity development

**Chairman: Harold Shangali
Rapporteur: Marc Krizack**

Capacity building

Constantine: ADRF presentation outlined its achievements; it should be made clear that in 1996 Albania was in political turmoil making their achievements incredible. It shows what can be done with DPO and outside support.

Gall: Albania must have a high level of education but in Afghanistan there is a low level of literacy and especially for disabled people. Our role is to enable DPOs and disabled people to be part of the service.

Shangali: Agrees that Albania is example of success because of their ability to advocate.

Nganya: On capacity development, it is important that managers of the systems are also brought on board, often wheelchair production and distribution is under the control of a bigger establishment such as a hospital. If a manager who does not know a lot about wheelchairs is not brought on board he/she will continue to marginalize this service. This extends to the national level. Those responsible at national level need to understand the need for wheelchairs. With reference to Handicap International's presentation, the profile of disability is changing from polio to cerebral palsy within east Africa so we now need to look at multiple disabilities. We need to lobby for recognition by government structures. People trained in wheelchair provision at TATCOT are not recognised by these governments. Maybe too much depends on the goodwill of a manager.

Bardsley: A manager needs to be aware and grounded in the experience of the wheelchair service itself. It is beneficial to have managers with some responsibility for practical service delivery, such as clinical work or technology.

Borg: How have APD established the figure for the number old people in India who need wheelchairs?

Basavarju: The number quoted is not reliable.

Hotchkiss: APD figures for elderly wheelchair users are virtually identical to the number in USA. Latest statistic is 1 in 100. I have not found any country that varies much from that statistic. Only war situations make it different where high incidence of disability survival rate is lower.

Training

Horvath: How much time is spent in the Fit for Life course teaching wheelchair user to use, maintain and repair wheelchair themselves?

K Mines: Need to confirm exact amount of time, however, there is an emphasis on training clinical staff on how to train wheelchair users. Half a day is spent concentrating on wheelchair user skills. The part of the course focused on repair is in the technical course and it is important to deliver both courses to the staff

Curtis: Does Motivation absorb participant costs or cost share on the Motivation run courses?

Sheldon: Motivation run courses are intended to be self funding; costs are sought individually for participants through a variety of funders including government where appropriate, participants' employers/organisations or separate funding.

Charowa: Is something being done so governments are aware of this training and support the technologists?

Ezekiel: PAWBA will be working on this issue; however there is still a long way to go.

Cornick: How might this conference support recognition of the courses and WHO guidelines, that governments acknowledge and accept the certificate?

Lindstrom: in the prosthetics and orthotics field, technologists also have recognition difficulties. It is important to develop a national professional association in each country. In West and Central Africa there is an organisation of prosthetic technologists who are involved in networking and continuing training with a federation and association system.

Curtis: Many groups have discussed problems with lobbying the government, has anybody tried to address capacity building of groups they are working with?

Constantine: Lots of groups do that and UK funding requires that capacity building is part of funded programmes.

Horvath: USAID has given money for disability programmes to local DPOs for capacity building.

Shangali: It is very important to integrate what you bring into a country with the existing system including by the DPO.

Semakula: How much time is required to train wheelchair users the wheelchair skills they need? To achieve independence need full participation from participants; however, they may come from far away and have psychological problems. This may need to be repeated many times.

Constantine: Have the presentations been of interest to FWM and WF and is it something they will consider with their own partners.

Schoendorfer: Could guidelines for training be provided to FWM?

Gall: The same question could be asked to Alimco with regards the training and capacity building of their partners.

Dubey: Alimco already has a programme for training in prescribing, assessment and fitting in a camp situation, however there is a lot more to be done. They already have short and long-term training from 1 week to 3 months, but they need trainers with higher skills. This is a bottleneck that needs a lot of attention and needs the government or the agency that is responsible for providing the services to be alert to the creation of a skill base of people who will be service prescribers rather than providers.

Chairman's summary: There is a consensus on a number of issues. However, there is a need to establish the structure that Bardsley outlined. Albania and India representatives show that DPOs play an important role for the success of wheelchair services. Formal training is important as we need trained personnel and it is also necessary to have short-term courses to develop skills. In addition, as Steenbeek explained, we must not waste resources, but use existing resources and short-term courses. Outcome measurements are important and we must implement this to substantiate the type of services we are providing to disabled people.

Guidelines for wheelchair provision: Introduction to draft WHO guidelines

**Kim Reisinger
CIR, Chicago, USA**

Introduction

As noted in the June 24, 2003 USAID Annual Programme Statement, "conservative estimates put the number of people with disabilities in developing countries at close to half a billion. Of these, an estimated twenty million require wheelchairs to be mobile". Less resourced settings often lack adequate or accessible health care services, although there is typically a greater incidence of disabling conditions due to disease, injury, and general poor health. Consequently, many individuals in less resourced settings who need a wheelchair don't have one, and those who do often receive wheelchairs without the associated services and training.

For individuals who are unable to walk, a wheelchair provides the means by which they can exercise their human rights and be equal participants in society. With an appropriate wheelchair, individuals can become independently mobile, making it possible for them to work, study, participate in community life, and access medical care. An appropriate wheelchair that is properly prescribed and adjusted for the individual user can reduce the risk of common health issues associated with an improperly fit wheelchair (e.g. pressure sores). Increased independence and mobility, combined with reduced risk of health issues in general, improves the user's quality of life.

The benefits of wheelchair provision extend beyond the immediate impact for the users to their families, communities, and society as a whole. The provision of appropriate wheelchairs with associated services and training can have a significant economic impact through the reduction of health care expenses associated with the treatment of pressure sores or progressive deformities due to improperly fitted wheelchairs, or the absence of wheelchairs. Economic benefits are further realised as wheelchair users are able to access opportunities for education and employment.

Prior to 1980, wheelchairs for active use in the rugged conditions prevalent in less resourced settings were virtually non-existent. Since that time many international organisations have begun to introduce appropriately designed wheelchairs that could be built and/or repaired in less resourced settings using locally available parts and materials. Several of these organisations have also established service and training programmes, that when combined with an appropriate wheelchair, offer the wheelchair user a comprehensive wheelchair provision programme from which to obtain a properly fitted wheelchair. In addition many national groups in less resourced settings have been working towards finding local solutions to the problem of wheelchair provision.

Efforts by all of these organisations resulted in great advances in appropriate wheelchair design, training and distribution for active use in less resourced settings, but the total number of wheelchairs produced was relatively small, due in large part to the lack of funds available for wheelchair purchases. Generally, people who need wheelchairs are among the poorest and must rely on their governments, international development organisations, and charitable organisations to purchase the wheelchairs they need. Despite these efforts, there continues to be a need for wheelchair provision in less resourced settings. Still, other organisations have attempted to meet the need for wheelchairs through mass distribution programmes that may not provide the most appropriate wheelchair for the user because associated wheelchair services and training are often lacking.

Consensus is needed on what constitutes appropriate wheelchair provision in less resourced settings. There is also a need to develop, disseminate and adopt guidelines containing recommendations and suggestions that will help key stakeholders plan for and implement wheelchair provision programmes in less resourced settings. Adoption of guidelines on the

appropriate provision of manual wheelchairs will ensure that wheelchair users in less resourced settings receive wheelchairs that meet their individual needs; receive wheelchairs that meet basic standards of safety, durability and functionality; receive services that include basic prescription, fitting, training on use of the wheelchair, and follow-up from trained personnel; and are educated to be involved in the prescription and selection process. Guidelines will also provide guidance to those wishing to support wheelchair provision around the world (governments, NGOs and individuals), with assurance that the products and processes they are involved with meet user needs and that money is being spent effectively

This paper outlines the efforts that have been undertaken to begin to build consensus and to develop guidelines; it also outlines the contents of the guidelines.

Approach to development of the guidelines

The goal of this project was to produce a draft document of *Guidelines on the Provision of Manual Wheelchairs in Less Resourced Settings* that would be presented for discussion and consensus at the ISPO Consensus Conference on Wheelchairs for Developing Countries in November 2006, and which would then be published and disseminated by WHO at the 2007 ISPO World Congress. Thus, the action plan and timeline for producing a draft document was driven by these critical dates. The action plan is summarised by the five phases outlined below:

- Phase I: Form consortium
- Phase II: Collect information and prepare draft
- Phase III: Presentation of draft Guidelines for review and consensus at ISPO conference on wheelchairs for developing countries
- Phase IV: Revise draft Guidelines to reflect consensus reached at the ISPO conference
- Phase V: Present WHO published Guidelines at the 2007 ISPO World Congress, Vancouver

Phase I: development of a consortium

In October of 2004, representatives from Motivation Charitable Trust, UK, Whirlwind Wheelchairs, the Center for International Rehabilitation, as well as some individual consultants, met in Washington, DC to discuss the potential for creating a consortium that would address the needs of wheelchair users in developing countries by building consensus on appropriate wheelchair provision in developing countries. At this meeting the group decided to initially focus on the provision of manual wheelchairs, with a goal to draft guidelines for the design, production, distribution and service of wheelchairs for use in developing countries.

Additional consortium members were recruited to ensure representation from varied geographic and service contexts. Participants were chosen based on the activities and accomplishments of their individual organisations in one or more areas of wheelchair service provision (products, service, and/or training) in developing countries. Participants were also selected based on their access to networks that include partners and other groups involved in the provision of wheelchairs. In addition to representatives from the Motivation Charitable Trust, Whirlwind Wheelchair International, and the Center for International Rehabilitation, 10 individuals from the following organisations accepted invitations to participate:

1. Kilimanjaro Spinal Injury Association, Tanzania
2. Motivation Romania, Romania
3. Sandy Gall Afghanistan Appeal, Afghanistan
4. APD, Kenya
5. Independent Consultant, Canada
6. University del Valle Cali, Colombia (2 individuals)
7. Handicap International, Philippines
8. Shonaquip, South Africa
9. University of Pittsburgh, United States

Phase II: development of draft guidelines for presentation at the ISPO consensus conference on wheelchairs for developing countries

Consortium members collected information from their own organisations, other sources, and literature reviews, and from those that they work with, that would be pertinent to the development of guidelines. Collected resource materials were categorised into each of the three primary areas of the guidelines: products, service and training. A Community of Practice (CoP) was established on the Center for International Rehabilitation's IDEAnet to facilitate communication among the members and to serve as a document repository.

In December 2005, members of the consortium convened for a 4-day working session in Bristol, England. Three working groups were formed to review information, and define parameters and outline content for each of the primary areas of the guidelines. The three core organisations of the group assumed responsibility each one of the main guideline sections:

- Products: Whirlwind Wheelchair International
- Services: Center for International Rehabilitation
- Training: Motivation Charitable Trust

Following the December 2005 meeting, a WHO appointed editorial consultant joined the consortium to provide guidance on the further development of the guidelines in collaboration with the WHO. A formal outline was approved by WHO, and the content was expanded to include a section on Policy and Planning and a section that profiles how wheelchair provision has impacted the lives of several individuals.

Consortium members continued to collect and organise information, and communicate with their network partner organisations regarding review and feedback as the draft guidelines were developed. Preliminary drafts of the three major sections (Service provision, Design and production, and Training) were distributed for review between June and July 2006. In addition to the consortium members, reviews were sought from more than 25 external reviewers.

Main sections of:
"Guidelines on the Provision of
**Manual Wheelchairs in Less
Resourced Settings**"

1. Introduction
2. Policy and planning
3. Service provision
4. Design and production
5. Training
6. Changing lives

A complete draft of all sections of the guidelines was prepared for a 3-day discussion and review at the WHO headquarters on August 28, 2006. Further revisions and external reviews occurred during the two months preceding the ISPO Consensus Conference on Wheelchairs for Developing Countries.

Phase III: presentation and discussion of draft guidelines

An extended summary of the *Guidelines on the Provision of Manual Wheelchairs in Less Resourced Settings* will be distributed at the ISPO Consensus Conference, November 6-11, 2006 for review and discussion.

Phase IV: revision of draft guidelines

Following the ISPO Consensus Conference on Wheelchairs for Developing Countries, the WHO editorial consultant, along with assistance from the core organisations responsible for preparing the draft, will revise the Guidelines to reflect the consensus reached at the ISPO Consensus Conference.

Phase V: publication and dissemination of the guidelines

The WHO will publish the Guidelines for presentation and distribution at the 2007 ISPO World Congress in Vancouver, Canada.

Overview of draft guidelines for review and discussion at consensus conference on wheelchairs for developing countries

The purpose of the guidelines is to enhance the quality of life of wheelchair users in less resourced settings through improved access to appropriate wheelchairs.

The guidelines focus primarily on manual wheelchairs and the needs of permanent wheelchair users. Some of the recommendations may be applicable for other types of mobility devices, e.g. hand powered tricycles, and for other types of users, e.g. temporary wheelchair users.

The recommendations are not meant to be comprehensive or prescriptive. Flexibility is required due to the many different contexts in which they may be applied and implemented.

The intended readers of the guidelines are:

- government and non-government policy makers;
- planners, managers, providers and users of wheelchair services;
- designers, testers, donors, purchasers, adapters and users of wheelchairs;
- planners and managers of wheelchair production;
- planners, developers and implementers of training programmes;
- developers of communication and advocacy materials;
- disabled peoples organisations;
- groups of wheelchair users; and
- individual wheelchair users and their families.

The guidelines are structured into six chapters:

1. *Introduction* gives an overview of the guidelines and the need for wheelchairs. It introduces wheelchair users, basic types of wheelchairs, and common approaches to wheelchair provision including wheelchair supply, wheelchair services and training for service personnel. It also describes different stakeholders and their roles.
2. *Policy and planning* provides information to support and guide decisions on wheelchair provision. The purpose of this chapter is to provide strategies to help policy makers implement cost effective and sustainable wheelchair provision in less resourced settings. It presents key activities associated with planning and implementation. It also suggests ways to finance wheelchair provision and ways to link wheelchair services to other sectors.
3. *Service provision*: suggests tasks and structure of a system for provision of wheelchairs. The purpose of this chapter is to improve the way in which wheelchair users receive wheelchairs. It promotes wheelchair provision through services or systems which support individual user assessment, prescription, fitting, instruction, and follow-up.
4. *Design and production* provides recommendations on how to evaluate and select, or develop, the most appropriate design of wheelchair for use, supply or production. The purpose of this chapter is to increase the quality and range of manual wheelchairs available in less resourced settings, and to provide the tools to ensure that the wheelchairs meet minimum requirements for safety, durability, and functionality.
5. *Training* is a tool for the design, development and implementation of training opportunities for personnel involved in provision of wheelchair services. The purpose of this chapter is to improve the way in which wheelchair users receive wheelchairs by improving the skills and knowledge of local staff involved in wheelchair provision. Chapter 5 also includes training for referral sources. It provides recommendations for how training programmes may be provided, and it provides a summary of recommended course content for staff fulfilling clinical, technical, training, and management roles in wheelchair provision.
6. *Changing lives* shows the impact of wheelchairs on the quality of life of people with disabilities. It provides testimonials from six individuals for whom a wheelchair has made a positive impact on their quality of life.

The guidelines are complemented by resource materials that will be available at the website www.who.int/disabilities/ and on a CD, which can be ordered from the same website.

Acknowledgements

Contributors: W. Armstrong, J. Borg, M. Krizack, A. Lindsley, K. Mines, J. Pearlman, K. Reisinger, S. Sheldon

Plenary discussion: Guidelines for wheelchair provision

Chairman: Geoff Bardsley
Rapporteur: Christine Cornick

Johan Borg joined Kim Reisinger to respond to questions.

Hodge: Can a positive story can be included in the last section for a mass donation wheelchair such as a Wheelchair Foundation wheelchair?

Khasnabis: Yes, WHO would like to have contributions from all as WHO is a neutral, unbiased body.

Shangali: Would have liked to have seen the guidelines before. Do the guidelines refer to wheelchair technologists as such?

K Mines: The guidelines include a case study on page 91 and looked at one WTTC graduate. The training guideline has focused on roles and not professions. The guideline notes that someone with technical, clinical and management skills is needed, either through one person or a range of people who collectively have those skills.

Shangali: As a guideline it is important to reflect a training programme that exists and is accredited by ISPO.

Bardsley: This is exactly the sort of feedback required from this group.

Curtis: Is there a resource list within the guidelines?

Reisinger: There is a list for each chapter.

Jensen: The programme at TATCOT is recognised as a Category II programme by ISPO so there should be a very precise reference to it.

Horvarth: The group is considering a website for the resources to prevent it being quickly out of date.

Macdonald: As a draft document can it be assumed that everything that has come out of the consensus conference will be incorporated into it and reprioritised?

Reisinger: The next stage is to use the conference to go back and restructure the document. The driving force was to get it ready for the ISPO World Congress in 2007.

Ghosh: Under point 4: design and production, is research and development missing or is it included?

Reisinger: There is a design and research section looking at a design brief and trials etc.

Shangali: There is confusion regarding what will be done with the outcomes of the consensus conference. What is the relationship between one and the other: the conference and the guidelines?

Khasnabis: Every consensus conference comes with a report and sometimes it is recommended that guidelines are developed. With wheelchair issues we have seen that people want these guidelines now, which is why both processes were commenced simultaneously. It was felt this was the right opportunity to make an introduction to the guidelines so that this is a platform and a sounding board to see how correct the guidelines are. The working group will ensure that most of the recommendations from here will be incorporated into the guidelines. The next draft will be circulated to a wider group but it cannot

go to everyone as it is too difficult to deal with a hundred sets of comments from different people – some people need to be selected to comment.

Horvarth: It was premature in a guideline to say there is a profession, but if there is a recommendation that ISPO should have a recognised category of wheelchair professional that will be incorporated.

Jensen: The WTTC is already recognised by ISPO.

Khasnabis: There will be a peer review then the 2nd draft will be going to Vancouver. It will not be published in Vancouver because these things take time but the group is keen to take advantage of these gatherings.

Shangali: Whatever comes out of this consensus will be published by ISPO/WHO but who will be the owner of the guidelines? Will it be WHO? If that is the case the conference was started without the knowledge of what was the plan.

Khasnabis: It will be WHO guidelines. The organising committee agreed it would be WHO guidelines.

Jensen: When we were asked to organise this conference we were asked to agree to that.

Gall: From a practitioner point of view I do not see it as a problem to use it as a working document in the field if it is a draft.

Bardsley (Chair): It is clear there is a lot of discussion on this area and issues over ownership will need to be discussed outside of this forum. Hopefully the people who are developing the guidelines will be sensitive to that fact.

Bhattacharjee: Do the guidelines go far enough to say how the issue of the great need can be tackled? It is recommended that the document is more directive in recommending local production. It should promote local governments to develop local production.

Horvarth: That is not what the discussions this week have reflected. I have heard more that there are many solutions and we need to find a mix of solutions.

Suvapan: Suggest the guidelines give examples of different possible solutions that countries can adopt based on their resources. There should be a cascade system to show the ideal scenario, then different levels down to show possibilities in different contexts.

Horvarth: Does the document define the minimum requirements for a wheelchair?

Reisinger: Yes.

Basavarju: It looks as if the guidelines are good for the cities, but will they really address the needs of people in rural and less accessible areas? We need to make sure we deal with the real situation.

Borg: The guidelines do reflect the reality on the ground and the rural situation context.

Khasnabis: We found difficulty to get input from developing countries. People from developing countries are often good in conferences but not in communication. A request was made to those from developing countries to give their contributions whatever format it is sent in.

Bardsley (Chair): We need to look then at how can we make it easy for people to contribute.

Khasnabis: There is a need for case studies and examples of good practice. These need to be sent to WHO which is responsible for developing the guidelines.

Gall: It is difficult to give comments from an isolated place and to comment on a document that has not been seen. A written copy would make it easier to comment on.

Tardif: Request clarification for what comments have been asked for.

Shangali: The conference has been positive and it is now necessary for participants to be given the document and to give feedback.

Ilgan: Issues of people with severe and multiple disabilities should be considered to ensure their needs are considered in the guidelines.

K Mines: Suggested that hubs are developed to coordinate feedback.

Hodge: Government should be encouraged to levy VAT on imported wheelchairs to finance local manufacture. Within WF there is a feeling that if a government does not want WF wheelchairs they will not send them there.

Winters: Any country that is a signatory to the treaty would be violating that treaty if they added a tax on imported disability goods.

Armstrong: Regarding the review process, if it is possible to distribute the draft as a whole to people here it might be easier to synthesise feedback. There is something to be gained by seeing the whole document. It would be best to get a summary of the conference report at the same time so we can see that the outcomes of the conference have been incorporated.

Kalemi: An email forum discussion for these guidelines would be positive as discussions within our countries can be held in order to give feedback.

Jensen: Suggest that the conference conclusions and the draft guidelines published so participants can judge whether the conference conclusions are reflected.

Mukwasa: Through PAWBA we can see how we can coordinate comments from our members and give feedback if you give us a deadline.

Noon: Suggest the review team incorporates the findings from this conference quite quickly and get a draft out fairly soon. Also suggested that comments be concise and pointed, to make it easier for them to be evaluated and incorporated.

Ilgan: DPI on a global level would like to be part of the review team. Some 70% of DPI members are wheelchair users.

el Khadiri: Will the guidelines exist in other languages?

Khasnabis: The WHO policy is to publish in six languages if funding is available, but otherwise the country offices might translate it into local languages.

Thanks were given to Johan Borg and the team for their great job with the guidelines.

APPENDICES

**APPENDIX A:
ISPO/USAID/WHO consensus conference on wheelchairs for
developing countries
Bengaluru, India
6th-11th November 2006**

Monday 6th November		
07.30	Registration	
	Opening Ceremony	
08.00	Mobility India	Elizabeth Thomas
08.05	Indian Opening Ceremony	
	Chairman:	Rob Horvath
08.30	Government of Karnataka	Sobha Nambishan
08.35	USAID	Lloyd Feinberg
08.40	WHO	Chapal Khasnabis
08.45	DPI	Venus Ilagan
08.50	ISPO	Harold Shangali
08.55	Government of Karnataka	V Sriramareddy
09.00	Final remarks	Rob Horvath
09.05	Break + Press Conference	
10.00	Objectives and expected outcomes of the conference	Rob Horvath
	Chairman:	J Steen Jensen
	Rapporteur:	Sarah Sheldon
10.10	Needs, poverty and inclusion	
10.15	Needs, human rights, access	Chapal Khasnabis
10.35	User participation	Venus Ilagan
10.45	Approaches to wheelchair provision from USAID's perspective	Lloyd Feinberg
11.00	Review session	
11.05	Review of literature on wheelchairs for developing countries	Jon Pearlman
11.25	Review of wheelchair provision in developing countries	Jon Pearlman
11.45	User satisfaction survey	Tone Øderud
12.05	Discussion	
12.30	Lunch	
13.30	Syndicates A	
15.00	Break	
	Chairman:	Geoff Bardsley
	Rapporteur:	Anna Lindstrom
15.30	Services	
15.35	Referral, assessment and prescription, fitting, basic user training (including peer group training)	Chapal Khasnabis
15.50	Discussion	
16.00	Community based services: Mobility India	Albina Shankar
16.10	DPO based services: Disabled Women's Support Organisation, Zimbabwe	Gladys Charowa

16.20	Institutional-governmental services: China Service for Development & Supply of Devices for Disabled	Chen Guang
16.30	International NGO services: Hope Haven	DVD presentation
16.40	NGO with governmental purchasing: Motivation Romania Foundation	Cristian Ispas
16.50	User satisfaction survey	Tone Øderud
17.00	Discussion	
17.30	Close	
18.00-19.00	Opening Reception: Mobility India	

Tuesday 7th November		
	Chairman: Rapporteur:	Harold Shangali Johan Borg
09.00	Reports and discussion Syndicates A	
10.30	Services (cont) Follow-up, service and maintenance (including repairs and replacement), sustainability of service, service delivery system	Abdullah Munish
10.40	Break	
11.00	Syndicates B	
12.30	Lunch	
	Chairman: Rapporteur:	Marc Krizack Kim Reisinger
13.30	Products	
13.35	Designs (including tricycles) <ul style="list-style-type: none"> • User needs • Adult models • Child models • Cushions 	Tone Øderud
	Specific designs:	
14.05	• Motivation	David Constantine
14.15	• Whirlwind	Ralf Hotchkiss
14.25	• HI Philippines, tricycle	Matt McCambridge
14.35	• Wheelchair Foundation	Joel Hodge
14.45	• Free Wheelchair Mission	Michael Bayer
14.55	Discussion	
15.30	Break	
16.00	Postural support including supportive seating	Shona McDonald
16.15	Cushions	Jamie Noon
16.30	The role of user feedback in research and design	Jon Pearlman
16.40	Discussion	
17.00	Close	
17.00-18.30	Cultural Evening: Mobility India	

Wednesday 8th November		
	Chairman: Rapporteur:	Christine Cornick Jon Pearlman
09.00	Reports and discussions Syndicates B	
10.30	Break	
11.00	Syndicates C	
12.30	Lunch	
	Chairman: Rapporteur:	Claude Tardif Sarah Sheldon
13.30	Production	
13.35	Methods of production, test standards, quality control, cost, sustainability	Ray Mines
	Experiences in production facilities:	
14.05	<ul style="list-style-type: none"> • Local: MADE, Uganda 	Fatuma Acan
14.15	<ul style="list-style-type: none"> • Regional: CIR, USA + Worth Trust, India 	Kim Reisinger
14.25	<ul style="list-style-type: none"> • Global: Shanghai Hubang Medical Appliance Co Ltd, China 	Fang Lizhong
14.35	Experiences of strength testing and field trials	Stefan Constantinescu
14.45	Discussion	
15.15	Break	
15.45	Reports and discussion Syndicates C	
17.15	Close	

Thursday 9th November		
09.00	Syndicates D	
10.30	Break	
	Chairman: Rapporteur:	Santiago Castellon David Winters
11.00	Supply and distribution	
11.05	Cost sharing, supply, roles of the stakeholders, distribution	Kylie Mines
	Supply and distribution systems:	
11.35	<ul style="list-style-type: none"> Local community: Disacare, Zambia 	David Mukwasa
11.45	<ul style="list-style-type: none"> Camp approach: ALIMCO, India 	Atul Dubey
11.55	<ul style="list-style-type: none"> Large scale distribution: Wheelchair Foundation, USA 	Joel Hodge
12.05	<ul style="list-style-type: none"> IBR/CBR approach: Interlife, Bangladesh 	Johan Borg
12.15	<ul style="list-style-type: none"> A country-wide view, MoH, Uganda 	Fredrick Semakula
12.25	Discussion	
13.00	Lunch	
	Chairman: David Constantine Rapporteur: Alida Lindsley	
14.00	Reports and discussion Syndicates D	
15.30	Break	
16.00	Syndicates E	
17.30	Close	

Friday 10th November		
	Chairman: Rapporteur:	Harold Shangali Marc Krizack
08.15	Capacity development	
08.20	Organizational capacity building, what is needed to establish wheelchair service provision, building the organization, training personnel, sustainability	Geoff Bardsley
	Organization capacity:	
08.50	<ul style="list-style-type: none"> Albanian Disability Rights Foundation 	Florida Kalemi
09.00	<ul style="list-style-type: none"> APD, Bangalore, India 	VS Basavaraju
	Training:	
09.10	Formal training: TATCOT/Motivation	Yona Ezekiel and Christine Cornick
09.20	Modular approach: Mobility India	Ritu Ghosh
09.30	Skill development in a production context: HI France	Philippe Mazard
09.40	Short courses in assessment & prescription/assembly and fitting	Kylie Mines
09.50	Capacity development of clinical team	Michiel Steenbeek
10.00	Discussion	
10.30	Break	
11.00	Reports and discussion Syndicates E	
12.30	Lunch	
13.30	Syndicates F	
15.00	Break	
	Chairman: Rapporteur:	Geoff Bardsley Christine Cornick
15.30	Guidelines for wheelchair provision	
15.35	Introduction to draft guidelines	Kim Reisinger
16.05	Discussion	
17.00	Close	
20.00	Conference Dinner: Hotel Atria	

Saturday 11th November		
	Chairman: Rapporteurs:	Rob Horvath Norman Jacobs & Sarah Sheldon
09.00	Reports and discussions Syndicates F	
10.30	Break	
11.00	Discussion on identified topics from Syndicates	
12.30	Lunch	
13.30	Recommendations and conclusions	
15.30	Close of Conference	

APPENDIX B: Participants

Acan. Fatuma	Mobility Appliances by Disabled Women Entrepreneurs (MADE) PO Box 9856 Kampala Uganda Email: madeuganda@yahoo.com
Alvarado, Carlos	University of Don Bosco Calle al Plan del Pino Soyapango San Salvador El Salvador Email: kchi_hola@hotmail.com
Armstrong, Bill	Center for International Rehabilitation 211 East Ontario Street Chicago IL 60611 USA Email: warmstrong@cirnetwork.org
Bardsley, Geoff	ISPO NHS Tayside Ninewells Hospital Dundee DD1 9SY UK Email: geoff.bardsley@tuht.scot.nhs.uk
Basavarju, VS	The Association of People with Disability (APD) 6th Cross, Hutchins Road, off Hennur Road Lingarajapuram, St.Thomas Town Post Bangalore 560084 India Email: apdblr@dataone.in / apdblr@gmail.com
Bayer, Michael	Free Wheelchair Mission 2235 Pacific Drive Corona Del Mar CA USA Email: bad2bonemd@adelphia.net
Borg, Johan	WHO Nygatan 6 SE-795 31 Rättvik Sweden Email: johan@propempo.se
Cairo, Alberto	ICRC Ali Abad Orthopaedic Centre Kabul Afghanistan Email: kaboul.kab@icrc.org
Castellon, Santiago	The Polus Centre for Social and Economic Development Nicaragua Email: poluscni@ibw.com.ni

Charowa, Gladys Disabled Women Support Organisation (DWSO)
30 Trinity Road
PO Amby
Greendale
Harare
Zimbabwe
Email: dwso.hre@healthnet.zw

Constantine, David Motivation
Brockley Academy
Brockley Lane
Backwell
Bristol BS48 4AQ
UK
Email: constantine@motivation.org.uk

Constantinescu, Stefan Motivation
110 Beavervalley Drive
Brampton
Ontario L7A 3W6
Canada
Email: constantinescu@motivation.org.uk

Cornick, Christine Motivation Africa
Ward D
Western Cape Rehabilitation Centre
Private Bag X19
Mitchell's Plain
Cape Town 7789
Republic of South Africa
Email: cornick@motivation.org.uk

Curtis, Bruce World Institute on Disability
510 16th Street
Suite 100 Oakland
California 94612
USA
Email: bruce@wid.org

Deshpande, Shivaram Leonard Cheshire International
No 542 9th Cross 3rd Phase
JP Nagar
Bangalore 560078
India
Email: programmesupport@lcisouthasia.org

Dubey, Atul ALIMCO
ALIMCO auxiliary Production Centre,
Plot No. 8, Peeny Plantation, near Jalsoudha
Jalahalli
Bangalore 560013
India
Email: atuldubey05@rediffmail.com

Ezekiel, Yona TATCOT
PO Box 8690
Moshi
Tanzania
Email: yonaez@yahoo.com

Feinberg, Lloyd USAID
Washington
DC 20523
USA
lfeinberg@usaid.gov

Frost, Richard Motivation
Brockley Academy
Brockley Lane
Backwell
Bristol BS48 4AQ
UK
Email: frost@motivation.org.uk

Gall, Fiona Sandy Gall's Afghanistan Appeal (SGAA)
Street 10
Karte She
Kabul
Afghanistan
Email: sgaakabul@yahoo.com

Gallay, Jean- François ICRC
36, Ketai Road
Kunming 650106
PR China
Email: gallayjf@yahoo.com

Ghosh, Ritu Mobility India
1st & 1st 'A' Cross,
JP Nagar 2nd Phase
Bengalooru - 560078
India
Email: e-mail@mobility-india.org

Guang, Chen China Service for Development and Supply of Devices for the
Disabled
No10 North Road Jiaomen
Fengtai District
Beijing 100068
PR China
Email: wuzhangai@sina.com / cg1959@126.com

Hamudenga, Ishmael LOREWO
PO Box 2164
Oshakati
Namibia
Email: lorewo@iway.na

Heim, Sepp ISPO
Im Haggarten 5
D-78337Öhningen
Germany
Email: ot-heim@t-online.de

Hodge, Joel Wheelchair Foundation
3820 Blackhawk Road
Danville
CA 94506
USA
Email: jhodge@wheelchairfoundation.org

Horvath, Rob USAID/LWVF
1300 Pennsylvania Avenue NW
Suite 700 North Tower
Washington
DC
USA
Email: rob@dcofwvf.org

Hotchkiss, Ralf Whirlwind
San Francisco State University Foundation
1600 Holloway Avenue
San Francisco
California 94132
USA
Email: ralfh@sfsu.edu

Ilgan, Venus Disabled People International
Unit 701 Merchant Square Condominium
1386 E. Rodriguez Avenue corner Mabolo Street
1112 Quezon City
Philippines
Email: bbc701@surfshop.net.ph

Ispas, Cristian Motivation Romania Foundation
Sos. Alexandriei
Nr 478
Com. Bragadiru
Ilfov
Romania
Romania
Email: c.ispas@motivation.ro

Jacobs, Norman A ISPO
9 Marchmont Terrace
Glasgow G12 9LS
UK
Email: norman.jacobs@strath.ac.uk

Jensen, J Steen ISPO
Hans Knudsens Plads 1A
DK-2100 Copenhagen Ø
Denmark
Email: steen@ispo.ws

Jinming, He Shanghai Hubang Medical Appliances Co Ltd
No1188 Xiangyang Road
Zhuanqiao Minhang District
Shanghai 201108
PR China
Email: shhubang@vip.sina.com / bjhubang@hotmail.com

Kalemi, Florida Albania Disability Rights Foundation (ADRF)
Rr. Andon Zako Cajupi
Pall e Reja Enil
Kati 3te
Tirana
Albania
Email: adrf@icc.al.eu.org

El Khadiri, Mohammed Amicale Marocaine des Handicapes (AMH)
C/O Royal Air Maroc
77 Boulevard 9 Avril
Quartier Palmier
Casablanca
Morocco
Email: amh@connectcom.net.ma / amicaleshandicapes@menara.ma

Khasnabis, Chapal WHO
20 Avenue Appia
1211 Geneva 27
Switzerland
Email: khasnabisc@who.int

Krizack, Marc Whirlwind Wheelchair International
San Francisco State University
1600 Holloway Avenue
SCI 251
San Francisco
CA 94132
USA
Email: marc@whirlwindwheelchair.org

Lindsley, Alida Whirlwind Wheelchair International
1600 Holloway Avenue
SCI 251
San Francisco
CA 94132
USA
Email: alida@whirlwindwheelchair.org

Lindstrom, Anna ISPO
Swedish Handicap Institute/Swedish Assistive Technology Institute
PO Box 510
SE-162 15 Vallingby
Sweden
Email: anna.lindstrom@hi.se

Lizhong, Fang Shanghai Hubang Medical Appliance Co Ltd
No.1188 Xiangyang Road
Zhuanqiao Minhang District
Shanghai 201108
PR China
Email: bjhubang@hotmail.com / bjhubang@vip.sina.com

Lyimo, John E KCMC
PO Box 3010
Moshi
Tanzania
Email: tatcot@lilinet.co.tz

Madzivanzira, Bigboy Inter-Country Peoples Aid
PO Box cy2008
Causeway
Harare
Zimbabwe
Email: bigazi2001@yahoo.co.uk

Mazard, Philippe HI France
14 Avenue Berthelot
69 361 Lyon
France
Email: pmazard@handicap-international.org

McC Cambridge, Matt HI Philippines
42 Ponce Street
San Lorenzo Village
1223 Makati
Philippines
Email: mccambridge@hotmail.com

McDonald, Shona Shonaquip
3 Tiverton Road
Plumstead
Cape Town
South Africa
Email: shonamma@iafrica.com

Mines, Kylie Motivation
32 Church Street
Port Willunga
South Australia 5173
Email: inwood@motivation.org.uk

Mines, Ray Motivation
32 Church Street
Port Willunga
South Australia 5173
Email: mines@motivation.org.uk

Mukwasa, David Disacare Wheelchair Centre Trust
PO Box 50091
Ridgeway
Lusaka
Zambia
Email: mukwasa@yahoo.com/disacare@zamnet.zm

Munish, Abdullah KCMC
PO BOX 3010
Moshi
Tanzania
Email: abdumasus@yahoo.com

Nanda, Dhabaleswar Handicap International
No10 Zamrudpur Community Centre
Kailash Colony Extension
New Delhi 110048
India
Email: op@hi-sarc.org

Nanda, Rajesh NOPS
Angau Memorial Hospital
POBox 457
Lae
Papua New Guinea
Email: nops@online.net.pg

Ndjambula, Silvanus LOREWU
PO Box 2164
Oshakati
Namibia
Email: lorewo@iway.na

Nganwa, Alice National Institute for Injury Prevention
Injury Control Centre Uganda
PO Box 7072
Kampala Uganda
Email: alicekbn@yahoo.com

Noon, Jamie Noon Design
100 Rio Vista Place #236
Santa Fe
NM 87501
USA
Email: jnoon319@aol.com

Øderud, Tone SINTEF Health Research
PO Box 124
Blindern
N-0314 Oslo
Norway
Email: tone.oderud@sintef.no

Pearlman, Jon University of Pittsbyrgh
7180 Highland Drive
151R-1H
Pittsburgh
Pennsylvania
USA
Email: jlp46@pitt.edu

Radhakrishnan, K Worth Trust
No 48 New Thiruvalem Road
Katpadi - 632 007
Vellore District
Tamilnadu
India
Email: worth@md3.vsnl.net.in / vlr_worth@sancharnet.in

Reisinger, Kim Center for International Rehabilitation (CIR)
211 E. Ontario Street
Suite 300
Chicago
IL 60611
USA
Email: kreisinger@cirnetwork.org

Scheffler, Elsje Western Cape Rehabilitation Centre
P/Bag X19
Mitchell's Plain 7600
South Africa
Email: escheff@pgwc.gov.za

Schoendorfer, Don Free Wheelchair Mission
3940 Irvine Avenue
Irvine
CA
USA
Email: dschoendorfer@cox.net

Schmidt, Karen ISPO
Hans Knudsens Plads 1A
DK-2100 Copenhagen Ø
Denmark
Email: karen@ispo.ws

Seddiq, Asif Sandy Gall's Afghanistan Appeal (SGAA)
Public Health Hospital No 1
Jalalabad City
Afghanistan
Email: sgaakabul@yahoo.com

Seifert, Hubert Christoffel Blindenmission (CBM)/Association for the Physically
Disabled of Kenya (APDK)
PO Box 83988
80100 Mombasa
Kenya
Email: hseifert@africaonline.co.ke

Semakula, Fredrick Ministry of Health
PO Box 7272
Kampala
Uganda
Email: dparmoh@yahoo.co.uk / semma22@madcity.com

Shangali, Harold G ISPO
TATCOT
PO Box 8690
Moshi
Tanzania
Email: ispo@kilinet.co.tz

Shankar, Albina Mobility India
1st & 1st 'A' Cross,
JP Nagar 2nd Phase
Bengalooru - 560078
India
Email: albina44@mobility-india.org

Sheldon, Sarah Motivation
Brockley Academy
Brockley Lane
Backwell
Bristol BS48 4AQ
UK
Email: sheldon@motivation.org.uk

Steenbeek, Michiel Christoffel Blindenmission (CBM)
PO Box 20146
Kampala
Uganda
East Africa
Email: m.steenbeek@africaonline.co.ug

Supavan, Daranee Sirindhorn National Medical Rehabilitation Center
 Ministry of Public Health
 Soi Bumradnaradrool, Tivanon Road
 Mung
 Nonthaburi,
 11000 Thailand
 Email: nudaranee@yahoo.com

Sovann, Keo Jesuit Relief Service
 #96 Street 592
 Tuol Kok
 Phnom Penh
 Cambodia
 Email: camban@online.com.kh / jrscam@forum.org.kh

Tardif, Claude ICRC
 19 avenue de la Paix
 1202 Geneva
 Switzerland
 Email: ctardif@icrc.org

Urseau, Isabelle Handicap International
 14 Avenue Berthelot
 69361 Lyon
 Cedex 07
 France
 Email: iurseau@handicap-international.org

Umarshankar, KS Mobility India
 1st & 1st 'A' Cross,
 JP Nagar 2nd Phase
 Bengalooru - 560078
 India

Vennila, M Mobility India
 1st & 1st 'A' Cross,
 JPNagar 2nd Phase
 Bengalooru - 560078
 India
 Email: therapy@mobility-india.org.

Winters, David Mobility Without Barriers Foundation
 3161 Baldwin Road
 Hinesburg
 Vermont 05461
 USA
 Email: dwm@mobilityfoundation.org

Winters, Gary Latter Day Saint Charities
 50 East North Temple
 Salt Lake City
 UT 84150
 USA
 Email: wintersgl@ldschurch.org

APPENDIX C: Glossary

ADRF	Albanian Disability Rights Foundation
AMH	Amicale Marocaine des Handicapes
APD	Association of People with Disability
APDK	Association for the Physically Disabled of Kenya
CBO	Community Based Organization
CBR	Community Based Rehabilitation
CDPF	China Disabled Persons Federation
CIR	Center for International Rehabilitation
DFID	Department for International Development
DPI	Disabled Peoples' International
DPO	Disabled People's Organization
DWSO	Disabled Women's Support Organization
EC	European Community
EU	European Union
FWM	Free Wheelchair Mission
HI	Handicap International
ICRC	International Committee of the Red Cross
INGO	International Non-Governmental Organization
ISPO	International Society for Prothetists and Orthotists
ISO	International Organization for Standardization
KASI	Kilimanjaro Association of Spinally Injured
KCMC	Kilimanjaro Christian Medical Centre
LDS	Latter Days Saints
LOREWO	Low Cost Rehabilitation Workshop
LWVF	Leahy War Victims Fund (USAID)
MADE	Mobility Equipment by Women Entrepreneurs
MDG	Millennium Development Goals
MI	Mobility India
NAD	Norwegian Association of the Disabled
NOPS	National Orthotic and Prosthetic Service
OT	Occupational therapist
P&O	Prosthetics & Orthotics
PAWBA	Pan African Wheelchair Builders Association
PGT	Peer Group Training
PNG	Papua New Guinea
PRSP	Poverty Reduction Strategy Paper
PT	Physiotherapist
QUAPAZ	Quadriplegic and Paraplegic Association of Zimbabwe

SCI	Spinal Cord Injury
SGAA	Sandy Gall Afghanistan Appeal
SIA	Spinal Injuries Association
SINTEF	Foundation for Scientific & Industrial Research at the Norwegian Institute of Technology
TATCOT	Tanzania Training Centre for Orthopaedic Technologists
UDB	University of Don Bosco
UN	United Nations
USAID	United States Agency for International Development
WCRC	Western Cape Rehabilitation Centre
WF	Wheelchair Foundation
WHO	World Health Organization
WID	World Institute on Disability
WM	Worldmade
WTTC	Wheelchair Technologist Training Course
WWI	Whirlwind Wheelchairs International