

Core Medical Equipment



WHO/HSS/EHT/DIM/11.03

© World Health Organization 2011

All rights reserved. World Health Organization, 20 Avenue Appia, 1211 Geneva 27, Switzerland (tel.: +41 22 791 3264; fax: +41 22 791 4857). Requests for permission to reproduce or translate WHO publications – whether for sale or for noncommercial distribution – should be addressed to WHO Press, at the above address (fax: +41 22 791 4806; e-mail: permissions@who.int).

The designations employed and the presentation of the material in this publication do not imply the expression of any opinion whatsoever on the part of the World Health Organization concerning the legal status of any country, territory, city or area or of its authorities, or concerning the delimitation of its frontiers or boundaries. Dotted lines on maps represent approximate border lines for which there may not yet be full agreement.

The mention of specific companies or of certain manufacturers' products does not imply that they are endorsed or recommended by the World Health Organization in preference to others of a similar nature that are not mentioned.

Errors and omissions excepted, the names of proprietary products are distinguished by initial capital letters.

All reasonable precautions have been taken by the World Health Organization to verify the information contained in this publication. However, the published material is being distributed without warranty of any kind, either expressed or implied. The responsibility for the interpretation and use of the material lies with the reader. In no event shall the World Health Organization be liable for damages arising from its use.

Contents

Analyzer, Laboratory, Hematology, Blood Grouping, Automated

Anesthesia Unit

Apnea Monitors

Aspirator

Auditory Function Screening Device, Newborn

Bilirubinometer

Blood Gas/pH/Chemistry Point of Care Analyzer

Blood pressure monitor

Bronchoscope

Cataract Extraction Units

Clinical Chemistry Analyzer

Colonoscope

Cryosurgical Unit

Cytometer

Defibrillator, External, Automated; Semiautomated

Defibrillator, External, Manual

Densitometer, Bone

Electrocardiograph, ECG

Electrosurgical Unit

Fetal Heart Detector, Ultrasonic

Fetal monitor

Glucose Analyzer

Hematology Point of Care Analyzer

Hemodialysis Unit

Immunoassay Analyzer

Incubator, Infant

Laser, CO2
Laser, Ophthalmic
Mammography unit
Monitor, Bedside, Electroencephalography
Monitor, Central Station
Monitoring System, Physiologic
Monitor, Telemetric, Physiologic
Peritoneal Dialysis Unit
Pulmonary function analyzer
Radiographic, Fluoroscopic System
Radiotherapy Planning System
Radiotherapy Systems
Remote-afterloading brachytherapy system
Scanning System, CT
Scanning System, Magnetic Resonance Imaging, Full-Body
Scanning System, Ultrasonic
Transcutaneous Blood Gas Monitor
Ventilator, Intensive Care
Ventilator, Intensive Care, Neonatal/Pediatric
Ventilator, Portable
Videoconferencing system, Telemedicine
Warming Unit, Radiant, Infant
Whole Blood Coagulation Analyzer



Core medical equipment

“Core medical equipment” refers here to technologies that are commonly considered as important or necessary for specific preventive, diagnostic, treatment or rehabilitation procedures carried out in most health care facilities.

Today, there are more than 10,000 types of medical devices available. The selection of appropriate medical equipment always depends on local, regional or national requirements; factors to consider include the type of health facility where the devices are to be used, the health work force available and the burden of disease experienced in the specific catchment area. It is therefore impossible to make a list of core medical equipment which would be exhaustive and/or universally applicable.

With that being said, we have reproduced hereafter a set of core medical equipment fact sheets which have been issued by the ECRI Institute and the GMDN Agency, with a view to raising stakeholders’ awareness about their existence and their functionality.

Each fact sheet displays a type of medical equipment, the health problems addressed by the device, the operation procedures, its typical size, weight and price range, and infrastructure requirements for effective and safe use. Technologies are placed into context of existing nomenclature systems; they are not specific to any brand, model or vendor. The equipment is classified under the following categories: therapeutic, diagnostic, chronic disease and child health.

The WHO Department of Essential Health Technologies is planning to continuously update the list of core medical equipment and make it publicly available on the WHO website for information purposes, subject to the disclaimers here below.

Disclaimer

WHO has not reviewed the safety, efficacy, quality, applicability, or cost acceptability of any of the technologies referred to hereafter. Therefore, inclusion of the aforesaid fact sheets herein does not constitute a warranty of the fitness of any technology or of any resulting product and any future development thereof, for a particular purpose. Besides, the responsibility for the quality, safety and efficacy of each technology or each resulting product remains with its developer, owner and/or manufacturer.

WHO will not be held to endorse nor to recommend any technology or any resulting product thereof, as such or in preference to others of a similar nature.

WHO does not warrant or represent that the use of the technologies or the resulting products thereof is, or will be, in accordance with the national laws and regulations of any country, including but not limited to patent laws. WHO disclaims any and all liability and responsibility whatsoever for any injury, death, loss, damage or other prejudice of any kind whatsoever that may arise as a result of, or in connection with, the procurement, distribution and/or use of any technology referred to hereafter, or of any resulting product and any future development thereof.

Developers, owners and/or manufacturers of the technologies or resulting products thereof shall not, in any statement of an advertising, commercial and/or promotional nature, refer to the inclusion of their technologies in this publication. In no case shall the latter use the WHO name and/or the emblem, or any abbreviation thereof, in relation to their business or otherwise.



Analyzer, Laboratory, Hematology, Blood Grouping, Automated

UMDNS

16817 Analyzers, Laboratory, Hematology, Blood Grouping, Automated

GMDN

56712 ABO/Rh(D) blood grouping analyser IVD, automated

Other common names:

Blood type analyzer, ABO blood typing system, ABO blood typing system; Blood Grouping System

Health problem addressed

Blood grouping systems perform basic blood processing tests that include ABO grouping and subgrouping, Rh and other red cell phenotyping, and antibody detection. These tests determine factors that can cause transfusion reactions such as red cell hemolysis, anaphylaxis, and other immunologic and nonimmunologic effects.

Product description

Floor-standing or benchtop device includes a rack or tray onto which patient blood sample tubes are loaded; the samples are mixed with reagents to determine blood type and the results are displayed on a monitor; cabinets or compartments store reagent vessels; a monitor, keyboard, mouse, and printer (or entire computer) may be connected for programming, data entry, and to view and print testing results.

Principles of operation

Blood tube containing ethylenediamine-tetraacetic acid (EDTA) anticoagulant is loaded onto the analyzer, and the operator usually centrifuges them to separate the RBCs from the plasma. Automated analyzers typically resuspend the RBCs in saline and load the diluted samples onto microplates to which reagents (known antisera) have been added. Blood group identity occurs when the known antiserum, containing antibodies, clumps (agglutinates) RBCs that have a corresponding antigen. Bar-code labels provides a means of sample tracking.

Operating steps

Technicians load tubes into the sample tray and keep reagents filled; tests are programmed either via a touchscreen panel on the instrument, a computer, or the required test information is on the tube's printed bar code.

Reported problems

Operators should be aware of the risk of exposure to potentially infectious bloodborne pathogens during testing procedures and should use universal precautions, including wearing gloves, face shields or masks, and gowns.

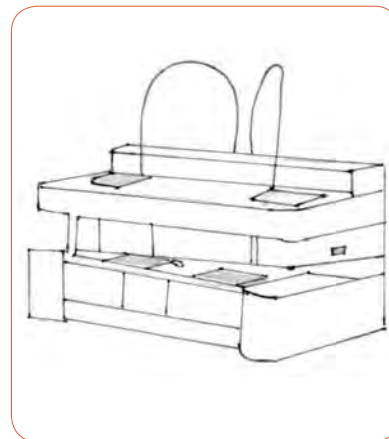

Use and maintenance

User(s): Laboratory technician

Maintenance: Biomedical or clinical engineer

Training: Initial training by manufacturer and manuals

Environment of use

Settings of use: Hospital, blood bank, clinical laboratory

Requirements: Line power, water supply, benchtop or floor space, biohazard disposal

Product specifications

Approx. dimensions (mm): 1,000 x 1,750 x 900

Approx. weight (kg): 50-500

Consumables: Reagents, blood tubes

Price range (USD): 115,000 - 225,000

Typical product life time (years): 5-7

Shelf life (consumables): EDTA: 1 year

Types and variations

Benchtop or floor-standing



Anesthesia Unit

UMDNS

10134 Anesthesia Units

GMDN

47769 Anaesthesia unit, mobile

Other common names:

Anesthesia machines; Anaesthesia apparatus; Gas-machine, anesthesia

Health problem addressed

Anesthesia units dispense a mixture of gases and vapors and vary the proportions to control a patient's level of consciousness and/or analgesia during surgical procedures.

Product description

An anesthesia system comprises of a gas delivery platform, a data analysis and distribution system, and physiologic and multigas monitors (optional in most units), which indicate levels and variations of several physiologic variables and parameters associated with cardiopulmonary function and/or gas and agent concentrations in breathed-gas mixtures. Manufacturers typically offer a minimum combination of monitors, alarms, and other features that customers must purchase to meet standards and ensure patient safety.

Principles of operation

Because O₂ and N₂O are used in large quantities, they are usually drawn from the hospital's central gas supplies. Vaporizers add a controlled amount of anesthetic vapor to the gas mixture. An automatic ventilator is generally used to mechanically deliver breaths to the patient. The ventilator forces the anesthesia gas mixture into the patient's breathing circuit and lungs and, in a circle breathing system, receives exhaled breath from the patient as well as fresh gas. A scavenging system captures and exhausts waste gases to minimize the exposure of the operating room staff to harmful anesthetic agents. Scavenging systems remove gas by a vacuum, a passive exhaust system, or both.

Operating steps

A mask is placed over the nose and mouth. The anesthesia unit dispenses a mixture of gases and vapors and varies the proportions to control a patient's level of consciousness and/or analgesia during surgical procedures. The patient is anesthetized by inspiring a mixture of O₂, the vapor of a volatile liquid halogenated hydrocarbon anesthetic, and, if necessary, N₂O and other gases.

Reported problems

One of the greatest dangers of anesthesia is hypoxia, which can result in brain damage or death, though the administration of concentrated O₂ (100%) may be toxic. Gas with excessive CO₂ concentration, an inadequate amount of anesthetic agent, or dangerously high pressure may cause hypoventilation, compromised cardiac output, pneumothorax, and asphyxiation. Contamination of the anesthesia breathing circuit may lead to nosocomial infections.

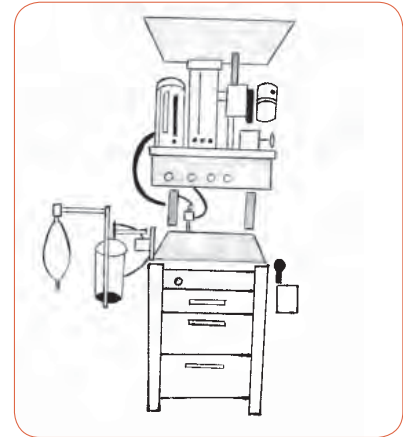

Use and maintenance

User(s): Anesthesiologist, nurse anesthetist, medical staff

Maintenance: Biomedical or clinical engineer/technician, medical staff, manufacturer/servicer

Training: Initial training by manufacturer, operator's manuals, user's guide, some manufacturers offer offsite training or remote training

Environment of use

Settings of use: Hospital (surgery), ambulatory surgery centers

Requirements: Uninterruptible power source, O₂ fail-safe and hypoxic mixture fail-safe systems, gas cylinder yokes for O₂ if central supplies fail, internal battery (for units with automatic ventilators) capable of powering the unit for at least 30 minutes

Product specifications

Approx. dimensions (mm): 1,500 x 700 x 700

Approx. weight (kg): 130

Consumables: Anesthetic agents, tubing, masks

Price range (USD): 5,000 - 100,000

Typical product life time (years): 8-10

Shelf life (consumables): Variable

Types and variations

Cart mounted, ceiling mounted, wall mounted, mobile



Apnea Monitors

UMDNS

12575 Monitors, Bedside, Respiration, Apnea

GMDN

35194 Respiratory apnoea monitoring system

Other common names:

Cardiorespiratory monitors; Monitor, recording, apnoea

Health problem addressed

Apnea monitors detect the cessation of breathing (apnea) in infants and adults who are at risk of respiratory failure and alert the parent or attendant to the condition. Some prolonged respiratory pauses result in low oxygen concentration levels in the body, which can lead to irreversible brain damage and, if prolonged, death.

Product description

The components of apnea monitors depend specifically on the type. However, in general they are composed of a set of sensors which obtain the information of different physiological parameters. This information is passed to a micro computer system, which analyses the sensors' information and determines if apnea is occurring.

Principles of operation

Monitors that use impedance pneumography detect small changes in electrical impedance as air enters and leaves the lungs and as the blood volume changes in the thoracic cavity. Mattress-type motion sensors typically monitor changes in the capacitance or resistance of a mattress transducer. Pneumatic abdominal sensors also detect breaths as changes in pressure. More direct methods of respiration detection monitor the airflow into and out of the lungs; these include thermistors, proximal airway pressure sensors, and carbon dioxide (CO₂) sensors.

Operating steps

The apnea monitor is attached to the patient using appropriate sensor for the measurement technique (e.g., mattress motion sensor, pneumatic abdominal sensors, thermistors, proximal airway pressure sensors, carbon dioxide (CO₂) sensors, cannula). Once connected, as the patient breathes, the unit monitors different body parameters. If an alarm sounds, the operator must attend the patient immediately.

Reported problems

Apnea monitors may fail to alarm during an episode because they sense artifact (artifacts include vibrations, heart activity, patient movement). Electromagnetic emissions from electronic devices (other electronics or equipment) can also cause interference, possibly leading to false breath and heartbeat detection. Impedance pneumographs are more subject to cardiovascular artifact. Misinterpreting impedance changes because of heartbeats perceived as breaths frequent when instrument sensitivity is not adjusted.

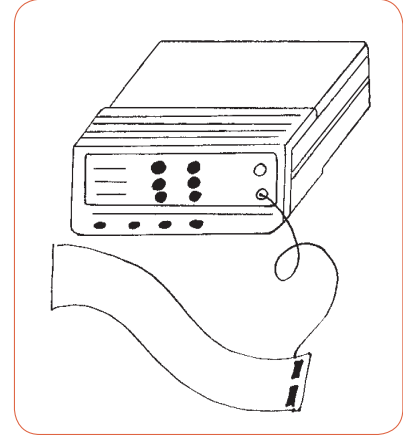

Use and maintenance

User(s): Nurse, medical staff, home care providers

Maintenance: Biomedical or clinical engineer/technician, medical staff, manufacturer/servicer

Training: Initial training by manufacturer, operator's manuals, user's guide

Environment of use

Settings of use: Hospital, home, ambulatory care center, nursery

Requirements: Uninterruptible power source, battery backup

Product specifications

Approx. dimensions (mm): 150 x 120 x 120

Approx. weight (kg): 0.75

Consumables: Batteries, cables, electrodes/sensors

Price range (USD): 200 - 5,000

Typical product life time (years): 8

Shelf life (consumables): NA

Types and variations

Stand-alone, modular



Aspirator

UMDNS

10217 Aspirators, Surgical

GMDN

10217 Surgical suction system

Other common names:

Suction unit, suction pump, evacuator, vacuum pump

Health problem addressed

Most surgical procedures require suctioning to remove blood, gas, tissue, or other foreign materials and irrigating fluids that accumulate in the operative field and obstruct the surgeon's view. Portable or mobile aspirators can be used if there is no central vacuum system or if suctioning is required in areas that do not have vacuum inlets.

Product description

Surgical aspirators consist of a line-powered vacuum pump, a vacuum regulator and gauge, a collection canister, and an optional bacterial filter. Plastic tubing connects these components, completing an open-ended system that continuously draws tissue debris and fluid from the surgical field to the collection canister. The gauge allows the user to set a safe limit for suctioning, to assess the performance of the vacuum pump, and to detect leaks or blockages. Units are either portable or mounted on a stand or cart for mobility.

Principles of operation

Various pump configurations include rotary-vane, diaphragm, and piston. Each mechanism alternately increases and decreases the vacuum and/or chamber volume, creating suction. Air is drawn from the external tubing into the chamber, drawing aspirate into a collection canister. Most surgical aspirators have an overflow-protection assembly that prevents fluid from overflowing into the pump and valves.

Operating steps

Operator powers on unit and selects appropriate suction level and inserts suction tip into patient cavity. Collection canisters should be monitored and emptied if they come close to capacity.

Reported problems

Suction regulators must be accurate; suction levels that are too high can cause tissue damage. Some models operate at high noise levels that can eclipse the volume of alarms for other devices. A pump containing aspirated fluid can be a source of contamination. Changing or cleaning the suction tip during surgeries or other use can help reduce infection risk. Operators should follow universal precautions, including wearing gloves, face shields or masks, and gowns.

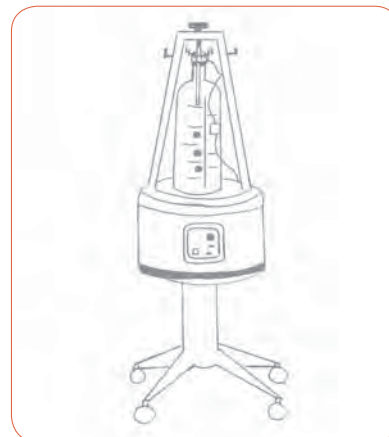

Use and maintenance

User(s): Surgeons, assisting surgeons, nurses, respiratory therapists, other medical staff

Maintenance: Biomedical or clinical engineer

Training: Initial training by manufacturer and manuals

Environment of use

Settings of use: OR, patient bedside, home, long-term care, ER

Requirements: Line power, biohazard disposal

Product specifications

Approx. dimensions (mm): 300 x 400 x 800

Approx. weight (kg): 5-25

Consumables: Tubing, collection canisters, liners, batteries

Price range (USD): 160 - 5,000

Typical product life time (years): 8-10

Shelf life (consumables): Rubber tubing: 10 yrs

Types and variations

Portable (sometimes considered a separate category of emergency aspirators) or on a cart; disposable or reusable canisters; waterproof designs. The three types of pumps used in surgical aspirators are rotary vane, diaphragm, and cylinder piston



Auditory Function Screening Device, Newborn

UMDNS

20167 Auditory Function Screening Devices, Newborn

GMDN

58019 Otoacoustic emission system, battery-powered

Other common names:

Automated Hearing Screening Devices; Newborn Auditory Function Screening Devices; Newborn Hearing Screening Devices; Universal Newborn Hearing Screening Systems

Health problem addressed

Devices that allow hearing impairments to be detected quickly so that any speech and language deficiencies can be addressed with early intervention programs. If hearing impairments are not detected early in life, social, emotional, and intellectual development (e.g., speech and language acquisition, academics) can be affected. Permanent childhood hearing loss is the most common defect that can be diagnosed at birth.

Product description

Devices consisting of a main testing system with a display screen and ear tips, earmuffs, or electrodes; the unit can be table- or cart-mounted.

Principles of operation

Once the ear probe(s) or electrodes are in place, infant screening tests are performed using either auditory brainstem response (ABR) or otoacoustic emissions (OAEs). ABR, an electrophysiologic assessment, is used to measure the auditory system's response to sound. A soft click (usually 35 to 50 decibels [dB]) is presented to the ear(s) via earphones or probes. OAE is a screening method based on measuring the integrity of the outer hair cells in the cochlea (inner ear). A soft click (usually 25 dB) is presented, and a small microphone measures the acoustic response that is returned from the baby's ear via a probe in the ear canal.

Operating steps

For OAE screening the screener places a miniature earphone and microphone in the infant's ear. Sounds are played, and a response is measured. If the infant hears normally, an echo is reflected into the ear canal and is measured by the microphone. If there is no hearing loss, no echo can be measured. For ABR testing, sounds are played into an infant's ears. Electrodes are placed on the baby's head to detect responses. This measures how the hearing nerve responds to sounds and can identify infants with a hearing loss.

Reported problems

Users may experience difficulty inserting probes into the ear canal. Improper probe fitting can increase the referral rate. Proper insertion technique is easily learned, but the operator usually needs some instruction. Some units have alarms for improper probe placement. Proper earphone placement and electrode impedances during setup and continuous monitoring during testing are important. Obstruction in earphones (tips or muffs) or myogenic interferences should be monitored during automatic checks.



Use and maintenance

User(s): Audiologist; medical staff

Maintenance: Medical staff; technician; biomedical or clinical engineer

Training: Initial training by manufacturer and manuals

Environment of use

Settings of use: Hospital; clinic

Requirements: Stable power source

Product specifications

Approx. dimensions (mm): 195 x 70 x 30

Approx. weight (kg): 0.25

Consumables: NA

Price range (USD): 2,995 - 22,000

Typical product life time (years): 7

Shelf life (consumables): NA

Types and variations

Units may be table- or cart-mounted.



Bilirubinometer

UMDNS

15109 Bilirubinometers
16166 Bilirubinometers, Cutaneous

GMDN

47988 Bilirubinometer
16166 Cutaneous bilirubinometer

Other common names:

Analyzers, Bilirubin; Bilirubin Analyzers; Jaundice Meters; Indirect Bilirubinometers

Health problem addressed

In healthy full-term neonates, bilirubin can rise to peak levels of 5 to 13 mg/dL between the second and fifth days of life before decreasing to normal levels between the fifth and seventh days. This produces jaundice, a yellowish discoloration of the skin, eyes, and mucous membranes. Monitoring bilirubin concentration is also important in children and in adults where elevated levels may indicate a pre-hepatic, hepatic, or post-hepatic metabolic disorder.

Product description

These devices come in a variety of physical configurations. They may be relatively small, single-purpose hand-held instruments that are simple to operate and are designed to measure the concentration of bilirubin in the blood. They are often located in neonatal intensive care units for rapid on-site bilirubin analysis, which is essential for determining a proper treatment method. Bilirubinometers may also be configured as larger benchtop analyzers or stand-alone units.

Principles of operation

Bilirubin concentrations are determined either by whole blood or serum analysis using spectrophotometric methods or by skin-reflectance measurements. The three methods of spectrophotometric analysis are the direct spectrophotometric method, the Malloy-Evelyn method, and the Jendrassik-Grof method.

Operating steps

Blood samples are required for spectrophotometric analysis. The analysis technique depends on both the type or types of bilirubin being measured and the age of the patient (neonate versus child or adult). Cutaneous bilirubinometers do not require a blood sample. A light-emitting sensor is placed on the infant's skin (optimally on the forehead or sternum). The reflected light is split into two beams by a dichroic mirror, and wavelengths of 455 nm and 575 nm are measured by optical detectors.

Reported problems

Rapid changes in hydration (body water content) during therapy can cause fluctuations in blood bilirubin concentrations, making assay results uncertain. Photo-oxidation (light-induced breakdown) of bilirubin occurs if samples are exposed to light for more than a few hours. Therefore, blood samples should be protected from exposure to light.

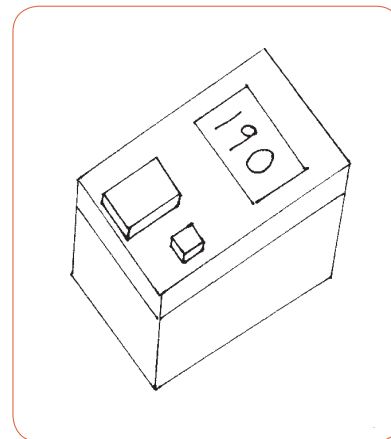

Use and maintenance

User(s): Operator, medical staff

Maintenance: Medical staff; technician; biomedical or clinical engineer

Training: Initial training by manufacturer and manuals

Environment of use

Settings of use: Hospital; clinic

Requirements: Stable power source

Product specifications

Approx. dimensions (mm): 110 x 150 x 200

Approx. weight (kg): 3.4

Consumables: NA

Price range (USD): 3,100 - 7,000

Typical product life time (years): 6 to 8

Shelf life (consumables): NA

Types and variations

Benchtop; stand-alone; handheld



Blood Gas/pH/Chemistry Point of Care Analyzer

UMDNS

18853 Analyzers, Point-of-Care, Whole Blood, Gas/pH/
Electrolyte/Metabolite

GMDN

56661 Blood gas analyser IVD, automated

Other common names:

POC Analyzer, blood gas analyzer

Health problem addressed

Analyzers used to measure blood gas, pH, electrolytes, and some metabolites in whole blood specimens. They can measure pH, partial pressure of carbon dioxide and oxygen, and concentrations of many ions (sodium, potassium, chloride, bicarbonate) and metabolites (calcium, magnesium, glucose, lactate). They are also used to determine abnormal metabolite and/or electrolyte levels in blood and the patient's acid-base balance and levels of oxygen/carbon dioxide exchange.

Product description

Handheld device or benchtop device, sometimes placed on a cart, with a display (usually LCD), a keypad to enter information, and a slot to insert a test strip or sample tube. Some models may have alarms, memory functions, touchpens, USB ports to transfer data to a computer, and/or a small storage compartment for reagents.

Principles of operation

Blood gas/pH analyzers use electrodes to determine pH, partial pressure of carbon dioxide, and partial pressure of oxygen in the blood. Chemistry analyzers use a dry reagent pad system in which a filter pad impregnated with all reagents required for a particular reaction is placed on a thin plastic strip. Electrolyte analyzers use ion-selective electrode (ISE) methodology in which measurements of the ion activity in the solution are made potentiometrically using an external reference electrode and an ISE containing an internal reference electrode.

Operating steps

Whole blood samples are placed in tubes, on reaction cuvettes, or on test strips, and loaded into the analyzer. The operator may select the tests being performed on the sample using a keypad or connected computer.

Reported problems

Operators should be aware of the risk of exposure to potentially infectious bloodborne pathogens during testing procedures and should use universal precautions, including wearing gloves, face shields or masks, and gowns.



Use and maintenance

User(s): Medical staff

Maintenance: Laboratory technician;
biomedical or clinical engineer

Training: Initial training by manufacturer and manuals

Environment of use

Settings of use: Hospital, patient bedside,
physician office, clinical laboratory, home

Requirements: Battery-operated handheld devices do not have special settings requirements; benchtop units require line power

Product specifications

Approx. dimensions (mm): 100 x 300 x 400

Approx. weight (kg): 1-5 for handheld units;
15-25 for benchtop units

Consumables: Reagent cartridges or test strips, batteries

Price range (USD): 150 - 165,000

Typical product life time (years): 4-6

Shelf life (consumables): Reagents: 1-2 years

Types and variations

Handheld, portable, benchtop



Blood pressure monitor

UMDNS

18325 Sphygmomanometers, Electronic, Automatic,
18326 Auscultatory
25209 Sphygmomanometers, Electronic, Automatic,
Oscillometric
Monitors, Physiologic, Vital Signs

GMDN

16173 Automatic-inflation electronic
sphygmomanometer, non-portable

Other common names:

Vital signs monitoring units; noninvasive blood pressure (NIBP) monitors; auscultatory sphygmomanometers; oscillometric sphygmomanometers; oscillotonometers, spot check monitors; spot checking; Recorder, sphygmomanometer, automatic

Health problem addressed

NIBP is an essential indicator of physiologic condition. As one of the most frequently used diagnostic tests, it indicates changes in blood volume, the pumping efficiency of the heart, and the resistance of the peripheral vasculature. Vital signs monitors are used to measure basic physiologic parameters so that clinicians can be informed of changes in a patient's condition. Depending on their configuration, these units can measure and display numerical data for NIBP, oxygen saturation, and temperature.

Product description

Automatic electronic sphygmomanometers noninvasively measure and display a patient's arterial blood pressure. The main unit includes controls and a display; it also includes appropriate attached cuffs, probes, and sensors that make possible sequential and/or simultaneous measurements of the parameters. Some of the NIBP monitors can be used as vital sign monitors with the real-time measuring and display of two or more of the vital signs. These monitors typically consist of portable or mobile electronic units. The monitor may be connected to the line and/or powered by internal batteries. Many devices may also perform continuous monitoring during transportation or at the bedside. Vital signs physiologic monitors are intended mainly for periodic automated measuring of the parameters of one or more patients.

Principles of operation

Automatic electronic sphygmomanometers (NIBP monitors) measure by the use of sound and detection of blood sound turbulence (Korotkoff sounds). A microphone positioned against an artery compressed by the device cuff detects the Korotkoff sounds, enabling the unit to directly determine systolic and diastolic values blood pressure values. NIBP is usually measured using cuffs and either auscultatory or oscillometric techniques. The measurement of temperature is typically accomplished using an intraoral sensor, and SpO₂ is determined using pulse oximetry sensors. These monitors typically consist of portable or mobile electronic units that facilitate movement from one location to other; the monitor may be connected to the line and/or powered by internal batteries.

Operating steps

The cuffs, probes, and sensors are attached to the patient, and then the monitor will begin taking intermittent or continuous measurements as selected by the clinician. The devices may remain at a patient's bedside or can be transported by a caregiver for vital signs spot checking throughout a care area. Alarms (e.g., for high blood pressure or low oxygen saturation) can typically be set by caregivers and can be manually temporarily silenced.

Reported problems

Problems associated with monitors are often user-related. Poor cuff placement or sensor preparation and attachment are most commonly reported. Cables and lead wires should be periodically inspected for breaks and cracks. Automatic



electronic sphygmomanometry and pulse oximeters may have the inability to effectively monitor patients with certain conditions (e.g., tremors, convulsions, abnormal heart rhythms, low blood pressure)

Use and maintenance

User(s): Physicians, nurses, other medical staff

Maintenance: Biomedical or clinical engineer/technician, medical staff, manufacturer/servicer

Training: Initial training by manufacturer, operator's manuals, user's guide

Environment of use

Settings of use: Hospital (all areas), ambulatory surgery centers

Requirements: Battery, uninterruptible power source, appropriate cuffs/sensors

Product specifications

Approx. dimensions (mm): 100 x 150 x 200

Approx. weight (kg): 3

Consumables: Batteries, cables, sensors/electrodes, cuffs

Price range (USD): 580 - 4,500

Typical product life time (years): 10

Shelf life (consumables): NA

Types and variations

Roll stand, portable, pole or bed mounts



Bronchoscope

UMDNS

15073	Bronchoscopes, Flexible
17662	Bronchoscopes, Flexible, Video
15074	Bronchoscopes, Rigid

GMDN

35461	Flexible fiberoptic bronchoscope
44921	Flexible ultrasonic bronchoscope
17662	Flexible video bronchoscope
15074	Rigid bronchoscope

Other common names:

Bronchial Endoscopes; Video Bronchoscopes

Health problem addressed

Devices that are introduced at the nose or mouth to observe distal branches of the bronchi. Through working channels in the bronchoscope, the physician can sample lung tissue (e.g., when pulmonary malignancies are suspected), instill radiographic media for bronchographic studies, perform laser therapy, remove foreign objects, suction sputum for microbiological culturing, insert catheters, and perform difficult intubations.

Product description

These devices consist of a proximal housing, a flexible insertion tube ranging from 0.5 to 7.0 mm in diameter, and an “umbilical cord” connecting the light source and the proximal housing. The proximal housing, which is designed to be held in one hand, typically includes the eyepiece (fiberoptic models only), controls for distal tip (bending section) angulation and suction, and the working channel port.

Principles of operation

The bronchoscope (either flexible or rigid) is inserted into the airways, usually through the mouth or nose. Sometimes the bronchoscope is inserted via a tracheostomy. Rigid bronchoscopes are used for the removal of foreign bodies while flexible video bronchoscopes are intended to provide images of a patient’s airways and lungs. Images provided by the bronchoscope can be focused by adjusting the ocular on the scope’s proximal housing. A video bronchoscope uses a charge-coupled device (CCD) located at the distal tip of the scope to sense and transmit images, replacing the image guide and eyepiece. These images can then be recorded, printed, stored on digital media, or transmitted to another location for simultaneous viewing.

Operating steps

If a rigid bronchoscope is used, the patient will require anesthesia before insertion into the airway via either the mouth or nose. For procedures using flexible bronchoscopes, the patient’s throat will be numbed and the tube is then inserted into the airway via either the mouth or nose. Video bronchoscopes are also inserted via the mouth or nose, but have the benefit of permitting the physician to see the patient’s airways on an external monitor, rather than through an eyepiece.

Reported problems

Despite the remote location of the light source, some of the heat produced by the lamp is transmitted to the tip of the bronchoscope. Bronchospasms and abnormal heartbeats may occur in patients with respiratory or cardiac disorders. Bronchial perforations can occur if biopsy brushes or other instruments are forced out of the bronchoscope’s distal end and meet resistance. Other complications may include loss of biopsy brushes, or breakage of biopsy forceps.

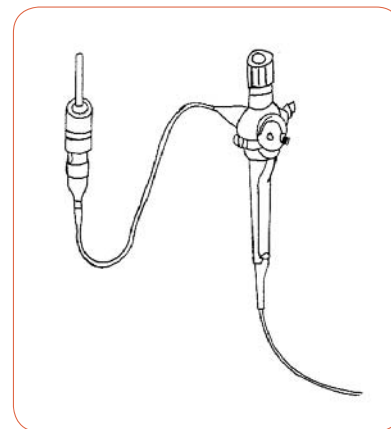

Use and maintenance

User(s): Dedicated operator

Maintenance: Medical staff; technician; biomedical or clinical engineer; central sterile processing technician for cleaning and disinfecting

Training: Supervised training with experienced users

Environment of use

Settings of use: Endoscopy suite; operating room; intensive care unit (rarely)

Requirements: Stable power source; access to anesthesia and patient monitoring; oxygen and suction should be available; access to PACS or x-ray viewbox; bronchoscopy suite should have direct external ventilation, HEPA filtration

Product specifications

Approx. dimensions (mm): 600

Approx. weight (kg): 2.3

Consumables: NA

Price range (USD): 3,560 - 53,120

Typical product life time (years): 4 to 5

Shelf life (consumables): NA

Types and variations

Flexible; flexible video; rigid



Cataract Extraction Units

UMDNS

17596 Phacoemulsification Units, Cataract Extraction
11068 Cryosurgical Units, Ophthalmic

GMDN

45071 Phacoemulsification system generator
11068 Ophthalmic cryosurgical system, mechanical

Other common names:

Phacoemulsification Units; Phacoemulsifiers; Cryoextractors; Cryosurgical Systems; Erysiphakes; Extractors, Cataract; Fragmatomes; Cryophthalmic unit; unit, cryotherapy, ophthalmic

Health problem addressed

Devices intended to break up and remove cataractous lenses of the eye. Cataracts inhibit the transmission of light to the retina and cause a painless blurring of vision. Cataracts are caused by changes in the chemical composition of the lens associated with many factors including age, environment, drugs, systemic diseases, traumatic eye injuries, certain diseases of the eye, and genetic or birth defects.

Product description

These units consist of a hollow probe (i.e., a phaco probe) that includes an irrigation sleeve, an oscillating tip that converts electric energy into ultrasonic waves, and a channel for aspiration of lens fragments; the units also include a vacuum pump and controls for the output levels, irrigation rate, and mode of operation. CSUs (cryosurgical units) apply a refrigerant (cryogen) to withdraw heat from target tissue either through direct application or indirectly through contact with a cryogen-cooled probe.

Principles of operation

These devices are intended to remove cataractous lenses by the insertion of a probe that cuts and emulsifies the lenses using ultrasonic waves (phacoemulsification).

Operating steps

An incision is made to gain access to the eye's anterior chamber. A viscoelastic material is then infused to deepen the anterior chamber. After removing the anterior lens capsule and hydrodissecting the lens to separate it from the cortex and capsule, the surgeon inserts a phacoemulsification probe tip. The probe tip oscillates rapidly creating ultrasonic waves that cut tissue. The cataractous lens is emulsified and the lens fragments are then aspirated from the eye through the hollow tip of the phacoemulsifier.

Reported problems

Thermal lesions to the sclera and cornea due to insufficient irrigation and aspiration flow; metal fragments being left in patients' eyes following phacoemulsification and of phacoemulsification units failing to vacuum; torn posterior capsule due to high vacuum; postoperative endophthalmitis resulting from bacterial contamination; surgically induced astigmatism; corneal burns.

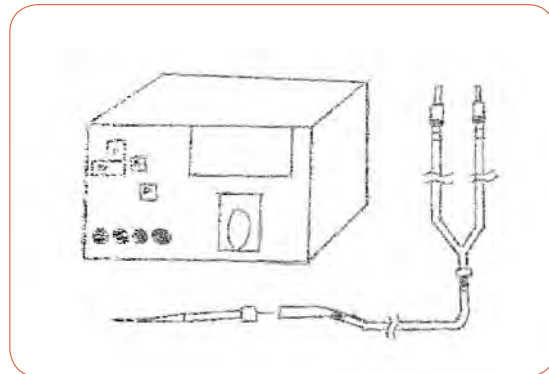

Use and maintenance

User(s): Surgeon

Maintenance: Medical staff; technician; biomedical or clinical engineer

Training: Initial training by manufacturer and manuals; supervised training with experienced surgeons

Environment of use

Settings of use: Operating room

Requirements: Stable power source

Product specifications

Approx. dimensions (mm): 245 x 220 x 154

Approx. weight (kg): 5.6

Consumables: NA

Price range (USD): 13,000 - 105,000

Typical product life time (years): 10

Shelf life (consumables): NA

Types and variations

Modular (in console); stand-alone; portable



Clinical Chemistry Analyzer

UMDNS

16298 Analyzers, Laboratory, Clinical Chemistry, Automated

GMDN

35918 Laboratory urine analyser IVD, automated
56676 Laboratory multichannel clinical chemistry analyser IVD, automated

Other common names:

Biochemistry analyzer

Health problem addressed

Perform tests on whole blood, serum, plasma, or urine samples to determine concentrations of analytes (e.g., cholesterol, electrolytes, glucose, calcium), to provide certain hematology values (e.g., hemoglobin concentrations, prothrombin times), and to assay certain therapeutic drugs (e.g., theophylline), which helps diagnose and treat numerous diseases, including diabetes, cancer, HIV, STD, hepatitis, kidney conditions, fertility, and thyroid problems.

Product description

Chemistry analyzers can be benchtop devices or placed on a cart; other systems require floor space. They are used to determine the concentration of certain metabolites, electrolytes, proteins, and/or drugs in samples of serum, plasma, urine, cerebrospinal fluid, and/or other body fluids. Samples are inserted in a slot or loaded onto a tray, and tests are programmed via a keypad or bar-code scanner. Reagents may be stored within the analyzer, and it may require a water supply to wash internal parts. Results are displayed on a screen, and typically there are ports to connect to a printer and/or computer.

Principles of operation

After the tray is loaded with samples, a pipette aspirates a precisely measured aliquot of sample and discharges it into the reaction vessel; a measured volume of diluent rinses the pipette. Reagents are dispensed into the reaction vessel. After the solution is mixed (and incubated, if necessary), it is either passed through a colorimeter, which measures its absorbance while it is still in its reaction vessel, or aspirated into a flow cell, where its absorbance is measured by a flow-through colorimeter. The analyzer then calculates the analyte's chemical concentrations.

Operating steps

The operator loads sample tubes into the analyzer; reagents may need to be loaded or may already be stored in the instrument. A bar-code scanner will read the test orders off the label on each test tube, or the operator may have to program the desired tests. After the required test(s) are run, the results can be displayed on-screen, printed out, stored in the analyzer's internal memory, and/or transferred to a computer.

Reported problems

Operators should be aware of the risk of exposure to potentially infectious bloodborne pathogens during testing procedures and should use universal precautions, including wearing gloves, face shields or masks, and gowns.



Use and maintenance

User(s): Laboratory technician

Maintenance: Laboratory technician; biomedical or clinical engineer

Training: Initial training by manufacturer and manuals

Environment of use

Settings of use: Clinical laboratory

Requirements: Adequate benchtop or floor space, water supply, line power, biohazard disposal

Product specifications

Approx. dimensions (mm): 500 x 700 x 1,000

Approx. weight (kg): 30-700

Consumables: Reagents, sample cells

Price range (USD): 10,000 - 465,000

Typical product life time (years): 5-7

Shelf life (consumables): Reagents: 1-2 years

Types and variations

Some chemistry analyzers can be interfaced to an automated immunoassay analyzer to decrease operator intervention and possibly improve workflow.



Colonoscope

UMDNS

10950 Colonoscopes

GMDN

36117 Flexible video colonoscope

Other common names:

Endoscopes; video endoscopes; Video colonoscope, flexible; Video colonoscope

Health problem addressed

Colonoscopes are used for the removal of foreign bodies, excision of tumors or colorectal polyps (polypectomy), and control of hemorrhage. Routine colonoscopy is important in diagnosing intestinal cancer, the second leading cause of cancer deaths in the United States. These endoscopic procedures reduce the need for invasive surgical diagnostic and therapeutic procedures.

Product description

These devices consist of a proximal housing, a flexible insertion tube, and an "umbilical cord" connecting the light source and the proximal housing. The proximal housing, which is designed to be held in one hand, typically includes the eyepiece (fiberoptic models only), controls for distal tip (bending section) angulation and suction, and the working channel port. Colonoscopes have several hollow channels for suction, water and air delivery, and insertion of accessory instruments and cannulae. The distal tip of video colonoscopes includes a charge-coupled device (CCD) that serves as a small camera and electronically transmits the image from the CCD to an external video-processing unit.

Principles of operation

Video colonoscope insertion tubes contains a fiberoptic light bundle, which transmits light from the light source to the tip of the endoscope. Each fiberoptic bundle consists of thousands of individual glass fibers coated with glass causing internal reflections that allow light transmission through the fiber even when it is flexed. The light is used to illuminate the field of view in the patient's colon. Video images are detected by the CCD and are then transmitted to the video processor and then display monitors or recording devices.

Operating steps

The patient typically lies on his or her side on a procedure table. Patients typically will require anesthesia or conscious sedation before insertion of the colonoscope. The colonoscope is inserted into the colon via the rectum by a gastroenterologist. Video images are typically viewed throughout the procedure on a video monitor. These images can then be recorded, printed, stored on digital media, or transmitted to another location for simultaneous viewing. The gastroenterologist manipulates the direction of the device using controls on the colonoscope control housing.

Reported problems

Although rare, trauma to the colon and adjacent organs during colonoscopy can result in complications such as bleeding, peritonitis, and appendicitis. ECRI Institute has received reports of difficulty in inserting forceps through the instrument channel of contorted colonoscopes, causing delays in procedures. Problems have occurred related to blockage of the air channel from inadequately rinsed disinfectant or retrograde flow of protein material into the channel during a procedure. Also, patient infection is a common mainly from improper cleaning and disinfection procedures.



Use and maintenance

User(s): Gastroenterologist

Maintenance: Medical staff; technician; biomedical or clinical engineer; central sterile processing technician for cleaning and disinfecting

Training: Supervised training with experienced users

Environment of use

Settings of use: Gastroenterology lab or suite, operating room

Requirements: Stable power source; access to anesthesia and patient monitoring; oxygen and suction should be available; endoscopy suite should have direct external ventilation, HEPA filtration

Product specifications

Approx. dimensions (mm): 1,700

Approx. weight (kg): 5

Consumables: NA

Price range (USD): 25,000 - 41,000

Typical product life time (years): 4 - 5

Shelf life (consumables): NA

Types and variations

Video; fiberoptic



Cryosurgical Unit

UMDNS

18051 Cryosurgical Units
11067 Cryosurgical Units, General-Purpose

GMDN

11067 Cryosurgical system, mechanical

Other common names:

Cryoextractors; Cryoprobes; Cryostats; Cryo Units; CSU; Probes, Cryosurgical

Health problem addressed

These devices provide an accepted treatment modality within the fields of dermatology, oral surgery, gynecology, urology, otolaryngology, proctology, and ophthalmology. They can be used to treat malignant and benign tumors, acne, warts, and hemorrhoids.

Product description

These devices are available as consoles or as stand-alone or handheld units. Consoles are freestanding units that typically contain cryogen gas cylinders, pressure regulators, indicators, and operating controls. They are usually battery powered and can be equipped with a probe-tip fiberoptic light source for transillumination of tissue. Stand-alone units consist of a tank, a pressure regulator, and a probe attached by tubing to the tank. Handheld units are lightweight, portable CSUs that typically use liquid nitrogen as the cryogen and are either reusable or disposable (with individual gas cartridges).

Principles of operation

CSUs apply a refrigerant (cryogen) to withdraw heat from target tissue either through direct application or indirectly through contact with a cryogen-cooled probe. There are two basic types of CSUs: those that use liquid nitrogen and those that use nitrous oxide (N₂O), carbon dioxide (CO₂), or other compressed gases. All CSUs employ either a closed or an open system. In a closed-system CSU, the cryogen flows through an insulated shaft in the hollow probe, cools the tip, and is exhausted back through the probe. Open-system CSUs apply cryogen directly to the target tissue. CSUs using N₂O or CO₂ are not usually suitable for use as open systems because cryogen "snow" would build up on the target tissue and insulate the lesion from the cryogen spray. Liquid nitrogen CSUs can be either open or closed.

Operating steps

A surgeon will use a cryosurgical unit to introduce a refrigerant to target tissue (e.g., wart, tumor) either through direct application (dabbing or spraying on) or through a cryogen-cooled probe (e.g., gun-type or pencil-shaped with either a curved or straight tip). Cryosurgically treated tissue is usually left in situ and allowed to become necrotic and slough off.

Reported problems

Few device-related problems have occurred with the use of CSUs. Of continued concern is the mechanical integrity of the units, especially the probe tips, because they are exposed to temperature and pressure extremes. Also potential damage to tissue outside of the treatment zone is a concern.



Use and maintenance

User(s): Surgeon

Maintenance: Medical staff; technician; biomedical or clinical engineer

Training: Initial training by manufacturer and manuals; supervised training with experienced surgeons

Environment of use

Settings of use: Operating room

Requirements: Stable power source

Product specifications

Approx. dimensions (mm): 690x360x660

Approx. weight (kg): 72

Consumables: Liquid nitrogen or other compressed gases

Price range (USD): 535-95000

Typical product life time (years): 10

Shelf life (consumables): Variable

Types and variations

Console; stand-alone; handheld unit



Cytometer

UMDNS

16867 Cytometers, Automated, FlowCytometers,
16503 Automated, Flow, Sorting

GMDN

57839 Flow cytometry analyser IVD, automated

Other common names:

Flow cytometer, reticulocyte analyzer, cell sorter

Health problem addressed

Used to diagnose and/or prognose leukemia, lymphoma, immunodeficiency disorders such as HIV infection, autoimmune disease, and fetal abnormalities, and to evaluate the success of transplantation procedures. Also used in cancer diagnosis and research to evaluate drug resistance, detect tumor cell DNA aneuploidy, immunophenotyping, and analyzing tumor cell proliferation. Can be adapted to provide a rapid, sensitive, and cost-effective way to detect, characterize, and identify bacteria.

Product description

Automated cytometers in which cells are dispersed in fluid suspension and flow one at a time through a narrow beam of light, typically from a laser. Each cell generates optical signals that are measured and analyzed. These cytometers include a cell transportation system, a laser for cell illumination, photodetectors for signal detection, and a computer-based management system.

Principles of operation

Specific dyes and fluorochromes are used to mark structures in or on the cells. These dyes bind to specific cellular components, such as DNA, cellular enzymes, membrane surface markers, or other antigens. Cells are suspended in a liquid stream and transported in a single-cell path to the analysis chamber. They are illuminated by a beam of high-intensity light. When exposed to light of a particular wavelength, the fluorochromes will fluoresce, emitting light of a longer wavelength than the incident light they absorb. A detection system analyzes each cell at a rate of up to 10,000 cells/second.

Operating steps

Sample cells must be treated with reagents and are loaded into the instrument. The operator may have to program the desired wavelength and parameters measured using a computer connected to the instrument.

Reported problems

Operators should be aware of the risk of exposure to potentially infectious bloodborne pathogens during testing procedures and should use universal precautions, including wearing gloves, face shields or masks, and gowns.

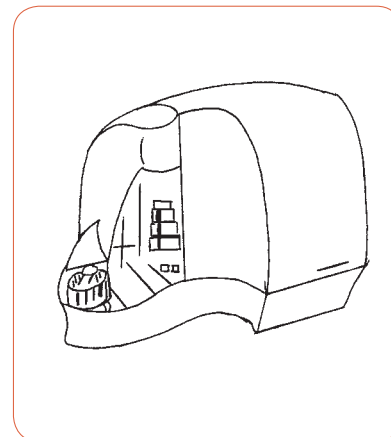

Use and maintenance

User(s): Laboratory technician

Maintenance: Laboratory technician;
biomedical or clinical engineer

Training: Initial training by manufacturer and manuals

Environment of use

Settings of use: Clinical laboratory

Requirements: Adequate benchtop or floor space, line power

Product specifications

Approx. dimensions (mm): 600 x 450 x 500

Approx. weight (kg): 50-100

Consumables: Reagents, sample cells

Price range (USD): 27,000 - 250,500

Typical product life time (years): 5-7

Shelf life (consumables): Fluorescent dyes: 1 year

Types and variations

Cell-sorting capabilities can separate and analyze specific cell types within the sample; model may have multiple lasers or an autoloader.



Defibrillator, External, Automated; Semiautomated

UMDNS

17116 Defibrillators, External, Automated
18500 Defibrillators, External, Semiautomated

GMDN

48049 Non-rechargeable professional semi-automated external defibrillator
48048 Rechargeable professional automated external defibrillator

Other common names:

AEDs, automated external defibrillators, automatic external defibrillators, semiautomated defibrillators, and shock-advisory defibrillators, PADs, automated public-access defibrillators

Health problem addressed _____

Fully automated external defibrillators (AEDs) deliver a high-amplitude current impulse to the heart in order to restore normal rhythm and contractile function in patients who are experiencing ventricular fibrillation (VF) or ventricular tachycardia (VT) that is not accompanied by a palpable pulse.

Product description _____

AEDs determine whether defibrillation is needed and automatically charge and discharge to deliver a shock. Semiautomated units analyze the ECG and charge in preparation for shock delivery, but the operator activates the discharge. AEDs typically include a memory module or PC data card, disposable adhesive defibrillation electrodes, a display to give status messages (patient and/or defibrillator), to display the ECG waveform, or to prompt the user to initiate a shock.

Principles of operation _____

Automated defibrillators analyze the ECG rhythm to determine if a defibrillation shock is needed; if it is, the defibrillator warns the operator and automatically charges and discharges. Most of these defibrillators use a single pair of disposable electrodes to monitor the ECG and deliver the defibrillator discharge, but some also incorporate ECG displays. The simple design and ease of use of automated defibrillators requires very little training and operational skill.

Operating steps _____

The operator attaches two adhesive defibrillator electrodes to the cables or directly to the AED and applies the electrodes to the patient. The AED will automatically analyze the rhythm to determine whether defibrillation is necessary. In fully automatic models, a shock is then automatically delivered when the rhythm analysis determines it is necessary. In semiautomatic units the user is prompted to deliver the shock.

Reported problems _____

Failure can be caused by defibrillator malfunction, poor electrode application, inappropriate energy selection, a cardiac physiologic state not conducive to defibrillation, or rechargeable battery issues. First- and second-degree burns are especially likely to occur during repeated defibrillation attempts (which require successively higher energies) at the paddle or electrode sites because a high current flow through a small area and/or increased resistance (due to dried gel).

Types and variations _____

Portable, carrying case



Use and maintenance _____

User(s): Emergency medical services (EMS), police officers, firefighters, traditional targeted responders (e.g., security guards, flight attendants), nontraditional responders (e.g., office staff, family members), any hospital staff trained in advance life support (ALS) or basic life support (BLS).

Maintenance: Biomedical or clinical engineer/technician, medical staff, out of hospital (e.g., airlines, shopping centers, emergency medical servicers), manufacturer/servicer

Training: Initial training by manufacturer, operator's manuals, user's guide

Environment of use _____

Settings of use: Hospital, emergency transport, emergency medical services, patient homes, public building or other public settings

Requirements: Fully charged battery/good battery care and maintenance procedures in place, uninterruptible power source (to power and recharge batteries), proper sized shock pads or electrodes, maintenance procedures to monitor shelf life of shock pads or electrodes, as well as errors returned by internal testing trials.

Product specifications _____

Approx. dimensions (mm): 100 x 250 x 200

Approx. weight (kg): 2.5

Consumables: Batteries, cables, electrodes/pads (with gel)

Price range (USD): 1,300 - 2,300

Typical product life time (years): 10

Shelf life (consumables): 1-2 years for disposable electrodes/pads



Defibrillator, External, Manual

UMDNS

11134 Defibrillators, External, Manual

GMDN

37806 Manual external defibrillator

Other common names:

Battery-powered defibrillators, cardioverters, defibrillator/monitor/ pacemakers, external biphasic defibrillators, external monophasic defibrillators, and monitor/defibrillators; DC-defibrillator, high-energy (including paddles)

Health problem addressed

Defibrillators are lifesaving devices that apply an electric shock to establish a more normal cardiac rhythm in patients who are experiencing ventricular fibrillation (VF) or another shockable rhythm.

Product description

The defibrillator charges with a large capacitor. For external defibrillation, paddles are needed to discharge on the patient's chest. Disposable defibrillation electrodes may be used as an alternative. For internal defibrillation small concave paddles are used. An ECG monitor included is used to verify a shockable rhythm and the effectiveness of treatment. Many defibrillators can be equipped with optional monitoring capabilities, such as pulse oximetry, end-tidal carbon dioxide and NIBP.

Principles of operation

Defibrillators typically have three basic modes of operation: external defibrillation, internal defibrillation, and synchronized cardioversion. (Sync mode uses a defibrillator discharge to correct certain arrhythmias, such as VT; a shock is delivered only when the control circuits sense the next R wave. The delivery of energy is synchronized with and shortly follows the peak of the R wave, preventing discharge during the vulnerable period of ventricular repolarization.) An audible/visible indicator inform when the capacitor is charged and the device is ready. ECG monitoring can be performed before, during, and after a discharge, usually through ECG electrodes, although most external paddles and disposable electrodes have ECG monitoring capability. Many defibrillators are equipped with optional monitoring capabilities (SpO₂, ETCO₂, temperature, NIBP).

Operating steps

Apply the paddles to the patient's chest and discharges the defibrillator. Synchronized cardioversion (sync mode) uses a defibrillator discharge to correct certain arrhythmias, such as VT. After verifying that the sync marker pulse appears reliably on the R wave, the operator presses and holds the paddle discharge buttons; a shock is delivered only when the control circuits sense the next R wave. The delivery of energy is synchronized with and shortly follows the peak of the R wave, preventing discharge during the vulnerable period of ventricular repolarization, which is represented by the T wave.

Reported problems

Failure can be caused by defibrillator malfunction, poor electrode application, inappropriate energy selection, a cardiac physiologic state not conducive to defibrillation, or rechargeable battery issues. First- and second-degree burns are especially likely to occur during repeated defibrillation attempts (which require successively higher energies) at the paddle or electrode sites because a high current flow through a small area and/or increased resistance (due to dried gel).



Use and maintenance

User(s): Physicians, nurses, other medical staff

Maintenance: Biomedical or clinical engineer/ technician, medical staff, manufacturer/ servicer

Training: Initial training by manufacturer, operator's manuals, user's guide

Environment of use

Settings of use: Hospital, emergency transport

Requirements: Fully charged battery/good battery care and maintenance procedures in place, uninterruptible power source (to power and recharge batteries), proper sized shock pads or electrodes, maintenance procedures to monitor shelf life of shock pads or electrodes, as well as errors returned by internal testing trials.

Product specifications

Approx. dimensions (mm): 250 x 300 x 250

Approx. weight (kg): 5.5

Consumables: Batteries, cables, paddles/ electrodes, gel

Price range (USD): 1,000 - 25,000

Typical product life time (years): 6-7

Shelf life (consumables): 1-2 years for disposable electrodes/pads

Types and variations

Cart mounted, carry case



Densitometer, Bone

UMDNS

17152 Densitometers, Bone
18382 Densitometers, Bone, Ultrasonic
17747 Densitometers, Bone, X-Ray, Dual-Energy Absorptiometry

GMDN

38314 Bone absorptiometric radionuclide system
37661 Bone absorptiometric x-ray system, dual-energy

Other common names:

Absorptiometers, X-Ray, Dual-Energy; Central DXA Systems; DEXA Systems; Diagnostic Bone Absorptiometer; Dual-Energy Densitometers; Dual-Energy X-Ray Absorptiometers; DXA Systems; Peripheral DXA Systems (pDXA); Radionuclide Systems; Ultrasonometers; Absorptiometer, dual-photon; RI bone mineral analyser; Dual-energy x-ray absorptiometry (DEXA) system

Health problem addressed _____

The primary purpose of these noninvasive measurements is to detect quantitative decreases in bone mass related to metabolic bone diseases such as osteoporosis and to assess efficacy of treatment.

Product description _____

Central DXA devices (dual-energy x-ray absorptiometers) use a dual-energy x-ray source to assess bone mineral content in the axial skeleton. These devices have a large, flat table and an "arm" suspended overhead. Ultrasonic bone densitometers measure broadband ultrasonic attenuation (BUA) and speed of sound (SOS), to provide a quantitative ultrasound index of the appendicular skeleton. Peripheral devices measure bone density in the wrist, heel or finger. The pDXA device is much smaller than the Central DXA device. It is a portable box-like structure with a space for the foot or forearm to be placed for imaging.

Principles of operation _____

DXA systems use one of two methods to create a dual-energy spectrum from an x-ray source. One method involves alternating pulses of low- and high-voltage power applied to the x-ray tube. The attenuation values of the resulting low- and high-energy x-rays are then measured separately. The other method applies a constant potential to the x-ray source while using a K-edge filter to separate the energy spectrum into two narrow energy bands. An energy-discriminating detector with a dual-channel analyzer counts the resultant photons. Ultrasonic bone densitometry systems do not rely on a radiation source but instead use sound waves to measure the integrity of the appendicular skeleton, typically through the calcaneus or phalanges of the fingers.

Operating steps _____

This examination is usually done on an outpatient basis. In the Central DXA examination, the patient lies on a padded table. An x-ray generator is located below the patient and an imaging device, or detector, is positioned above. To assess the spine, the patient's legs are supported on a padded box to flatten the pelvis and lower (lumbar) spine. To assess the hip, the patient's foot is placed in a brace that rotates the hip inward. In both cases, the detector is slowly passed over the area, generating images on a computer monitor.

Reported problems _____

No serious reports concerning the functioning of DXA scanners.



Use and maintenance _____

User(s): Bone densitometry technician

Maintenance: Medical staff; technician; biomedical or clinical engineer

Training: Initial training by manufacturer and manuals

Environment of use _____

Settings of use: Hospitals, medical offices (central DXA); mobile health vans, drugstores (pDXA)

Requirements: Stable power source; shielding for treatment room and control room (central bone densitometers)

Product specifications _____

Approx. dimensions (mm): 840 x 737 x 483

Approx. weight (kg): 181

Consumables: NA

Price range (USD): 9,180 - 199,000

Typical product life time (years): 12 to 15

Shelf life (consumables): NA

Types and variations _____

Central bone densitometers; peripheral bone densitometers



Electrocardiograph, ECG

UMDNS

16231	Electrocardiographs, Multichannel, Interpretive
18330	Electrocardiographs, Multichannel, Interpretive, Signal-Averaging
18329	Electrocardiographs, Multichannel, Noninterpretive
17687	Electrocardiographs, Multichannel, Noninterpretive, Signal-Averaging
11413	Electrocardiographs, Single-Channel

GMDN

16231	Interpretive multichannel electrocardiograph
17687	Signal-averaging multichannel electrocardiograph
11413	Single-channel electrocardiograph

Other common names:

Computer-assisted electrocardiographs; interpretive ECG machines; interpretive electrocardiographs; automated electrocardiographs; EKG machines; Electrocardiograph multichannel;

Health problem addressed

Electrocardiographs detect the electrical signals associated with cardiac activity and produce an ECG, a graphic record of the voltage versus time. They are used to diagnose and assist in treating some types of heart disease and arrhythmias, determine a patient's response to drug therapy, and reveal trends or changes in heart function. Multichannel electrocardiographs record signals from two or more leads simultaneously and are frequently used in place of single-channel units. Some electrocardiographs can perform automatic measurement and interpretation of the ECG as a selectable or optional feature.

Product description

ECG units consist of the ECG unit, electrodes, and cables. The 12-lead system includes three different types of leads: bipolar, augmented or unipolar, and precordial. Each of the 12 standard leads presents a different perspective of the heart's electrical activity; producing ECG waveforms in which the P waves, QRS complex, and T waves vary in amplitude and polarity. Single-channel ECGs record the electric signals from only one lead configuration at a time, although they may receive electric signals from as many as 12 leads. Noninterpretive multichannel electrocardiographs only record the electric signals from the electrodes (leads) and do not use any internal procedure for their interpretation. Interpretive multichannel electrocardiographs acquire and analyze the electrical signals.

Principles of operation

Electrocardiographs record small voltages of about one millivolt (mV) that appear on the skin as a result of cardiac activity. The voltage differences between electrodes are measured; these differences directly correspond to the heart's electrical activity. Each of the 12 standard leads presents a different perspective of the heart's electrical activity; producing ECG waveforms in which the P waves, QRS complex, and T waves vary in amplitude and polarity. Other lead configurations include those of the Frank system and Cabrera leads. The Frank configuration measures voltages from electrodes applied to seven locations—the forehead or neck, the center spine, the midsternum, the left and right midaxillary lines, a position halfway between the midsternum and left midaxillary electrodes, and the left leg.

Operating steps

After the electrodes are attached to the patient, the user selects automatic or manual lead switching, signal sensitivity, frequency-response range, and chart speed. In some units, the operator can choose the lead groupings, their sequence, and the recording duration for each group. In standard 12-lead tracings, signals from each group of leads (i.e., bipolar, augmented, precordial) can be recorded for 2.5 seconds. For a rhythm strip, one lead (usually lead II) is recorded for a full 12 seconds.

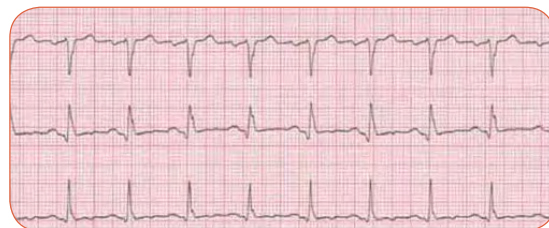

Reported problems

Because electrocardiographs have electrical safety standards that are well established and adhered to by all major manufacturers, few problems are associated with their use. Of these, the most common is artifact or noise (e.g., broken electrode wires, poor electrode cleaning or improper application, poor skin preparation, patient movement, baseline drift, and interference). Incorrect placement of ECG leads can cause an abnormality to be overlooked. Chest wall thickness can also affect diagnostic accuracy.

Use and maintenance

User(s): Physicians, nurses, other medical staff

Maintenance: Biomedical or clinical engineer/technician, medical staff, manufacturer/servicer

Training: Initial training by manufacturer, operator's manuals, user's guide

Environment of use

Settings of use: Hospital (all areas), family medicine practices and other medical offices

Requirements: Uninterruptible power source, battery backup, appropriate electrodes

Product specifications

Approx. dimensions (mm): 120 x 400 x 350

Approx. weight (kg): 6

Consumables: Batteries, cables, electrodes

Price range (USD): 975 - 6,000

Typical product life time (years): 10

Shelf life (consumables): 1-2 years for disposable electrodes/sensors

Types and variations

Portable, cart, desktop, tabletop



Electrosurgical Unit

UMDNS

11490	Electrosurgical Units
18230	Electrosurgical Units, Bipolar
18229	Electrosurgical Units, Monopolar
18231	Electrosurgical Units, Monopolar/Bipolar

GMDN

44776	General-purpose electrosurgical diathermy system
-------	--

Other common names:

Bovies; Coagulators, Electrosurgical; Diathermy Units, Surgical; Electrocautery Units; Electrosurgical Generators; Endometrial Ablation Systems; ESUs; Hyfrecators; Malis Coagulators; Stimulators, Muscle; Surgical Diathermy Units; Surgical Units; Wapplers; Apparatus, electrosurgical; Surgical diathermy generator

Health problem addressed

Devices intended for surgical cutting and for controlling bleeding by causing coagulation (hemostasis) at the surgical site. Electrosurgery is commonly used in dermatological, gynecological, cardiac, plastic, ocular, spine, ENT, maxillofacial, orthopedic, urological, neuro- and general surgical procedures as well as certain dental procedures.

Product description

These systems include an electrosurgical generator (i.e., power supply, waveform generator) and a handpiece including one or several electrodes.

Principles of operation

In monopolar electrosurgery, tissue is cut and coagulated by completion of an electrical circuit that includes a high-frequency oscillator and amplifiers within the ESU, the patient, the connecting cables, and the electrodes. In most applications, electric current from the ESU is conducted through the surgical site with an active cable and electrode. The electrosurgical current exits the patient through a dispersive electrode (usually placed on the patient at a site remote from the surgical site) and its associated cable connected to the neutral side of the generator. In bipolar electrosurgery, two electrodes (generally, the two tips of a pair of forceps or scissors) serve as the equivalent of the active and return electrodes in the monopolar mode.

Operating steps

Electrosurgical procedures may or may not be performed with the patient under anesthesia. The patient is prepped and electrodes are applied to the affected areas. Electrical current is delivered to the affected area and the surrounding tissue is heated to cause desiccation, vaporization, or charring to remove diseased or damaged tissue.

Reported problems

There is a risk of surgical fire when using oxygen while performing electrosurgery. Partial or complete detachment of the electrode pad from the patient is a common cause of patient burns. Burns may also result from inadequate site preparation, defective materials or construction, or incorrect placement of the return electrode. The second most common type of electrosurgical injury occurs when the active electrode is inadvertently energized while the tip is in contact with nontarget tissue.



Use and maintenance

User(s): Surgeon

Maintenance: Medical staff; technician; biomedical or clinical engineer

Training: Initial training by manufacturer and manuals; supervised training with experienced surgeons

Environment of use

Settings of use: Hospital operating room

Requirements: Stable power source; smoke evacuation

Product specifications

Approx. dimensions (mm): 777 x 360 x 505

Approx. weight (kg): 28

Consumables: Active and return electrodes

Price range (USD): 1,500 - 14,000

Typical product life time (years): 7 to 10

Shelf life (consumables): Single use or variable

Types and variations

Bipolar unit; monopolar unit; monopolar/bipolar unit



Fetal Heart Detector, Ultrasonic

UMDNS

11696 Detectors, Fetal Heart, Ultrasonic

GMDN

35068 Foetal heart detector, ultrasonic

Other common names:

Ultrasonic stethoscopes; fetal Dopplers; Monitor, heart rate, fetal ultrasonic; Monitor, heart sound, fetal, ultrasonic; monitor, hemic sound, ultrasonic.

Health problem addressed

Ultrasonic fetal heart detectors are low-cost devices used in a variety of healthcare settings to provide audible and visual information about the fetus. The unit provides quick reassurance of fetal well-being to both the mother and the healthcare worker. Fetal heart detectors can easily detect fetal heart sounds throughout the pregnancy, starting as early as 8 weeks. The ability of most units to accurately calculate the fetal heart rate has also made these devices valuable diagnostic tools.

Product description

Fetal heart detectors are devices that use ultrasonic waves to provide audible and/or visual information. They consist of an ultrasound-frequency electrical generator and appropriate ultrasound transducers housed in a probe that is placed on the maternal abdomen. Ultrasonic heartbeat detectors amplify the audible frequency shift signal of the returned ultrasonic waves and deliver it to speakers or headphones; the heart rate is determined either by measuring the timing of the peaks in the Doppler signal or, more accurately, by using automated autocorrelation procedures. These devices can detect fetal heart activity as soon as 10 weeks after conception. Advanced units can even detect bidirectional blood flow, allowing the clinician to evaluate maternal vessels, such as the uterine artery.

Principles of operation

Fetal heart detectors transmit high-frequency sound waves either continuously or in pulses. In continuous-wave (CW) units, a crystal vibrates as an electrical current passes through it, creating and transmitting acoustic energy, while a second crystal detects echoes from structures in the body. In pulsed-Doppler systems, a single crystal alternately transmits periodic bursts of ultrasonic waves and senses the echoed energy. In both systems, the reflected wave is reconverted to an electrical signal that can be used to create an audible sound or a waveform. Ultrasonic heartbeat detectors amplify the audible frequency shift signal of the returned ultrasonic waves and deliver it to speakers or headphones; the heart rate is determined either by measuring the timing of the peaks in the Doppler signal or by using automated autocorrelation procedures.

Operating steps

An acoustic coupling gel is spread over the skin to facilitate the efficient transmission of ultrasound waves into and out of the body. The probe is placed against the mother's abdomen. If the scanned structures are in motion, the frequency of the returning sound waves changes in proportion to the velocity and direction of the moving structures. Fetal heart detectors amplify this audible frequency change, known as Doppler shift, and channel it to speakers or headphones.

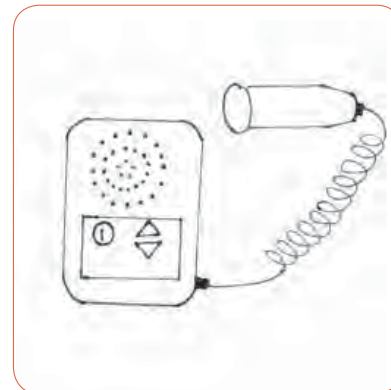

Reported problems

Although researchers have yet to establish whether a significant risk exists, there is some concern about whether exposure to ultrasonic energy during diagnostic procedures is safe. Many factors can affect the ability of the unit to detect the fetal heartbeat (i.e., body fat and blood flow can absorb acoustic energy). Since pathogens may be present on the patient's skin, transmission of these organisms to the transducer head commonly occurs.

Use and maintenance

User(s): Physicians, obstetric nurses, community midwives

Maintenance: Biomedical or clinical engineer/technician, medical staff, manufacturer/servicer

Training: Initial training by manufacturer, operator's manuals, user's guide

Environment of use

Settings of use: Obstetrics (hospital, OB/GYN practices), emergency medicine

Requirements: Battery, uninterruptible power source (recharge batteries), appropriate transducer with gel

Product specifications

Approx. dimensions (mm): 100 x 150 x 200

Approx. weight (kg): 1

Consumables: Batteries, gel

Price range (USD): 350 - 800

Typical product life time (years): 8

Shelf life (consumables): NA

Types and variations

Portable, handheld, tabletop units



Fetal monitor

UMDNS

18339 Monitors, Bedside, Fetal, Antepartum
18340 Monitors, Bedside, Fetal, Intrapartum

GMDN

43958 Foetal cardiac monitor

Other common names:

Cardiotocographs; fetal electrocardiogram (ECG) monitors; fetal heart rate monitors; ultrasonic fetal monitors; Monitor, cardiac, fetal; Monitor, heart valve movement, fetal, ultrasonic; Monitor, phonocardiographic, fetal.

Health problem addressed

Electronic fetal monitoring (EFM) provides graphic and numeric information on fetal heart rate (FHR) and maternal uterine activity (UA) to help clinicians assess fetal well-being before and during labor. FHR often exhibits decelerations and accelerations in response to uterine contractions or fetal movements; certain patterns are indicative of hypoxia. Examination of these patterns, the baseline level, and variability characteristics can indicate the need to alter the course of labor with drugs or perform an operative delivery.

Product description

Fetal monitors are bedside units that consist of a monitoring unit, cables, and electrodes. They are designed to measure, record, and display FHR, uterine contractions, and/or maternal blood pressure and heart rate before and during childbirth. These monitors may sense FHR and uterine contraction indirectly through the mother's abdomen and/or directly by placing an electrode on the fetal scalp (or other exposed skin surface) and measuring the change in pressure within the uterus. Antepartum fetal monitors are typically used in physician's offices and clinics long before the beginning of labor. Most hospital-based monitors have additional capabilities, including fetal and maternal ECG recording.

Principles of operation

Fetal monitors detect FHR externally by using an ultrasound transducer to transmit and receive ultrasonic waves; the frequency (or Doppler) shift of the reflected signal is proportional to the velocity of the reflecting structure—in this case, the fetal heart. A transducer contains one or more piezoelectric elements that convert an electrical signal into ultrasonic energy that can be transmitted into tissues. When this ultrasonic energy is reflected back from the tissues, the transducer reconverts it to an electrical signal that can be used to create a waveform for display and recording and an audible FHR (sound created by the frequency shift of the ultrasonic signal).

Operating steps

Continuous electronic FHR monitoring can be performed indirectly, by applying an ultrasound transducer to the mother's abdomen, or directly, by attaching an electrode assembly to the fetus after rupture of the amniotic membranes. Uterine contractions can be recorded along with FHR by placing a pressure transducer on the mother's abdomen or by directly measuring the change in pressure in the uterus with a catheter.

Reported problems

Common errors include doubled or halved rates, masked fetal arrhythmias, and presentation of the maternal heart rate as the FHR. Another error is the report of false FHR decelerations during uterine contractions due to ultrasonic signal-processing circuits holding the last FHR on occasional signal peaks during noisy signals. Reported complications

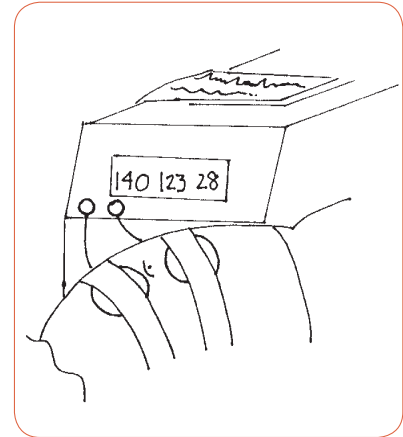

of fetal scalp electrode application include infection, uterine perforation, and soft tissue injuries; mostly resulting from poor technique. Some investigators have expressed concern about the possible risks associated with fetal exposure to ultrasound.

Use and maintenance

User(s): Physicians, obstetric nurses, community midwives

Maintenance: Biomedical or clinical engineer/technician, medical staff, manufacturer/servicer

Training: Initial training by manufacturer, operator's manuals, user's guide

Environment of use

Settings of use: Obstetrics (hospital, OB/GYN practices), emergency medicine

Requirements: Uninterruptible power source, battery backup, appropriate transducer/electrodes/sensors

Product specifications

Approx. dimensions (mm): 100 x 150 x 200

Approx. weight (kg): 6

Consumables: Batteries, cables, electrodes/sensors, gel

Price range (USD): 1,200 - 15,000

Typical product life time (years): 8

Shelf life (consumables): NA

Types and variations

Tabletop, cart, some portable



Glucose Analyzer

UMDNS

16488 Analyzers, Point-of-Care, Whole Blood Glucose
15102 Analyzers, Laboratory, Body Fluid, Glucose

GMDN

56684 Home-use/point-of-care glucose analyser IVD
56685 Battery-powered Home-use/point-of-care glucose analyser IVD
44206 Line-powered Laboratory glucose analyser IVD, automated

Other common names:

Glucometers, glucose meters, glucose monitors, blood sugar meters

Health problem addressed _____

Used to test for and manage diabetes by measuring blood glucose levels; also used to test for transient high or low glucose levels (e.g., during surgery); they are also used in sports medicine.

Product description _____

Handheld device with a display (usually LCD), a keypad to enter information, and a slot to insert a test strip containing a drop of blood which is tested for glucose. Some models may have alarms, memory functions, touchpens, USB ports or wireless features to transfer data to a computer, and/or a small storage compartment for test strips.

Principles of operation _____

In optical BGMs, the blood sample is exposed to a membrane covering the reagent pad, which is coated with an enzyme (glucose oxidase, glucose dehydrogenase). The reaction causes a color change; the intensity of this change is directly proportional to the amount of glucose in the blood sample. Light from an LED strikes the pad surface and is reflected to a photodiode, which measures the light's intensity and converts it to electrical signals. Electrochemical BGMs use an electrode sensor to measure the current produced when the enzyme converts glucose to gluconic acid. The resulting current is directly proportional to the amount of glucose in the sample.

Operating steps _____

The test strip is inserted into the device either before or after the addition of blood to the pad; timing begins automatically when the monitor senses blood on the strip. Within seconds, a reading is taken and displayed.

Reported problems _____

Outdated or improperly stored test strips can produce inaccurate glucose readings. Healthcare personnel who use BGMs in multiple-patient facilities should be aware of the risk of exposure to potentially infectious bloodborne pathogens during testing and cleaning procedures. Cross-contamination can occur if appropriate infection control measures are not taken. Lancing devices can cause needlestick injuries.



Use and maintenance _____

User(s): Patient, clinician, nurse

Maintenance: Patient or clinician

Training: Training manual

Environment of use _____

Settings of use: Home, hospital, physician clinic

Requirements: NA (battery-operated handheld devices do not have special settings requirements)

Product specifications _____

Approx. dimensions (mm): 90 x 50 x 100

Approx. weight (kg): 0.65

Consumables: Test strips, batteries

Price range (USD): 15 - 1500

Typical product life time (years): 5-7

Shelf life (consumables): Test strips: 6 months

Types and variations _____

Specialized devices for neonate may be available; some devices not intended for use with neonates; some models allow alternate-site testing (fingertip, forearm, palm)



Hematology Point of Care Analyzer

UMDNS

18513 Analyzers, Point-of-Care, Whole Blood, Hematology

GMDN

35476 Haematological cell analyser IVD, automated

Other common names:

POC Analyzer, hematology analyzer; Analyser, laboratory, haematology, cell counting, automated

Health problem addressed

Used to count blood cells. An abnormal red cell count may indicate polycythemia or anemia, which occurs because of blood loss, failure of the bone marrow to produce RBCs, vascular hemolysis, hypersplenism, or deficiencies of iron, vitamin B12, or folic acid. Abnormal white cell counts may indicate allergies, bacterial or viral infections, inflammatory disorders, tumors, tissue destruction, toxic metabolic states, leukemia, myeloproliferative syndromes, parasitic infections, or typhoid fever.

Product description

Handheld device or benchtop device, sometimes placed on a cart, with a display (usually LCD), a keypad to enter information, and a slot to insert a test strip or sample tube. Some models may have alarms, memory functions, touchpens, USB ports to transfer data to a computer, and/or a small storage compartment for reagents.

Principles of operation

Red blood cell, white blood cell, and platelet counts are obtained using the volumetric impedance technique, which creates pulses which are amplified; the magnitude of the pulse is directly proportional to the volume of the cell. Another method is the light-scatter technique, which counts and sizes cells by detecting the amount of light scattered by a stream of hydrodynamically focused cells. Within minutes of placing the sample into the analyzer, the sample's cells have been quantified, and results are analyzed and displayed.

Operating steps

Whole blood samples are placed in tubes, on reaction cuvettes, or on test strips, and loaded into the analyzer. The operator may select the tests being performed on the sample using a keypad or connected computer.

Reported problems

Operators should be aware of the risk of exposure to potentially infectious bloodborne pathogens during testing procedures and should use universal precautions, including wearing gloves, face shields or masks, and gowns.

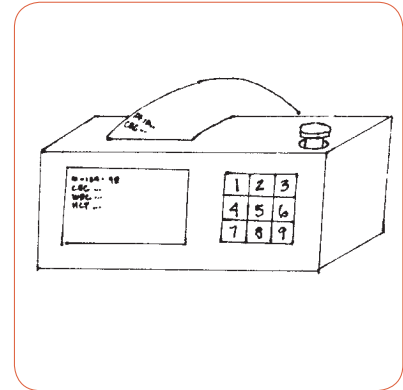

Use and maintenance

User(s): Medical staff

Maintenance: Laboratory technician; biomedical or clinical engineer

Training: Initial training by manufacturer and manuals

Environment of use

Settings of use: Hospital, patient bedside, physician office, clinical laboratory, home

Requirements: Battery-operated handheld devices do not have special settings requirements; benchtop units require line power

Product specifications

Approx. dimensions (mm): 100 x 300 x 400

Approx. weight (kg): 1-5 for handheld units; 15-25 for benchtop units

Consumables: Reagent cartridges or test strips, batteries

Price range (USD): 191 - 28,000

Typical product life time (years): 4-6

Shelf life (consumables): Reagents: 1-2 years

Types and variations

Handheld, portable, benchtop



Hemodialysis Unit

UMDNS

11218 Hemodialysis Units

GMDN

34995 Haemodialysis system

Other common names:

Artificial Kidneys; Dialysis Machines; Hemodialyzers; Hemodialysis Machines; System, dialysate delivery, sealed; System, dialysate delivery, sorbent regenerated; Haemodialysis apparatus

Health problem addressed _____

These devices perform extracorporeal dialysis to replace the main activity of the kidneys in patients with impaired renal function, such as those with end-stage renal disease.

Product description _____

Single-patient hemodialysis systems can be divided into three major components: the dialysate delivery system, the extracorporeal blood-delivery circuit, and the dialyzer.

Principles of operation _____

Single-patient hemodialysis systems can be divided into three major components: the dialysate delivery system, the extracorporeal blood-delivery circuit, and the dialyzer. Blood is taken via the extracorporeal circuit, passed through a dialyzer for solute and fluid removal, and returned to the patient. Each system has its own monitoring and control circuits. The delivery system prepares dialysate—a solution of purified water with an electrolyte composition similar to that of blood—and delivers it to the dialyzer. The external blood-delivery system (extracorporeal blood circuit) circulates a portion of the patient's blood through the dialyzer and returns it to the patient. The dialyzer is a disposable component in which solute exchange, or clearance, takes place.

Operating steps _____

Blood is taken via the extracorporeal circuit, passed through a dialyzer for solute and fluid removal, and returned to the patient.

Reported problems _____

Infections are a leading cause of morbidity and mortality in chronic hemodialysis patients. For example, HBsAg (an indicator for the presence of hepatitis B virus) has been detected on various surfaces in hemodialysis centers. Strict, specific policies and procedures designed to reduce infection risks should be implemented. These policies should address issues such as sterilization and disinfection, housekeeping, laundry, maintenance, waste disposal, isolation precautions, and universal precautions.

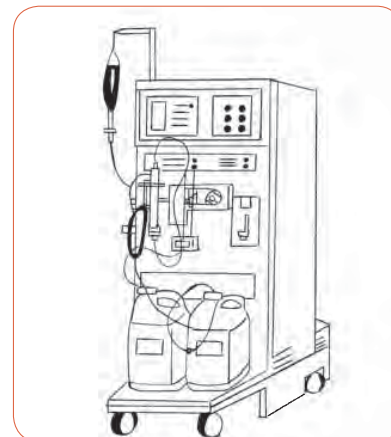

Use and maintenance _____

User(s): Nurse; dialysis technician

Maintenance: Medical staff; technician; biomedical or clinical engineer

Training: Initial training by manufacturer and manuals

Environment of use _____

Settings of use: Dialysis department at hospitals; dialysis clinics

Requirements: Stable power source; water treatment capability (e.g., reverse osmosis, deionization)

Product specifications _____

Approx. dimensions (mm): 1680 x 510 x 640

Approx. weight (kg): 85

Consumables: Dialysate and administration sets

Price range (USD): 37,000

Typical product life time (years): 5 to 7

Shelf life (consumables): variable and single use

Types and variations _____

Single patient; multiple patient



Immunoassay Analyzer

UMDNS

18625 Analyzers, Laboratory, Immunoassay

GMDN

56724 Multichannel immunoassay analyser IVD, automated

Other common names:

IA analyzer, EIA analyzer, FIA analyzer, CIA analyzer, enzyme photometric analyzer, immunofluorescence analyzer, luminescent analyzer

Health problem addressed _____

Immunoassay analyzers test patient samples for a variety of substances, including antiarrhythmic, antibiotic, anticonvulsant, or cardiac glycoside drug concentration determination; infectious diseases; allergy testing; cardiac markers; endocrine hormone testing; and protein, viral, or bacterial toxin determinations.

Product description _____

Laboratory analyzers used to identify and quantify specific substances, typically using an antibody (e.g., immunoglobulin) as a reagent to detect the substance (i.e., antigen, hapten) of interest. These analyzers typically include an autosampler, a reagent dispenser, a washer, and a detection system. Configuration and levels of sophistication, as well as available testing options, vary greatly.

Principles of operation _____

Labeled molecules are added to patient specimens and passed through a light of a particular wavelength. If the labeled molecules bind to the molecules in the patient specimen, the bound molecules will emit light. This indicates a positive result that can then be quantified. The light signals are captured by a detector and analyzed by the system's computer. Models may use an enzyme-substrate system, a fluorescent substance (either a natural substance or a dye), or an acridinium ester or luminol.

Operating steps _____

The operator loads sample cells into the analyzer; reagents are already stored in the instrument. Typically, a bar-code scanner will read the test orders off the label on each test tube. The analyzer will perform the required test(s), and the results can be displayed on-screen, printed out, stored in the analyzer's internal memory, and/or transferred to a computer.

Reported problems _____

Operators should be aware of the risk of exposure to potentially infectious bloodborne pathogens during testing procedures and should use universal precautions, including wearing gloves, face shields or masks, and gowns.

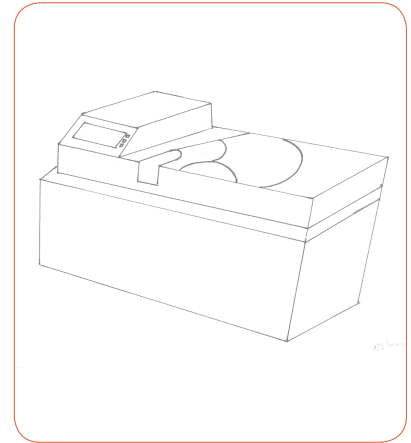

Use and maintenance _____

User(s): Laboratory technician

Maintenance: Laboratory technician; biomedical or clinical engineer

Training: Initial training by manufacturer and manuals

Environment of use _____

Settings of use: Clinical laboratory

Requirements: Adequate benchtop or floor space, water supply, line power, biohazard disposal

Product specifications _____

Approx. dimensions (mm): 600 x 750 x 1,000

Approx. weight (kg): 10-60

Consumables: Reagents (cartridges, test strips, etc.), reaction cuvettes

Price range (USD): 4,278 - 339,000

Typical product life time (years): 5-7

Shelf life (consumables): Reagents: 1-2 years

Types and variations _____

Enzyme, fluorescence, or chemiluminescence methodologies; some models can be interfaced to an automated chemistry analyzer to decrease operator intervention and possibly improve workflow.



Incubator, Infant

UMDNS

12113 Incubators, Infant
17432 Incubators, Infant, Mobile
12114 Incubators, Infant, Transport

GMDN

35121 Transport infant incubator
36025 Conventional infant incubator

Other common names:

Beds, Infant; Combination Incubator/Warmers; Infant Incubators; Infant Warmers; Neonatal Care Stations; Transport Incubators; Warmers; Thermostated transportable incubator; Incubator, neonatal transport

Health problem addressed _____

At birth, an infant's core and skin temperatures tend to drop significantly because of heat loss from conduction, convection, radiation, and water evaporation. Prolonged cold stress in neonates can cause oxygen deprivation, hypoglycemia, metabolic acidosis, and rapid depletion of glycogen stores.

Product description _____

Bassinet enclosed in plastic with climate controlled equipment and hand-access ports with doors that are intended to keep infants warm and limit their exposure to germs.

Principles of operation _____

These devices provide a closed, controlled environment that warms an infant by circulating heated air over the skin. The heat is then absorbed into the body by tissue conduction and blood convection. Ideally, both the skin and core temperatures should be maintained with only minor variations.

Operating steps _____

The neonate lies on a mattress in the infant compartment, which is enclosed by a clear plastic hood. Incubators have hand-access ports with doors that permit the infant to be handled while limiting the introduction of cool room air. The clinician can raise or remove the plastic hood or open a panel to gain greater access to the infant.

Reported problems _____

Deaths and injuries to neonates in incubators have been linked to thermostat failure that caused incubator overheating and infant hyperthermia and to malfunctions or design defects that produced fires and electric shock hazards. Inadequate control over the amount of oxygen delivered in an incubator can cause hyperoxia or hypoxia.

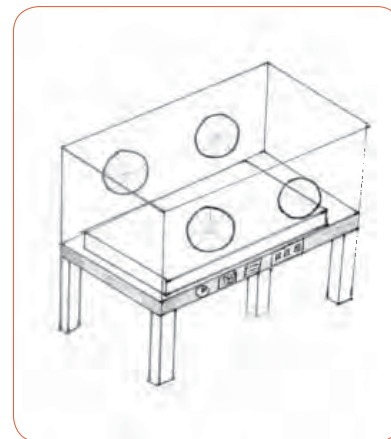

Use and maintenance _____

User(s): Nursing staff

Maintenance: Medical staff; technician; biomedical or clinical engineer

Training: Initial training by manufacturer and manuals

Environment of use _____

Settings of use: Hospital (primary care, intermediate care, intensive care areas); transport units used in ambulances

Requirements: Stable power source

Product specifications _____

Approx. dimensions (mm): 1326 x 1040 x 750

Approx. weight (kg): 93

Consumables: NA

Price range (USD): 13,000 - 43,000

Typical product life time (years): 7 to 10

Shelf life (consumables): NA

Types and variations _____

Incubator; incubator/warmer; transport; mobile



Laser, CO₂

UMDNS

18203	Lasers, Carbon Dioxide
18204	Lasers, Carbon Dioxide, Dental
16942	Lasers, Carbon Dioxide, Surgical/Dermatologic

GMDN

35939	Surgical/dermatological carbon dioxide laser system
47878	Dental carbon dioxide laser system

Other common names:

Carbon Dioxide Lasers; Laser, ENT, microsurgical carbon dioxide; Laser, surgical, carbon dioxide, general-purpose; Laser, surgical, carbon dioxide, speciality

Health problem addressed

The CO₂ laser is applied extensively in gynecology, genitourinary, plastic, dental, hepatic, orthopedic, and cardiovascular surgery and are considered the mainstay of laser neurosurgery. They are used for cutting, dissection, and coagulation of a wide range of tissues.

Product description

Devices that typically consist of a laser tube, a laser pump, a cooling system, an aiming laser, and a delivery system. A typical CO₂ laser delivery system consists of a hollow articulated arm with mirrors set in each rotating joint so that the handpiece can aim the beam in any direction. The handpiece has a focusing lens to control spot size and focal length.

Principles of operation

CO₂ lasers have two main modes of operation: continuous wave (CW) and pulsatile (e.g., superpulse, pulser). In the CW mode, the laser continuously delivers energy as long as the footpedal is depressed. This mode releases the highest average power, but it is the least precise of the operating modes. Pulsatile modes allow the laser to fire much shorter pulses than the CW mode. Superpulse emits pulses that are 200 to 1,000 microseconds (μ sec) long; it is used when precise control is necessary. Pulser, a second type of pulsatile mode, emits energy for 2 to 25 milliseconds (msec). A newer, highly developed type of pulsatile mode is ultrapulse; the peak energy of each pulse in this mode lasts longer than that of superpulse, subjecting tissue to a substantially greater amount of energy per pulse.

Operating steps

These devices are intended to create surgical incisions, to excise or vaporize deeper tissues (e.g., to remove tumors) after incisions, to coagulate very small bleeding vessels, to vaporize surface anomalies (e.g., warts), and to excise or vaporize tissue accessible by both rigid and flexible endoscopes.

Reported problems

Serious eye injuries have resulted from exposure to direct or reflected laser light; many of these injuries occurred because eye protection was inappropriate. Fire is a risk, particularly during laser surgery in the area of the head and neck. Oxygen and nitrous oxide can enter the surgical site or collect in the oropharyngeal cavity and increase the flammability of nearby materials. Other risks include excessive bleeding resulting from the CO₂ laser's inability to effectively coagulate blood vessels.

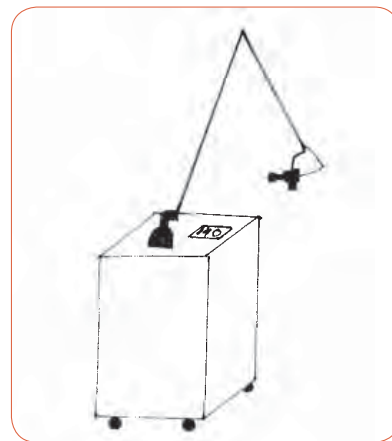

Use and maintenance

User(s): Surgeon

Maintenance: Medical staff; technician; biomedical or clinical engineer

Training: Initial training by manufacturer and manuals

Environment of use

Settings of use: Hospital; clinic; physician office

Requirements: Stable power source; smoke evacuation

Product specifications

Approx. dimensions (mm): 350 x 400 x 1190

Approx. weight (kg): 49

Consumables: CO₂ compressed gas

Price range (USD): 13,019-75,000

Typical product life time (years): 7

Shelf life (consumables): Variable

Types and variations

Free-flowing tube; sealed tube



Laser, Ophthalmic

UMDNS

16945	Lasers, Argon, Ophthalmic
17773	Lasers, Argon/Krypton, Ophthalmic
17808	Lasers, Diode, Ophthalmic
17481	Lasers, Dye, Ophthalmic
18224	Lasers, Er:YAG, Ophthalmic
17702	Lasers, Excimer, Ophthalmic
18227	Lasers, Excimer/Ho:YAG, Ophthalmic
16946	Lasers, Krypton, Ophthalmic
16947	Lasers, Nd:YAG, Ophthalmic

GMDN

16945	Ophthalmic argon laser system
36171	Ophthalmic argon/krypton laser system
44731	Ophthalmic diode-pumped solid-state laser system
17481	Ophthalmic dye laser system
17702	Ophthalmic excimer laser system
36532	Ophthalmic krypton laser system
16947	Ophthalmic Nd:YAG laser system

Other common names:

Coagulators, Laser, Ophthalmic; Coagulators, Optical; Laser Coagulators, Ophthalmic; Photocauteries; Photocoagulation Lasers; Photocoagulators; Semiconductor laser therapy equipment; Diode-pumped solid-state (DPSS) laser

Health problem addressed

Devices used to coagulate abnormal vascular tissue in the retina. Proliferation of such tissue (diabetic retinopathy) may lead to blindness. They may create highly localized perforations in the iris or in the trabecular meshwork to relieve excessive intraocular pressure (glaucoma). They can also be used to reshape the cornea to correct vision problems.

Product description

Most ophthalmic laser systems consist of a laser module—a laser medium, laser pump, laser cavity, and cooling system that is typically coupled to a slit-lamp biomicroscope by a flexible fiberoptic cable. Other laser-energy delivery systems include indirect ophthalmoscopes, intraocular probes, and interfaces for operating microscopes.

Principles of operation

These devices are grouped into three main types: photocoagulating lasers, photodisrupting lasers, and photoablating lasers. Some ophthalmic lasers are also used for photodynamic therapy. For photocoagulation ophthalmologists use argon, dye, krypton, diode, and frequency-doubled Nd:YAG lasers to coagulate abnormal vascular tissue in the retina. Dye and diode lasers are being used in the photodynamic treatment of intraocular tumors. Q-switched Nd:YAG ophthalmic lasers are used for microsurgery in the anterior portions of the eye. Excimer lasers are used in phototherapeutic keratectomy to smooth over corneal scarring and remove calcification plaques, in photorefractive keratectomy to shape the cornea to correct myopia, and in automated lamellar keratoplasty to correct both myopia and hyperopia.

Operating steps

The ophthalmologist views the structures within the patient's eye and aims and focuses the laser through the optics of the slit lamp; when the laser is fired, the energy is delivered through these optics or through coaxial optics.

Reported problems

Adverse outcomes include hemorrhage in and behind the retina, retinal membrane contraction, atrophy of the iris, corneal edema and neovascularization, loss of blue vision, changes in corneal epithelial cell density, and increased intraocular pressure. Using an Nd:YAG laser in the presence of an IOL can pit the lens, affecting visual acuity.



Use and maintenance

User(s): Surgeon

Maintenance: Medical staff; technician; biomedical or clinical engineer

Training: Initial training by manufacturer and manuals; supervised training with experienced surgeons

Environment of use

Settings of use: Hospital; clinic

Requirements: Stable power source

Product specifications

Approx. dimensions (mm): 130 x 220 x 250

Approx. weight (kg): 47

Consumables: NA

Price range (USD): 75,000

Typical product life time (years): 7

Shelf life (consumables): NA

Types and variations

With integrated slit lamp; without integrated slit lamp



Mammography unit

UMDNS

12425 Radiographic Units, Mammography;
18432 Radiographic Systems, Digital, Mammography

GMDN

37672 Stationary mammographic x-ray system, digital

Other common names:

Mammo units; X-ray system, diagnostic, mammographic, stationary, digital

Health problem addressed

Mammographic radiographic units use x-rays to produce images of the breast—a mammogram—that provide information about breast morphology, normal anatomy, and gross pathology. Mammography is used primarily to detect and diagnose breast cancer and to evaluate palpable masses and nonpalpable breast lesions.

Product description

A complete mammographic radiographic system includes an x-ray generator, an x-ray tube and gantry, and a recording medium. The x-ray generator modifies incoming voltage to provide the x-ray tube with the power necessary to produce an x-ray beam. They also include a “paddle” for compression and placement of the breasts during imaging. Screen-film systems consist of a high-resolution phosphorescent screen with phosphor crystals that emit light when exposed to x-rays. Digital mammographic computed radiography (CR) uses a “digital” cassette to replace the traditional film cassette and digital cassette reader, producing a digital image from the cassette instead of developing film through a film processor.

Principles of operation

Low energy X-rays are produced by the x-ray tube (an evacuated tube with an anode and a cathode) when a stream of electrons, accelerated to high velocities by a high-voltage supply from the generator, collides with the tube's target anode. The cathode contains a wire filament that, when heated, provides the electron source. The target anode is struck by the impinging electrons. X-rays exit the tube through a port window of beryllium. Additional filters are placed in the path of the x-ray beam to modify the x-ray spectrum. The x-rays that pass through the filter are shaped by either a collimator or cone apertures and then directed through the breast.

Operating steps

The mammography technician positions the patient, aligns the X-ray tube for projection, compresses the patient's breast with the compression paddles, and then steps away to avoid X-ray exposure before initiating the exposure to the patient. Developed images are typically sent to a view box or workstation for viewing.

Reported problems

Historically, the most common problems associated with mammography have not involved the units themselves but rather are related to radiation exposure risks to patients. Inadequate compression of the breast can cause poor image quality on mammograms. Sagging of the breast during mediolateral oblique and 90° lateral views, underexposure of the thick posterior part of the breast and overexposure of the thin anterior part, blurring of calcifications, and uneven exposure of fibroglandular tissue can result if compression is not properly applied during imaging.



Use and maintenance

User(s): Radiology/mammography technician, radiologist

Maintenance: Biomedical or clinical engineer/technician, radiology staff, manufacturer/servicer

Training: Initial training by manufacturer, operator's manuals, user's guide

Environment of use

Settings of use: Radiology departments, mammography clinics, stand-alone imaging centers, mobile (i.e., trailer- or truck-based) units

Requirements: Stable power source; appropriate shielding; imaging workstations or X-ray viewboxes

Product specifications

Approx. dimensions (mm): 1000 x 750 x 1000

Approx. weight (kg): 300

Consumables: NA

Price range (USD): 30,000-240,000

Typical product life time (years): 8-10

Shelf life (consumables): NA

Types and variations

Digital, film



Monitor, Bedside, Electroencephalography

UMDNS

12602 Monitors, Bedside, Electroencephalography

GMDN

38736 Electroencephalographic monitoring system, portable

Other common names:

Cerebral function monitors; EEG recorders; electroencephalographs; monitors, bedside, electroencephalography, spectral

Health problem addressed

EEG monitors are used for observing and diagnosing a variety of neurologic conditions, including epilepsy, related convulsive disorders, and brain death. They can also be used to evaluate psychiatric disorders and differentiate among various psychiatric and neurologic conditions. In addition, electroencephalographic studies with EEG monitors can assist in localizing tumors or lesions on or near the surface of the brain.

Product description

EEG monitors use electrodes placed on a patient's scalp to measure, amplify, display in graphic form, and record the weak electrical signals generated by the brain. They continuously display processed EEG signals in graphic form over a period of time so that waveform and pattern changes can be readily detected. EEG monitors use computers to analyze and generate large amounts of electroencephalographic data (as in Fourier analysis), which are processed and displayed in various formats. Many systems can produce and display certain types of EPs or event-related potentials, a specific type of EEG signal that occurs in response to a periodically applied external stimulus.

Principles of operation

Low-amplitude (microvolt range) EPs believed to be generated by large numbers of nerve cells known as pyramidal cells, which are located in the outer layer (cortex) of the brain, polarize and depolarize in response to various stimuli, creating the EEG waveform. These fluctuating electrical potentials are detected by electrodes placed on the scalp and are displayed and/or recorded on the EEG. Each EEG channel amplifies a signal from a pair of electrodes, and these amplified signals can be printed on a chart recorder and/or displayed on a monitor.

Operating steps

Scalp electrodes are usually affixed by a technician with a conductive adhesive or paste. Cup, or disk, electrodes are affixed to the scalp with a special adhesive called collodion or with a conductive paste. Regardless of the electrode-placement procedure used, patients usually lie down, remain awake, and keep their eyes closed during an EEG recording; however, sleep EEG recordings (polysomnography) are also common. The set of electrode pairs that the technician selects for recording is called a montage.

Reported problems

The most common problem is improper electrode application. Avoiding this problem requires use of proper technique during skin preparation and electrode attachment, in addition to positioning the electrodes in the correct system configurations. Poor electrode contact with the scalp can distort the results of EEG recordings. A recurring difficulty with electroencephalography is the failure of EEG monitors to filter out artifacts, which can result in an incorrect signal interpretation or inability to analyze the EEG signal.



Use and maintenance

User(s): Neurologists, neurosurgeons, or other physicians, EEG technicians, sleep lab technicians, nurses, anesthesiologists, OR technicians,

Maintenance: Biomedical or clinical engineer/technician, medical staff, manufacturer/servicer

Training: Initial training by manufacturer, operator's manuals, user's guide

Environment of use

Settings of use: ICUs, OR, sleep lab, EEG lab, neurology clinics

Requirements: Uninterruptible power source, battery backup, good lead/cable connections, conductive gel

Product specifications

Approx. dimensions (mm): 350 x 50 x 390

Approx. weight (kg): 8

Consumables: Electrodes, conductive gel

Price range (USD): 1,750 - 113,000

Typical product life time (years): 8-10

Shelf life (consumables): NA

Types and variations

Computer laptop, mobile console, or monitor



Monitor, Central Station

UMDNS

20179 Monitors, Central Station

GMDN

38470 Patient monitoring system central station monitor

Other common names:

Central station monitors, central monitoring, alarm monitoring center, alarm monitoring station; Monitoring central

Health problem addressed

Continuous monitoring is a valuable tool that helps provide additional information to the medical and nursing staff about the physiologic condition of the patient. Using this information, the clinical staff can better evaluate a patient's condition and make appropriate treatment decisions and is used to treat a wide range of patient conditions.

Product description

Depending on their configuration, central monitors include modules to measure various parameters, including ECG, respiratory rate, NIBP and IBP, body temperature, SpO₂, SvO₂, cardiac output, ETCO₂, intracranial pressure, and airway gas concentrations. They include computing capabilities and additional displays to observe trend information; some also include full-disclosure capabilities. They do not replace bedside monitors.

Principles of operation

Physiologic monitors can be configured, modular, or both. Configured monitors have all their capabilities already built-in. Modular systems feature individual modules for each monitoring parameter or group of parameters; these modules can be used in any combination with each bedside monitor or be interchanged from monitor to monitor. Some physiologic monitoring systems have the capabilities of both modular and configured systems. With these monitors, frequently used parameters (e.g., ECG) are configured to the monitor, but modules As monitoring data is collected, some central stations are beginning to send the information to the patient's electronic medical record (EMR).

Operating steps

Receivers are connected to a bedside monitor and/or central station monitor. Some central station monitors can be networked so that a patient's waveform can be simultaneously displayed at multiple locations within a hospital. Some telemetry systems allow receivers to be connected to a bedside monitor or to be used on the same central station network as hardwired bedside monitors. This allows the clinician to view a patient's ECG and other monitored information at the bedside and at the central station.

Reported problems

Central monitors may tempt hospital personnel to pay more attention to the equipment than to the patient connected to it. Even monitors that are functioning reliably cannot substitute for frequent direct observation. Frequent false positive alarms can cause alarm fatigue and result in clinical staff missing critical patient events like low oxygen saturation levels.

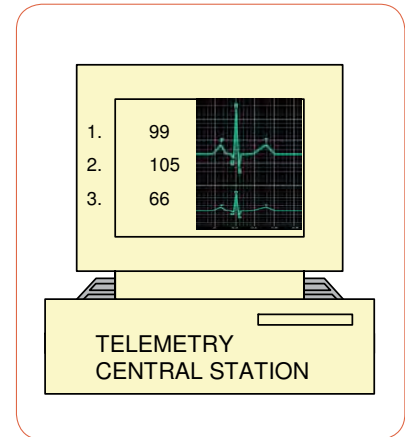

Use and maintenance

User(s): Physicians, nurses, other medical staff

Maintenance: Biomedical or clinical engineer/technician, medical staff, manufacturer/servicer

Training: Initial training by manufacturer, operator's manuals, user's guide

Environment of use

Settings of use: General medical and surgical areas, intermediate care/step down units, cardiac rehab, telemetry units

Requirements: Uninterruptible power source, redundant data backups

Product specifications

Approx. dimensions (mm): Varies by configuration selected

Approx. weight (kg): Varies by configuration selected

Consumables: None

Price range (USD): 4,500 - 40,000

Typical product life time (years): 7-10

Shelf life (consumables): NA

Types and variations

Desk mounted, bedside mounted



Monitoring System, Physiologic

UMDNS

12636 Monitoring Systems, Physiologic

GMDN

33586 Physiologic monitoring system, single-patient

36872 Transportable physiologic monitoring system

35569 Neonatal physiologic monitoring system

Other common names:

Operating room (OR) monitors, acute care monitoring systems, vital signs monitors, neonatal monitors, physiologic monitors; Single-patient monitoring system and related equipment; Measuring/monitoring system, biophenomena; Monitoring, bedside unit; Single patient monitoring system; Monitor, patient transport; Physiologic monitoring system, acute care, battery-powered; physiologic monitoring system, neonatal

Health problem addressed

Continuous monitoring is a valuable tool that helps provide additional information to the medical and nursing staff about the physiologic condition of the patient. Using this information, the clinical staff can better evaluate a patient's condition and make appropriate treatment decisions.

Product description

These systems usually include a central station monitor that receives, consolidates, and displays the information and a set of monitors that are deployed near the patient (bedside monitors) to provide the required data from each patient (ECG, respiratory rate, noninvasive blood pressure (NIBP) and invasive blood pressure (IBP) (systolic, diastolic, and mean), body temperature, (SpO₂), mixed venous oxygenation (SvO₂), cardiac output, (ETCO₂), intracranial pressure, and airway gas concentrations).

Principles of operation

Physiologic monitors can be configured, modular, or both. Configured monitors have all their capabilities already built-in. Modular systems feature individual modules for each monitoring parameter or group of parameters; these modules can be used in any combination with each bedside monitor or be interchanged from monitor to monitor. Some devices have the capabilities of both modular and configured systems. Many physiologic monitoring systems include a central station capable of displaying ECG waveforms and other information from any bedside within the system, and many are equipped with alarms that are coordinated with those at the bedside monitor.

Operating steps

Once patients are attached to the appropriate monitoring electrodes/pads, the cables are connected to the physiologic monitor. Then the monitor allows patients' physiologic parameters to be continuously monitored so that changes can be identified and, if necessary, treated. The monitored parameters can be seen at the bedside and (if desired) shared with a central station. System suppliers offer different monitoring options to meet a variety of applications (such as critical care, the operating room, or transport).

Reported problems

Poor electrode preparation and attachment are most commonly reported. Cables and lead wires should be periodically inspected for breaks and cracks. Loss of patient alarms, misleading alarms, and parameter errors have been the causes of most monitor recalls. Even monitors that are functioning reliably cannot substitute for frequent direct observation. Many devices produce frequent "false alarms" which can lead to alarm fatigue and missed critical events.



Use and maintenance

User(s): Physicians, nurses, other medical staff

Maintenance: Biomedical or clinical engineer/technician, medical staff, manufacturer/servicer

Training: Initial training by manufacturer, operator's manuals, user's guide

Environment of use

Settings of use: Hospital, inter- and intra-hospital transport; mostly in intermediate care/step down units and in general medical and surgical areas

Requirements: Uninterruptible power source, battery backup, good lead/pad/cable connections

Product specifications

Approx. dimensions (mm): 375 x 275 x 238

Approx. weight (kg): 10

Consumables: Batteries, cables, sensors/electrodes, cuffs

Price range (USD): 3,000 - 50,000

Typical product life time (years): 7-10

Shelf life (consumables): NA

Types and variations

Bedside mounted, pole mounted, wall mounted, transport, handle



Monitor, Telemetric, Physiologic

UMDNS

13987 Monitors, Telemetric, Physiologic

GMDN

31733 Electrocardiography telemetric monitoring system

Other common names:

Arrhythmia detectors, arrhythmia monitors, cardiac monitors, arrhythmia ECG monitors, telemetric ECG monitors, electrocardiographic monitors, ECG physiologic telemetry units, telemonitors; ECG telephonic transmission equipment; Monitor, telemetric, electrocardiography

Health problem addressed

Continuous monitoring is a valuable tool that helps provide additional information to the medical and nursing staff about the physiologic condition of the patient. Using this information, the clinical staff can better evaluate a patient's condition and make appropriate treatment decisions. Most commonly used for treatment of patients with cardiac conditions.

Product description

Telemetric monitors designed for continuous measurement and transmission of several vital physiologic parameters to a central station or a bedside monitor. These monitors typically consist of transmitters and electrodes, an antenna system or access points, receivers, and a display screen and recorder. Telemetry systems transmit physiologic parameters like ECG, NIBP, SpO₂.

Principles of operation

Telemetric monitoring systems transmit patients' physiologic parameters to a central station display and/or a bedside monitor. Data transfer is done to a remote location by means of radio waves. Because they use radio-wave transmission, cables are not required to connect the patient and transmitter to the display monitor, thereby allowing greater patient mobility.

Operating steps

Appropriate monitoring electrode must be attached to the patient. The cables are attached to the telemetry transmitter. The transmitter sends physiologic monitored data to the central station or bedside monitor that receives, consolidates, and displays the information collected from one or more patients.

Reported problems

The frequency bands used by wireless medical telemetry are getting crowded, putting medical telemetry at risk for interference. Signal fading, during which the ECG signal is momentarily lost, results in inaccurate ECG signals, false alarms, and monitoring data loss. To reduce the potential of interference from noise, hospitals should survey the installation site to ensure that the antennae are properly placed, that no other equipment operates at that frequency, and that no outside interference impede telemetry signals.

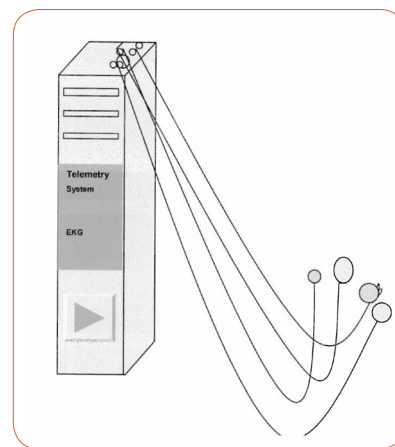

Use and maintenance

User(s): Physicians, nurses, other medical staff

Maintenance: Biomedical or clinical engineer/technician, medical staff, manufacturer/servicer

Training: Initial training by manufacturer, operator's manuals, user's guide

Environment of use

Settings of use: Hospital; step-down/intermediate care areas, cardiac rehab, any area with mobile patients that require physiologic monitoring

Requirements: Uninterruptible power source, battery backup, good lead/pad/cable connections

Product specifications

Approx. dimensions (mm): 124 x 70 x 35

Approx. weight (kg): 0.18

Consumables: Batteries, cables, sensors/electrodes

Price range (USD): 2,300 - 150,000

Typical product life time (years): 7-10

Shelf life (consumables): NA

Types and variations

Telemetry pack worn by patient (e.g., pendant, strapped to arm, garment pouch)

Peritoneal Dialysis Unit

UMDNS

11226 Peritoneal Dialysis Units

GMDN

11226 Peritoneal dialysis system

Other common names:

Artificial Kidney Machines; Cyclers, Peritoneal Dialysis; Dialysis Machines; Dialysis Units; Kidney Machines; Peritoneal Dialysis Cyclers; PD Cyclers; Peritoneal Dialysis Drainage Systems; Automated peritoneal dialysis apparatus; System, peritoneal, automatic delivery; Dialysis system, peritoneal

Health problem addressed

These devices are intended to treat renal failure, partially replacing kidney function by removing metabolic wastes through selective diffusion across the peritoneum.

Product description

These devices consist of a machine that performs automated dialysis cycles (for CCPD), a catheter and a sterile disposable tubing system.

Principles of operation

These devices perform three main types of PD therapy: continuous ambulatory peritoneal dialysis (CAPD), intermittent peritoneal dialysis (IPD), and continuous cyclic peritoneal dialysis (CCPD). The type of therapy indicated depends on the physician's preference and proficiency in the required aseptic technique as well as on the patient's condition. The most commonly used type of therapy is CAPD, in which the patient manually infuses dialysate from a portable plastic bag that is usually worn until the dialysate is drained several hours later. CAPD is inexpensive and can be performed almost anywhere if strict aseptic technique is used. IPD can be performed manually by the patient, a family member, or a nurse; it can also be performed automatically with a PD unit.

Operating steps

A typical dialysis cycle consists of filling the peritoneal cavity with a volume of dialysate, letting the dialysate remain within the cavity for a selected period of time (dwell time) while diffusion and osmosis occur, and draining the spent dialysate from the peritoneal cavity.

Reported problems

Peritonitis (inflammation of the peritoneum) is the most serious complication of PD therapy. Poor aseptic technique often introduces bacteria that are present on the hands or on the skin surrounding the catheter site to the PD tubing, which can result in peritonitis and catheter-site or tunnel infections. User error has resulted in the accidental introduction of disinfectant into the peritoneal cavity. Also, arthritic or very weak patients may have difficulty handling the tubing sets and drainage equipment.

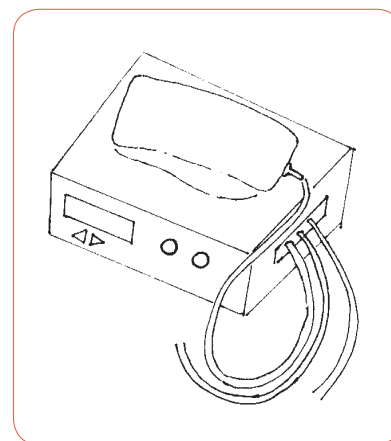

Use and maintenance

User(s): Patient

Maintenance: Medical staff; technician; biomedical or clinical engineer

Training: Initial training by dialysis department staff

Environment of use

Settings of use: Hospital; dialysis clinic; home

Requirements: Stable power source (if using continuous cycler-assisted peritoneal dialysis)

Product specifications

Approx. dimensions (mm): 215 x 455 x 385

Approx. weight (kg): 17

Consumables: Dialysate and administration sets

Price range (USD): 7,000 - 13,000

Typical product life time (years): 5 -7

Shelf life (consumables): variable and single use

Types and variations

Continuous ambulatory peritoneal dialysis (CAPD); continuous cycler-assisted peritoneal dialysis (CCPD)

Pulmonary function analyzer

UMDNS

13182 Analyzers, Physiologic, Respiratory Function Mechanics, Adult

GMDN

35282 Pulmonary function analysis system, adult

Other common names:

Respiratory function analyzers; respiratory function mechanics analyzers; Calculator, pulmonary function laboratory

Health problem addressed

Pulmonary function analyzers measure the performance of a patient's respiratory system, especially for outpatient or presurgical screening. These systems measure the ventilation, diffusion, and distribution of gases in the lungs. They are used to help assess patients with conditions like chronic obstructive pulmonary disorder (COPD).

Product description

Pulmonary function analyzers are designed to assess the volume, airflow, and derived parameters through the respiratory tract of adults and older children. These devices typically include a spirometry instrument (e.g., pneumotachometer, bellows, rolling-seal-type spirometer), a computer, a gas analyzer, and an electronic unit with computerized capabilities and appropriate software. In addition to diagnostic spirometer measurements, they may measure parameters such as functional residual capacity, diffusing capacity of the lungs for carbon monoxide, and airway resistance. The analyzers are intended to provide a baseline for ventilatory function as well as identify respiratory impairments. Some systems include a total-body plethysmograph for measuring lung volume and Raw.

Principles of operation

Spirometry instruments measure the volume of gases exhaled by the patient (i.e., volume changes of the lungs) either by volume displacement or flow sensing methods. Spirometers measure the volume directly; these devices include water-seal bellows and rolling-seal spirometers, or the flow of gas that is integrated to yield volume. Such flow sensing instruments can employ a pneumotachometer, a hot-wire anemometer, or a turbinometer. Some analyzers incorporate computers with software that permits customized reports or the inclusion of specialized predictive equations for normal function.

Operating steps

The operator selects the desired parameters to be measured or follows a procedure protocol; a spirometry instrument is held to the patient's mouth in order to measure exhaled breath. Results are displayed onscreen and may be stored or printed out.

Reported problems

Computer software can be a significant source of error, and a manufacturer should be able to document the computational algorithms of its software and demonstrate its accuracy. Problems related to equipment failures of spirometers are uncommon; some may result from misuse of a properly functioning analyzer. The mouthpiece or tubing on a spirometry instrument can provide a warm, moist environment favorable to the growth and transmittal of disease-causing microorganisms.

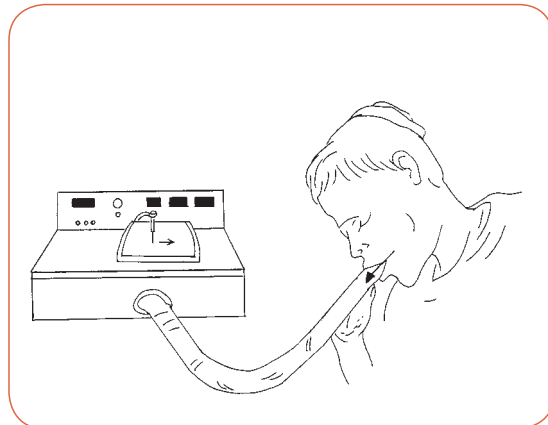

Use and maintenance

User(s): Physicians, nurses, other medical staff

Maintenance: Biomedical or clinical engineer/technician, medical staff, manufacturer/servicer

Training: Initial training by manufacturer, operator's manuals, user's guide

Environment of use

Settings of use: Pulmonary medicine, respiratory therapy, or general medicine departments

Requirements: Uninterruptible power source, battery backup, appropriate masks and tubing

Product specifications

Approx. dimensions (mm): 350 x 600 x 1,000

Approx. weight (kg): 50

Consumables: Tubing, masks

Price range (USD): 1,800 - 60,000

Typical product life time (years): 8

Shelf life (consumables): NA

Types and variations

Portable, cart, desktop, tabletop



Radiographic, Fluoroscopic System

UMDNS

16885 Radiographic/Fluoroscopic Systems, General-Purpose

GMDN

37645 Stationary basic diagnostic x-raysystem, digital

Other common names:

General-Purpose Radiographic/Fluoroscopic Systems; Radiographic/Fluoroscopic Units, General-Purpose; Tables, Radiographic/Fluoroscopic; Direct-Controlled Radiographic/Fluoroscopic Systems; Remote-Controlled Radiographic/Fluoroscopic Systems

Health problem addressed _____

This technology is effective in arthrography, bronchography, gastrointestinal and biliary tree studies, hysterosalpingography, intravenous and retrograde pyelography, myelography, and sialography. Other applications include locating ingested foreign materials; localizing lesions for needle aspiration or biopsy; highlighting congenital anatomic abnormalities; diagnosing congestive heart failure; and evaluating chest pain.

Product description _____

These devices consist of a combination of a patient support unit (usually a table base and a movable tabletop), an under-table x-ray tube and holder, x-ray generators, a power-assisted spot-film device, an image intensifier, radiation shields, a Bucky film tray, an overhead x-ray tube and ceiling support for follow-up radiography, and a control panel.

Principles of operation _____

Most R/F systems allow spot filming of the image to produce an x-ray film for later detailed study by the radiologist and for film archiving. For routine radiography and follow-up x-ray scans after studies that use contrast media (e.g., gastrointestinal studies), most systems include an under-table Bucky tray for use with an overhead x-ray tube.

Operating steps _____

Patients are positioned on the x-ray table and a catheter inserted (procedure-dependent). The x-ray scanner will be used to produce fluoroscopic images. Depending on the procedure, a dye or contrast substance may be injected into the patient via an IV line in order to better visualize the organs or structures being studied. After the procedure is complete the IV line will be removed.

Reported problems _____

Typical problems include mechanical issues; unexpected failures of safety features; overexposure or unexpected exposure to radiation; breakage or weakening of mechanical supports; overheating in drive motors; table misalignments; inadequate radiation shielding; and noncompliance with regulatory codes.



Use and maintenance _____

User(s): Radiologic technician

Maintenance: Medical staff; technician; biomedical or clinical engineer

Training: Initial training by manufacturer and manuals

Environment of use _____

Settings of use: Hospitals; private practices; clinics; stand-alone imaging centers

Requirements: Radiation shielding (room, mobile, or overhead); stable power source

Product specifications _____

Approx. dimensions (mm): Configurable

Approx. weight (kg): Configurable

Consumables: NA

Price range (USD): 415,000 - 1,150,000

Typical product life time (years): 10

Shelf life (consumables): NA

Types and variations _____

Over- or under-table x-ray tube; C-arm; remote control; direct control



Radiotherapy Planning System

UMDNS

21955 Workstations, Radiotherapy Planning

GMDN

40996 Radiation therapy treatment planning system

Other common names:

Computers, Radiotherapy Planning System; Computers, Radiotherapy Treatment Planning; Computers, Radiotherapy, Planning; Radiotherapy Planning Workstations; Radiotherapy Treatment Planning Systems; Treatment Planning Systems; Radiotherapy, dose planning system; System, planning, radiation therapy treatment.

Health problem addressed _____

These systems are used mainly for treatment of cancer and related diseases.

Product description _____

Computer workstations that typically consist of a computer, software for dosage calculation, and input and output devices (e.g., keyboards, monitors, printers) for graphic and alphanumeric data. These systems use x-ray image data and dosimetric data to help clinicians determine the optimum treatment parameters to match the prescribed dose and constraints. Planning systems are available for all types of radiation treatment delivery.

Principles of operation _____

Various computer algorithms are used to model the interactions between the radiation beam and the patient's anatomy to determine the spatial distribution of the radiation dose. Different algorithms are necessary to account for the different types of radiation and computational complexity. With the increase in computational performance available today, improved algorithms are being developed. All treatment planning systems use x-ray based image data since the x-ray data is necessary for the dosimetry calculations. Most treatment planning systems today use inverse planning, which works backwards from the prescribed treatment volume to determine the optimum beam angles and collimation.

Operating steps _____

The first step in treatment planning is to identify the planning target volume and the organs at risk. This is done by the oncologist using the contouring tools available on the planning system. Automatic contouring tools can help in outlining organs or regions of bulk density. Depending on the type of lesion, it may be necessary to use multiple images from different sources. Alignment can be achieved using either implanted fiducial markers or anatomic structures. Dose calculation is central to all treatment planning systems.

Reported problems _____

Several issues have been reported involving treatment delivery errors due to incorrect calibration among third-party equipment, treatment planning systems, and treatment delivery equipment. These errors can affect multiple patients. Therefore, all those involved in radiation oncology should be alert to any anomalies.

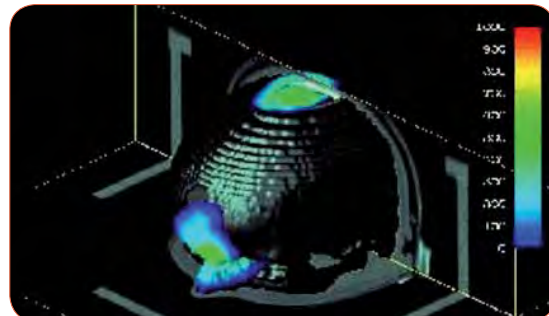

Use and maintenance _____

User(s): Medical physicists

Maintenance: Medical staff; technician; biomedical or clinical engineer

Training: Initial training by manufacturer and manuals

Environment of use _____

Settings of use: Hospitals; private practices; clinics; stand-alone imaging centers

Requirements: Stable power source

Product specifications _____

Approx. dimensions (mm): NA

Approx. weight (kg): NA

Consumables: NA

Price range (USD): 50,000 - 230,000

Typical product life time (years): 5 to 7

Shelf life (consumables): NA

Types and variations _____

Radiosurgery planning systems; brachytherapy planning systems



Radiotherapy Systems

UMDNS

16972 Radiotherapy Systems, Cobalt;
12364 Linear Accelerator

GMDN

38297 Teletherapy radionuclide system; Linear
35159 accelerator system

Other common names:

Radiotherapy systems, external beam radiation therapy systems, radiation therapy systems, LINAC; Cobalt radiotherapy machine; Radioisotope teletherapy equipment; Radiotherapy unit, cobalt; Radionuclide system, therapeutic, teletherapy; Medical linear accelerator

Health problem addressed

Linear accelerators (linacs) and cobalt radiotherapy units are used in external-beam radiation therapy to treat cancer. Cobalt units and low-energy linacs are used primarily to treat bone cancer and tumors of the head, neck, and breast. High-energy linacs are used to treat deep-seated neoplasms and tumors of the pelvis and thorax. Radiation is used to treat at least 50% of all cancer cases. It can be either curative or palliative, depending on the stage and prognosis of the disease.

Product description

Linacs emit a well-defined beam of uniformly intense x-ray photon radiation of different energies, depending on the accelerator. Some linacs also produce electron beams. Cobalt radiotherapy units use a man-made radioisotope, cobalt-60, to produce gamma-ray photons. Linacs consist of four major components—a modulator, an electron gun, a radio-frequency (RF) power source, and an accelerator guide. The electron beam produced by a linac can be used for treatment or can be directed toward a metallic target to produce x-rays. Linacs are classified according to their energy levels, low, medium, and high.

Principles of operation

Linear accelerators accelerate electrons that collide with a heavy metal target, scattering high-energy x-rays. A portion of these x-rays is collected and shaped to form a beam that matches the patient's tumor. The beam comes out of a gantry which rotates around the patient. The patient lies on a moveable treatment couch and lasers are used to make sure the patient is in the proper position. Radiation can be delivered to the tumor from any angle by rotating the gantry and moving the treatment couch.

Operating steps

A radiation therapist positions the patient on the unit's table and carefully aligns the patient with positioning lasers and fiducial tattoos. Additional beam shaping elements are attached to the collimator or are adjusted on the collimator. The therapist then leaves the room and controls the delivery of radiation from a separate control room.

Reported problems

Most radiation therapy-related errors and incidents have been reported to be caused by use error. This can result in significant under-dose or over-dose in the delivery of radiation. Errors can also occur at the planning stage or in equipment calibration. Missed clinical information at the planning stage has caused severe (even fatal) radiation injury, and poor calibration can lead to serious medical errors. Also, in several reported cases, electromagnetic interference from a linear accelerator caused infusion-pump failure when the pumps were being used on patients undergoing radiation therapy.

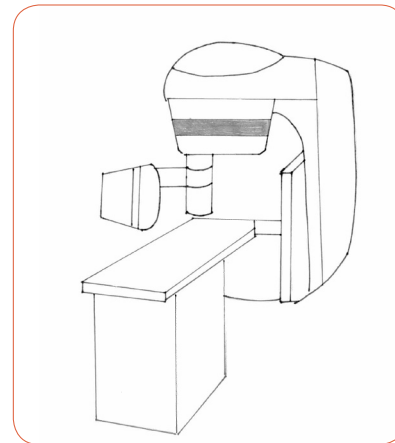

Use and maintenance

User(s): Medical physicists; radiation therapy technicians

Maintenance: Medical physicists; radiation therapy staff; technicians; biomedical or clinical engineer

Training: Initial training by manufacturer and manuals

Environment of use

Settings of use: Radiation therapy department or centers

Requirements: Stable power source; shielded room and control room

Product specifications

Approx. dimensions (mm): 6500 x 7000 x 3200 (room size); 2500 x 500 (treatment couch)

Approx. weight (kg): Variable

Consumables: NA

Price range (USD): 1,500,000-4,500,000

Typical product life time (years): 8-10

Shelf life (consumables): NA

Types and variations

Linear accelerators; Cobalt radiotherapy units



Remote-afterloading brachytherapy system

UMDNS

20352 Brachytherapy Systems
17517 Brachytherapy Systems, Remote Afterloading

GMDN

38300 Remote-afterloading brachytherapy system

Other common names:

Curietherapy Systems; Endocurietherapy Systems; Radiotherapy Units; Remote Afterloaders; Radionuclide system, therapeutic, brachytherapy, remote afterloading; System, applicator, radionuclide, remote-controlled

Health problem addressed

These devices are most commonly used in conjunction with external-beam radiotherapy, surgery, or chemotherapy to treat endometrial, cervical, prostate, or pancreatic cancer; they are also the primary treatment for soft-tissue sarcomas, vaginal and rectal cancers, early-stage lip and tongue cancers, and endobronchial carcinomas.

Product description

These systems are typically radioisotope delivery units (i.e., afterload unit) with a source-drive mechanism (usually a computer-controlled stepper motor with drive rollers or belts), applicators, a control console, and a computerized planning unit.

Principles of operation

Remote afterloading brachytherapy systems automatically administer a radioisotope directly to cancerous tissue, thereby minimizing the radiation dose to surrounding tissue and eliminating the radiation exposure to hospital staff. The amount of the radiation dose varies with the brachytherapy method chosen for treatment delivery: low-dose-rate (LDR) brachytherapy uses an implanted source that delivers a dose of 40 to 60 centigrays (cGy) per hour over several days; high-dose-rate (HDR) brachytherapy uses a traveling (stepping) source that delivers a dose greater than 100 cGy per minute for 5 to 30 minutes; pulsed-dose-rate (PDR) brachytherapy uses a cable-driven source delivering a dose of up to about 300 cGy per hour for 10 to 30 minutes, repeated over several days.

Operating steps

After the treatment parameters have been tested, the source drive mechanism, usually a computer-controlled stepper motor with drive rollers or belts, advances the source from the shielded safe through the guide tubes and into the treatment applicators. The source guide tubes, also called transfer tubes, ensure accurate source placement in the applicators. The indexer, which typically provides 18 to 24 channels, facilitates source entry and transfer for complex treatments requiring multiple applicators.

Reported problems

Most of the problems associated with brachytherapy are side effects of radiation. Patients may develop localized irritation, soft-tissue ulcerations, osteonecrosis, small-bowel perforations, radiation mucositis, and abdominal fistulas from implanted radioactive sources. There have also been reports of dose miscalculations and improper handling of source wires and seeds by physicians, nurses, and medical physicists during brachytherapy treatment.

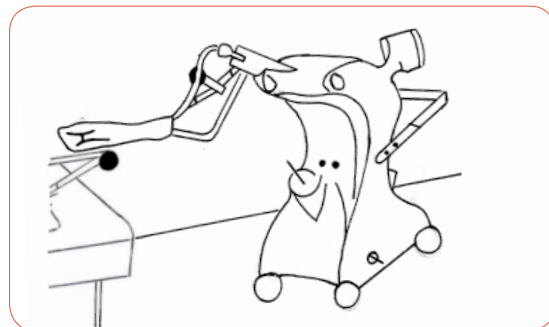

Use and maintenance

User(s): Radiation physicist; licensed dosimetrist (supervised by radiation physicist); radiation oncologist

Maintenance: Medical staff; technician; biomedical or clinical engineer

Training: Initial training by manufacturer and manuals

Environment of use

Settings of use: Hospital radiation oncology department

Requirements: Stable power source; shielding for treatment room and control room

Product specifications

Approx. dimensions (mm): 1330 x 540 x 790

Approx. weight (kg): 92

Consumables: NA

Price range (USD): 255,000 - 485,124

Typical product life time (years): 8 to 10

Shelf life (consumables): NA

Types and variations

High-dose-rate (HDR) brachytherapy; low-dose-rate (LDR) brachytherapy; pulsed-dose-rate (PDR) brachytherapy systems



Scanning System, CT

UMDNS

13469 Scanning Systems, Computed Tomography

GMDN

37618 Full-body CT system

Other common names:

Computed Tomography Scanners; Computed Tomography Scanning Systems; Computed X-Ray Tomography Scanners; Computer-Assisted Tomography Scanners; Computerized Tomographs; CT Scanners; CT Scanners, Mobile; CT Scanning Systems; CT Slice Scanners; Multislice Scanners, Computer Tomography; Scanners, Computed Axial Tomography; Scanners, Computed Tomography; Scanners; Computer Tomography, Mobile; Scanners, Computed Tomography, X-Ray; Scanner, computed tomography, full-body; Whole body x-ray CT scanner

Health problem addressed _____

These scanners are used for a wide variety of diagnostic procedures, including spine and head injuries, lesions, and abdominal and pelvic malignancies; to examine the cerebral ventricles, the chest wall, and the large blood vessels; and to assess musculoskeletal degeneration.

Product description _____

Devices that consist of an x-ray subsystem, a gantry, a patient table, and a controlling computer. A high-voltage x-ray generator supplies electric power to the x-ray tube, which usually has a rotating anode and is capable of withstanding the high heat loads generated during rapid multiple-slice acquisition. The gantry houses the x-ray tube, x-ray generator, detector system, collimators, and rotational frame.

Principles of operation _____

CT scanners use slip-ring technology, which was introduced in 1989. Slip-ring scanners can perform helical CT scanning, in which the x-ray tube and detector rotate around the patient's body, continuously acquiring data while the patient moves through the gantry. The acquired volume of data can be reconstructed at any point during the scan. All modern CT scanners are multislice. Inside the gantry, an x-ray tube projects a fan-shaped x-ray beam through the patient to the detector array. As the x-ray tube and detector rotate, x-rays are detected continuously through the patient. The computer mathematically reconstructs data from each full rotation to produce an image of one slice.

Operating steps _____

During a CT scan, the table moves the patient into the gantry and the x-ray tube rotates around the patient. As x-rays pass through the patient to the detectors, the computer acquires and processes data to form an image.

Reported problems _____

Controlling the radiation dose is the most significant concern facing all CT users. Also, unnecessary testing could cause an overexposure to radiation. System problems and communication breakdowns can result in repeat CT scans, and so, facilities need to provide extensive training for these systems to eradicate confusion when using the equipment.



Use and maintenance _____

User(s): Computed tomography scanning technician

Maintenance: Medical staff; technician; biomedical or clinical engineer

Training: Initial training by manufacturer and manuals

Environment of use _____

Settings of use: Hospitals; private practices; clinics; stand-alone imaging centers

Requirements: Stable power source; shielded room and control room

Product specifications _____

Approx. dimensions (mm): 1882 x 2225 x 1006

Approx. weight (kg): 1906

Consumables: NA

Price range (USD): 329,900-3,200,000

Typical product life time (years): 8 to 10

Shelf life (consumables): NA

Types and variations _____

Multislice; 3-D CTA; 4-D imaging



Scanning System, Magnetic Resonance Imaging, Full-Body

UMDNS

18108 Scanning Systems, Magnetic Resonance Imaging, Full-Body

GMDN

37652 Full-body MRI system, permanent magnet
37653 Full-body MRI system, resistive magnet
37654 Full-body MRI system, superconducting magnet

Other common names:

MRI systems; MRI scanners, MR scanners, magnetic resonance scanners

Health problem addressed

MRI is primarily used to identify diseases of the central nervous system, brain, and spine and to detect musculoskeletal disorders. It is also used to view cartilage, tendons, and ligaments. MRI can also be used to image the eyes and the sinuses. MRI can be used to help diagnose infectious diseases; to detect metastatic liver disease; to display heart-wall structure; to stage prostate, bladder, and uterine cancer; to evaluate kidney transplant viability; and to study marrow diseases.

Product description

An MRI unit consists of a magnet, shimming magnets, an RF transmitter/receiver system with an antenna coil, a gradient system, a patient table, a computer, display monitors, and an operator console. They typically have static magnetic fields ranging from 0.064 to 3.0 T (as measured in the center of the magnet bore). For comparison, the earth's magnetic field is approximately 0.00006 T. Three basic magnet designs are available for diagnostic MRI applications: the permanent magnet, the resistive magnet, and the superconducting magnet. Most systems today use a superconducting magnet. A standard MRI suite comprises three main rooms: the procedure room, the equipment room, and the control room.

Principles of operation

MRI units use strong electromagnetic fields and radio-frequency radiation to translate the distribution of hydrogen nuclei in body tissue into computer-generated images of anatomic structures. MRI depends on the magnetic spin properties of certain atomic nuclei in body tissue and fluids and their behavior in the applied magnetic field. These nuclei are normally aligned randomly in tissue until an external magnetic field is applied and the nuclei align themselves with that field.

Operating steps

During an MRI scan the patient is moved into the bore of the MRI magnet while the operator adjusts the controls depending on the section(s) of the anatomy being scanned. Before the procedure begins patients are checked for metal jewelry or other metal objects which can distort the image or cause injury. Images are processed by the MRI system's computer and are generated for viewing and diagnosis. Images are typically transferred to a picture archiving and communication system.

Reported problems

Although the number of adverse incidents is relatively low, numerous reports of injuries in MRI centers and a few reports of deaths. Most of these incidents can be attributed to the presence of ferromagnetic devices and equipment (including implants) in the MR environment. Ferromagnetic objects have



become projectiles and injured or killed patients. Several incidents have occurred in which patients undergoing MRI studies sustained second- and third-degree burns when their skin contacted surface coils or monitoring cables.

Use and maintenance

User(s): Radiologists, MRI technicians

Maintenance: Medical staff; technician; biomedical or clinical engineer

Training: Initial training by manufacturer and manuals

Environment of use

Settings of use: MRI suite or clinic; operating room

Requirements: Stable power source; shielded room and control room

Product specifications

Approx. dimensions (mm): 2500 x 2500 x 2500

Approx. weight (kg): 5,500

Consumables: NA

Price range (USD): 150,000 - 3,100,000

Typical product life time (years): 8-10

Shelf life (consumables): NA

Types and variations

Extremity, full body, mammographic, neurosurgical; various field strength systems; open or closed



Scanning System, Ultrasonic

UMDNS

15976 Scanning Systems, Ultrasonic, General-Purpose

GMDN

40761 General-purpose ultrasound imaging system

Other common names:

Abdominal Ultrasound Scanners; Doppler Devices; General-Purpose Ultrasonic Scanners; Metal Detectors; Metal Detectors, Ultrasonic; Scanners, Ultrasonic, Dedicated Linear Array; Scanners, Ultrasonic, General-Purpose; Scanners, Ultrasonic, Pediatric; Ultrasound Scanners, Bladder; Ultrasound Scanners, General-Purpose; Ultrasound Scanners, Urology; Diagnostic imaging equipment, general use

Health problem addressed

These devices are used primarily for abdominal and OB/GYN scanning. Some systems include additional transducers to facilitate more specialized diagnostic procedures, such as cardiac, vascular, endovaginal, endorectal, or small-parts (e.g., thyroid, breast, scrotum, prostate) scanning.

Product description

General-purpose ultrasonic scanning systems provide two-dimensional (2-D) images of most soft tissues without subjecting patients to ionizing radiation. These systems typically consist of a beamformer, a central processing unit, a user interface (e.g., keyboard, control panel, trackball), several probes (transducers or scanheads), one or more video displays, some type of recording device, and a power system.

Principles of operation

Ultrasound refers to sound waves emitted at frequencies above the range of human hearing. For diagnostic imaging, frequencies ranging from 2 to 15 megahertz (MHz) are typically used. Ultrasonic probes contain one or more elements made of piezoelectric materials (materials that convert electrical energy into acoustic energy and vice versa). When the ultrasonic energy emitted from the probe is reflected from the tissue, the transducer receives some of these reflections and reconverts them into electrical signals. These signals are processed and converted into an image. Lower sound frequencies provide decreased resolution but greater tissue penetration, while higher frequencies improve resolution when deep penetration is not necessary.

Operating steps

To perform ultrasonic imaging, a probe is either placed on the skin (after an acoustic coupling gel is applied) or inserted into a body cavity. Scanned structures can be measured by ultrasound technicians using digital calipers (i.e., cursors electronically superimposed over the scanned cross-sectional image that calculate the size of the scanned structure). The caliper system can also be used by technicians to plot and measure the area, circumference, or volume of a structure. A data-entry keyboard permits information such as patient name, date, and type of study to be entered and displayed along with the scanned image.

Reported problems

Ultrasound diagnostic imaging appears to be risk-free when used properly. Ultrasound transducers should be handled carefully to avoid damage. Electromechanical problems, such as cracks in piezoelectric elements, can alter beam width and/or spatial pulse length, thereby affecting lateral and axial resolution. Errors in distance measurements can cause incorrect calculations.



Use and maintenance

User(s): Ultrasound technician

Maintenance: Medical staff; technician; biomedical or clinical engineer

Training: Initial training by manufacturer and manuals

Environment of use

Settings of use: Hospital radiology departments; private physician offices

Requirements: Stable power source

Product specifications

Approx. dimensions (mm): 1340x420x630

Approx. weight (kg): 75

Consumables: NA

Price range (USD): 25,000 -220,000

Typical product life time (years): 5

Shelf life (consumables): NA

Types and variations

General-purpose; OB/GYN; small parts; vascular; cardiology; endocavity



Transcutaneous Blood Gas Monitor

UMDNS

17996 Monitors, Bedside, Blood Gas, Transcutaneous

GMDN

36898 Patient monitoring system module, blood gas, transcutaneous

Other common names:

TcpCO₂ monitor, breathing circuit monitor, CO₂ monitor

Health problem addressed

Monitors partial pressure of CO₂ at the skin surface of patients at risk of hypoxia or inadequate ventilation or in whom clinically significant metabolic changes may be detected as changes in tcpCO₂ (e.g., patients under general anesthesia, patients with emphysema). Transcutaneous blood gas monitoring can be used as a supplement—or, in some cases, as an alternative—to periodically drawing and analyzing arterial blood.

Product description

Rectangular or square device with wires connecting to patient measurement sensors; additional input/output channels may be available; display (LED, LCD) indicates patient blood gas levels; buttons or dials for control settings; may include thermal printer; sensors are usually small and round, attached to patient's skin with adhesive.

Principles of operation

TcpCO₂ is monitored by a small sensor, which houses a pH electrode, a reference electrode, an electrolyte solution, a Teflon membrane, and a heating element. An adhesive ring fastens the sensor to the skin. The heating element warms the skin to 42° to 45°C. The CO₂ that diffuses through the stratum corneum by the warming of the skin passes across the sensor's semipermeable membrane and into a diluted bicarbonate solution (electrolyte solution) in the sensor chamber. Adding CO₂ lowers the pH of the solution (increases acidity); a glass electrode measures the change. The electrode's output is converted into a signal, which the instrument records as tcpCO₂.

Operating steps

Sensors are affixed to patient skin; device is programmed by operator (i.e., turned on, measured parameters may be chosen); device takes periodic or continuous blood gas measurements and alarms if measurements are outside of normal range. Periodically location of sensor must be changed to a different place on patient's skin to avoid irritation or burns, some devices include a site-change timer.

Reported problems

Varying degrees of burns can result from the sensor's elevated temperature. Thin-skinned infants and patients with peripheral vascular impairment are especially at risk. Frequent sensor relocation, as recommended by the manufacturer, can help prevent burns; however, sensor relocation often entails recalibration.

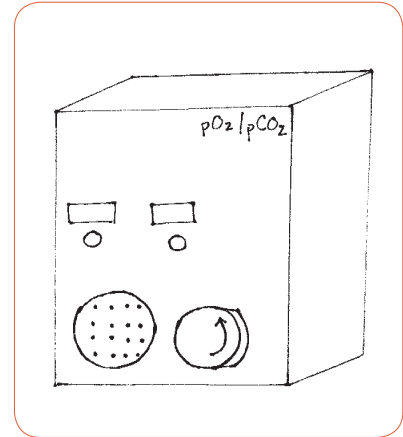

Use and maintenance

User(s): Medical staff

Maintenance: Biomedical or clinical engineer

Training: Initial training by manufacturer and manuals

Environment of use

Settings of use: Hospital

Requirements: Line power

Product specifications

Approx. dimensions (mm): 100 x 300 x 200

Approx. weight (kg): 0.5-5

Consumables: Sensors, probes, calibration materials

Price range (USD): 7,225 - 20,000

Typical product life time (years): 8

Shelf life (consumables): Disposable sensor membranes: 2 weeks; reusable sensors: 2 months

Types and variations

Modular unit (connected to other patient monitoring devices) or stand-alone; specialized for adult, pediatric, or neonate; most measure both tcpCO₂ and tcpO₂; some measure tcpCO₂ and SpO₂; reusable or disposable sensors



Ventilator, Intensive Care

UMDNS

17429 Ventilators, Intensive Care

GMDN

42411 Intensive-care ventilator, adult/infant

Other common names:

IC ventilators, critical care ventilators, continuous ventilators, positive-pressure ventilators; Adult ventilator; Respirator, general-purpose

Health problem addressed

Ventilators provide temporary ventilatory support or respiratory assistance to patients who cannot breathe on their own or who require assistance to maintain adequate ventilation because of illness, trauma, congenital defects, or drugs (e.g., anesthetics).

Product description

Ventilators consist of a flexible breathing circuit, a control system, monitors, and alarms. The gas is delivered using a double-limb breathing circuit. The gas may be heated or humidified using appropriate devices. The exhalation limb releases the gas to the ambient air. Intensive care ventilators are usually connected to a wall gas supply. Most ventilators are microprocessor controlled and regulate the pressure, volume, and FiO₂. Power is supplied from either an electrical wall outlet or a battery.

Principles of operation

The control mode provides full support to patients who cannot breathe for themselves. In this mode, the ventilator provides mandatory breaths at preset time intervals and does not allow the patient to breathe spontaneously. Assist/control modes also provide full support by delivering an assisted breath whenever the ventilator senses a patient's inspiratory effort and by delivering mandatory breaths at preset time intervals. With volume-controlled breaths, a control system is used to ensure that a set tidal volume is delivered during the inspiratory cycle. Pressure-controlled breaths regulate flow delivery to attain and sustain a clinician-set inspiratory pressure level for a set time so that the ventilator delivers controlled or assisted breaths that are time cycled. Combination modes are also available.

Operating steps

Users first check that the unit is ready for use (e.g., run performance and calibration checks). They next make sure that settings (including alarm levels) are correct and appropriate for the patient type and condition. Once completed, the patient is connected to the ventilator. When the ventilator-patient connection is completed, users ensure the patient is being properly ventilated. While patient is being ventilated, caregivers monitor/evaluate the patient, and respond promptly to alarms.

Reported problems

Risk of acquiring pneumonia may be minimized by following proper infection control procedures. Leaks in the breathing circuit or components may prevent the ventilator from delivering the appropriate amount of ventilation. Proper maintenance and avoiding operator errors or machine failures can be critical. Critical changes in patient conditions can be missed if alarms are not set properly or are not noted by clinical staff.



Use and maintenance

User(s): Physicians, nurses, respiratory therapist, other medical staff

Maintenance: Biomedical or clinical engineer/technician, medical staff, manufacturer/servicer

Training: Initial training by manufacturer, operator's manuals, user's guide

Environment of use

Settings of use: Intensive care, critical care settings, surgery

Requirements: Uninterruptible power source, battery backup, proper tubing/masks

Product specifications

Approx. dimensions (mm): 125 x 40 x 62

Approx. weight (kg): 67

Consumables: Batteries, tubing, masks, filters

Price range (USD): 9,000 - 60,000

Typical product life time (years): 8, depends on hours used

Shelf life (consumables): NA

Types and variations

Cart or stand mounted



Ventilator, Intensive Care, Neonatal/Pediatric

UMDNS

14361 Ventilators, Intensive Care, Neonatal/Pediatric

GMDN

14361 Intensive-care ventilator, neonatal/paediatric

Other common names:

Continuous ventilators, neonatal ventilators, pediatric ventilators, positive-pressure ventilators, time-cycled ventilators; Ventilator, infant

Health problem addressed

Neonatal intensive care ventilators provide ventilatory support to preterm and critically ill infants who suffer from respiratory failure and who generally have low-compliance lungs, small tidal volumes, high airway resistance, and high respiratory rates. These mechanical ventilators promote alveolar gas exchange (oxygenation and carbon dioxide [CO₂] elimination) by generating positive pressure to inflate the lungs of an infant who is incapable of adequate independent breathing.

Product description

A typical neonatal ventilator system consists of a breathing circuit, a humidification system, gas-delivery systems, monitors and their associated alarms, and gas sources for oxygen (O₂) and compressed air. Ventilators also require an integral or add-on-oxygen-air proportioner (blender) to deliver a fraction of inspired FiO₂ between 21 and 100%. Controls are used to determine the operating mode and ventilation variables. Most ventilators have several operating modes.

Principles of operation

Intensive care ventilators designed for neonatal and/or pediatric respiratory support are mostly time-cycled pressure-control devices. CPAP is useful for infants with restrictive lung disease or decreased lung compliance and alveolar collapse (infants with hyaline membrane disease); PEEP maintains lung volume and prevents alveolar collapse. High-frequency ventilation delivers small tidal volumes around a near-constant mean airway pressure (MAP) at frequencies higher than those produced during the fastest possible panting (i.e., above 100 breaths per minute), thus avoiding both high and low extremes of lung volume.

Operating steps

Users first check that the unit is ready for use (e.g., run performance and calibration checks). They next make sure that settings (including alarm levels) are correct and appropriate for the patient type and condition. Once completed, the patient is connected to the ventilator. When the ventilator-patient connection is completed, users ensure the patient is being properly ventilated. While patient is being ventilated, caregivers should monitor/evaluate the patient, and respond promptly to alarms.

Reported problems

Risk of acquiring pneumonia may be minimized by following proper infection control procedures. Leaks in the breathing circuit or components may prevent the ventilator from delivering the appropriate amount of ventilation. Proper maintenance and avoiding operator errors or machine failures can be critical. Critical changes in patient conditions can be missed if alarms are not set properly or are not noted by clinical staff.



Use and maintenance

User(s): Physicians, nurses, respiratory therapist, other medical staff

Maintenance: Biomedical or clinical engineer/technician, medical staff, manufacturer/servicer

Training: Initial training by manufacturer, operator's manuals, user's guide

Environment of use

Settings of use: Neonatal intensive care unit (NICU), pediatric intensive care unit (PICU), critical care settings, surgery

Requirements: Uninterruptible power source, battery backup, proper tubing/masks

Product specifications

Approx. dimensions (mm): 29 x 53 x 45

Approx. weight (kg): 27

Consumables: Batteries, tubing, masks, filters

Price range (USD): 7,500 - 45,000

Typical product life time (years): 8

Shelf life (consumables): NA

Types and variations

Cart or stand mounted



Ventilator, Portable

UMDNS

17423 Ventilators, Portable

GMDN

47083 Portable ventilator, electric

Other common names:

Continuous ventilators; home care ventilators; positive-pressure ventilators; time-cycled ventilators; Continuous, ventilator, home-use; Portable / home-use ventilator

Health problem addressed

Portable ventilators deliver room air or oxygen-enriched gas into the breathing circuit, where it can be humidified by a heated humidifier or a heat and moisture exchanger before delivery to the patient. They provide long-term support for patients who do not require complex critical care ventilators. They can be used for treating patients with conditions like pneumonia or during mass casualty events.

Product description

Ventilators designed to provide support to patients who do not require complex critical care ventilators. These ventilators typically consist of a flexible breathing circuit, a control system, monitors, and alarms. Some systems may also include specialized breathing circuits, oxygen accumulators, and heated humidifiers or heat and moisture exchangers (HMEs). Most devices use positive pressure to deliver gas to the lungs at normal breathing rates and tidal volumes through an endotracheal tube, a tracheostomy cannula, or a mask. Power is typically supplied from a power line or from an internal or external battery (e.g., a car battery). These ventilators are used for long-term respiratory support in extended care facilities and in the home; they may also be used in emergency care.

Principles of operation

Portable ventilators deliver room air or O₂-enriched gas into the breathing circuit, where it can be humidified by a heated humidifier or an HME before delivery to the patient. Typically, these ventilators drive air into the breathing circuit with a motor-driven piston or turbine. In the home setting, O₂ is usually delivered directly into the breathing circuit from a separate source, such as an O₂ tank. Most devices use positive pressure to deliver gas to the lungs at normal breathing rates and tidal volumes through an endotracheal tube, a tracheostomy cannula, or a mask. Portable/home care ventilators may use several methods of cycling (e.g., volume, time) and several ventilation modes, including control, assist/control, and synchronized intermittent mandatory ventilation (SIMV) modes.

Operating steps

Users first check that the unit is ready for use (e.g., run performance and calibration checks). They then make sure that settings (including alarms) are correct and appropriate for the patient type and condition. Once completed, the patient is connected to the ventilator. When the ventilator-patient connection is completed, users ensure that the patient is being properly ventilated. While patient is being ventilated, caregivers are responsible for monitoring/evaluating the patient, and for promptly responding to alarms.

Reported problems

Most of the reported problems involving portable ventilators arise from user error, poorly maintained exhalation valve assemblies, and the use of poor-quality breathing circuits. Other



issues include disconnection of the breathing circuit from the device, equipment failure, disconnection/kinking/bending of tubing, and extreme environmental conditions. Also, critical changes in patient conditions can be missed if alarms are not set properly or are not noted by clinical staff.

Use and maintenance

User(s): Physicians, nurses, respiratory therapist, other medical staff

Maintenance: Biomedical or clinical engineer/technician, medical staff, manufacturer/servicer

Training: Initial training by manufacturer, operator's manuals, user's guide; clinical staff to assist family with home care operation

Environment of use

Settings of use: Home care, long-term care facilities, patient transport vehicles

Requirements: Battery, uninterruptible power source (for recharging batteries), proper tubing/masks

Product specifications

Approx. dimensions (mm): 150 x 250 x 300

Approx. weight (kg): 7

Consumables: Batteries, tubing, masks, filters

Price range (USD): 3,300 - 13,500

Typical product life time (years): 8

Shelf life (consumables): Variable

Types and variations

Portable, carrying case



Videoconferencing system, Telemedicine

UMDNS

18138 Information Systems, Telemedicine, Videoconferencing

GMDN

36303 Video conferencing telemedicine system

Other common names:

Teleconferencing Systems, Video; Teleconsultation Systems; Telemedicine Videoconferencing Systems; Video Teleconferencing Systems; Videoconferencing Systems, Telemedicine

Health problem addressed

These systems are used for diagnosis and prescription of medical treatment for patients at remote locations, for remote clinical consultations between medical professionals, for education and training of medical staff, and for administrative/business functions. Telemedicine can be as simple as a telephone conversation between personnel or a fax transmission, or as complex as a real-time interactive video examination of a patient conducted by physicians separated by hundreds of miles.

Product description

Components of a telemedicine videoconferencing system vary, depending on the configuration chosen by the buyer. In general, system components include a codec, viewing monitor(s), camera(s), control/user interaction devices (e.g., mouse, keyboard,) input devices (e.g., document scanner, medical scopes), and output and storage devices (e.g., printers, CD-ROM drives). Most suppliers offer different configurations customized to the buyer's needs.

Principles of operation

Telemedicine videoconferencing uses video and telecommunications technology to transmit medical information (audio, video, and graphics) between two or more sites.

Operating steps

Patient examinations are conducted using instruments (e.g., stethoscopes, ophthalmoscopes) and examining cameras connected to the telemedicine system, allowing a physician at a remote site real-time access to the patient and real-time interaction with the examining physician, physician assistant, or nurse. A technician or nurse typically operates the instruments with the patient in an examination room. Images and data are then transmitted to the remote physician for viewing and analysis, and interacting with the patient.

Reported problems

The telemedicine system should have some form of security to avoid problems with data confidentiality. Electric fluctuations can damage computer components, impair system performance, disrupt program operation, and destroy data. Preventive measures include installing an online uninterruptible power supply. A dedicated power line isolated for the central processing unit may be useful to reduce signal noise. Copying disks at regular intervals protects stored information.



Use and maintenance

User(s): Physicians, medical professionals, administrators, students

Maintenance: Technicians; IT staff; biomedical or clinical engineer

Training: Initial training by manufacturer and manuals

Environment of use

Settings of use: Hospitals; private practices; clinics; schools

Requirements: Stable power source

Product specifications

Approx. dimensions (mm): NA

Approx. weight (kg): NA

Consumables: NA

Price range (USD): 1,495 - 177,000

Typical product life time (years): 5 to 7

Shelf life (consumables): NA

Types and variations

Mobile (rollabout); group (room); desktop



Warming Unit, Radiant, Infant

UMDNS

17956 Warming Units, Patient, Radiant, Infant
17433 Warming Units, Patient, Radiant, Infant, Mobile
12113 Incubators, Infant

GMDN

36812 Infant/regional-body warmer
17433 Infant warmer

Other common names:

Beds, Infant; Combination Incubator/Warmers; Infant Warmers; Mobile Warmers; Transport Warmers; Transport Radiant Warmers; Warmers, Infant, Radiant, Stationary

Health problem addressed _____

These devices are commonly used to provide thermal support for newborns in the delivery suite, for critically ill infants who require constant nursing intervention, and for infants undergoing treatment that prolongs exposure to a cool environment. Prolonged cold stress can overwork heat-producing mechanisms, drain energy reserves, and result in hypoxia, acidosis, hypoglycemia, and, in severe cases, death.

Product description _____

Infant radiant warmers are overhead heating units. They typically consist of a heat source, a skin-temperature sensor, an automatic (servo) control unit, and visual and audible alarms.

Principles of operation _____

A heating element generates a significant amount of radiant energy in the far IR wavelength region (longer than three microns to avoid damaging the infant's retina and cornea). The radiant output of the heating unit is also limited to prevent thermal damage to the infant. The IR energy is readily absorbed by the infant's skin; increased blood flow in the skin then transfers heat to the rest of the body by blood convection (heat exchange between the blood and tissue surfaces) and tissue conduction (heat transfer between adjacent tissue surfaces).

Operating steps _____

After birth, infants are placed under a radiant warmer until they can achieve thermoregulation.

Reported problems _____

Because warming by IR energy is an efficient means of energy transfer, extreme hyperthermia, skin burns, permanent brain damage, or even death can result.



Use and maintenance _____

User(s): Nursing staff; physicians

Maintenance: Medical staff; technician; biomedical or clinical engineer

Training: Initial training by manufacturer and manuals

Environment of use _____

Settings of use: Hospital; birthing center

Requirements: Stable power source

Product specifications _____

Approx. dimensions (mm): 2100x1310x750

Approx. weight (kg): 110

Consumables: NA

Price range (USD): 3,250 - 26,000

Typical product life time (years): 8

Shelf life (consumables): NA

Types and variations _____

Freestanding; modular; permanently-mounted

Whole Blood Coagulation Analyzer

UMDNS

16749 Analyzers, Point-of-Care, Whole Blood, Coagulation

GMDN

56689 Laboratory coagulation analyser IVD, automated

Other common names:

Thromboelastograph, thrombometer; Analyser, laboratory, haematology, coagulation, automated

Health problem addressed

Devices that measure the clotting mechanisms of hemostasis; used primarily to detect clotting deficiencies related to thromboembolytic disease, thrombocytopenia, impaired liver function, hemophilia, von Willebrand disease, and other conditions. They are also used to monitor the effect of drugs such as heparin, oral anticoagulants, and thrombolytic and antiplatelet agents on whole blood, as well as the effects of blood component therapy.

Product description

Handheld device or benchtop device, sometimes placed on a cart, with a display (usually LCD), a keypad to enter information, and a slot to insert a test strip or sample tube. Some models may have alarms, memory functions, touchpens, USB ports to transfer data to a computer, and/or a small storage compartment for reagents.

Principles of operation

One of three methods may be used: Mechanical impedance uses blood viscosity changes to determine clotting time. Instruments using the photometric principle monitor changes in the specimen's optical density to detect the beginning of clot formation. The electromagnetic uses a magnet in the test tube aligned with a magnetic detector in the cuvette and remains locked in position with the detector while the test tube rotates. When a clot forms, it entangles the magnet, breaking the electromagnetic coupling and allowing the magnet to rotate with the tube, terminating the test.

Operating steps

Whole blood samples are placed in tubes, on reaction cuvettes, or on test strips, and loaded into the analyzer. The operator may select the tests being performed on the sample using a keypad or connected computer.

Reported problems

Operators should be aware of the risk of exposure to potentially infectious bloodborne pathogens during testing procedures and should use universal precautions, including wearing gloves, face shields or masks, and gowns.



Use and maintenance

User(s): Medical staff

Maintenance: Laboratory technician; biomedical or clinical engineer

Training: Initial training by manufacturer and manuals

Environment of use

Settings of use: Hospital, patient bedside, physician office, clinical laboratory, home

Requirements: Line power, biohazard disposal

Product specifications

Approx. dimensions (mm): 200 x 150 x 300

Approx. weight (kg): 1-10

Consumables: Reagents (cartridges, test strips, etc.), reaction cuvettes

Price range (USD): 648 - 46,000

Typical product life time (years): 5-8

Shelf life (consumables): Reagents: 2 years

Types and variations

Handheld, portable, benchtop; some models may also test platelet function



Core Medical Equipment

